

Plate I
Henry A. House's Calculating Device.
 PATENTED NOV 29 1870

109619

Fig. 2

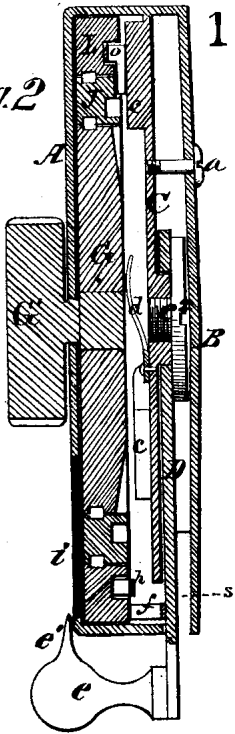

Fig. 1

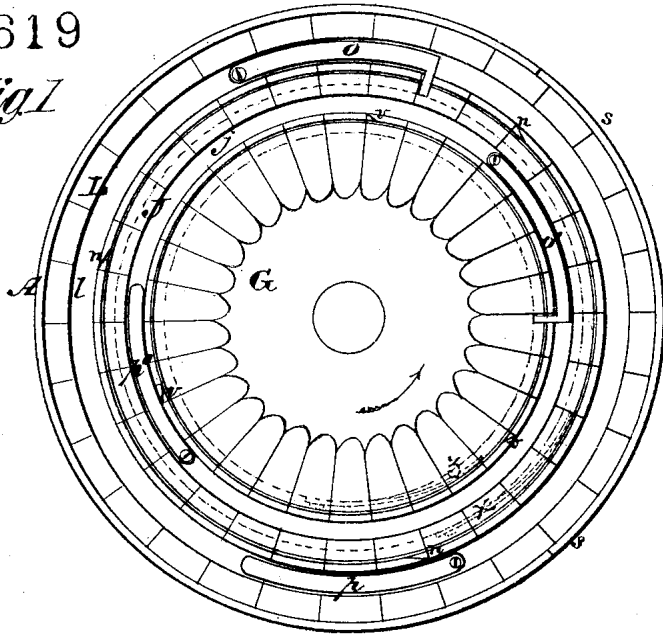

Fig. 4

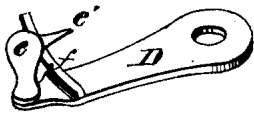
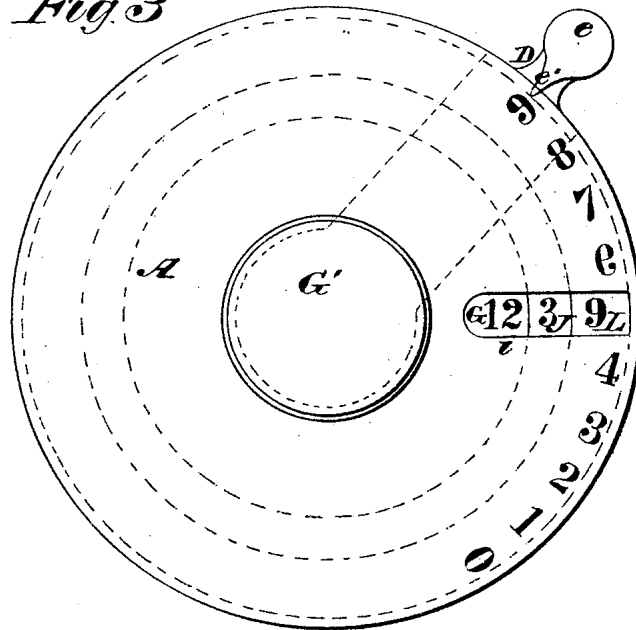

Fig. 3



Witnesses:
R. T. Campbell
J. N. Campbell

Inventor
Henry A. House
 by
Mason, Fenwick & Lawrence.

Plate 2
Henry A. House's Calculating Device

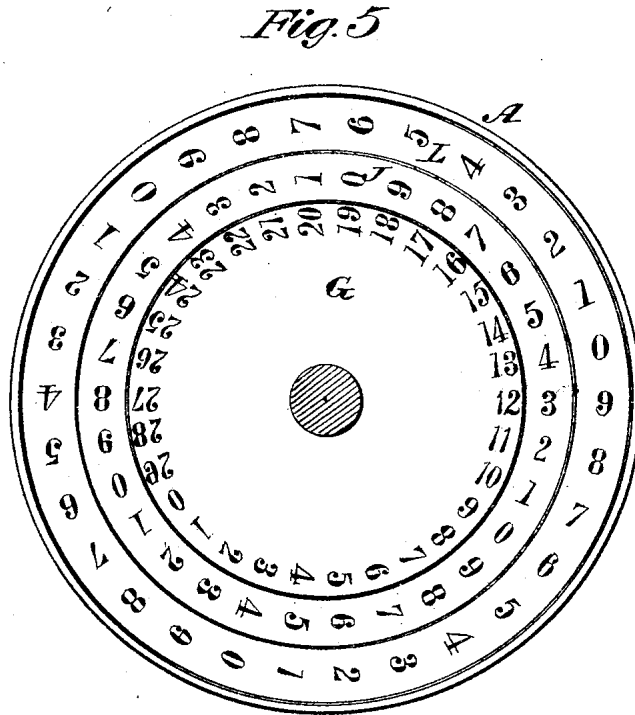
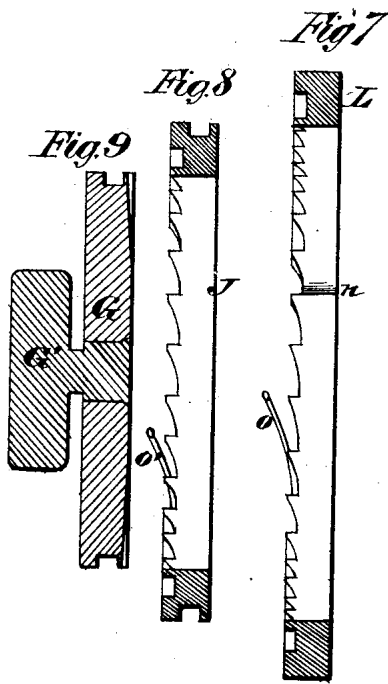
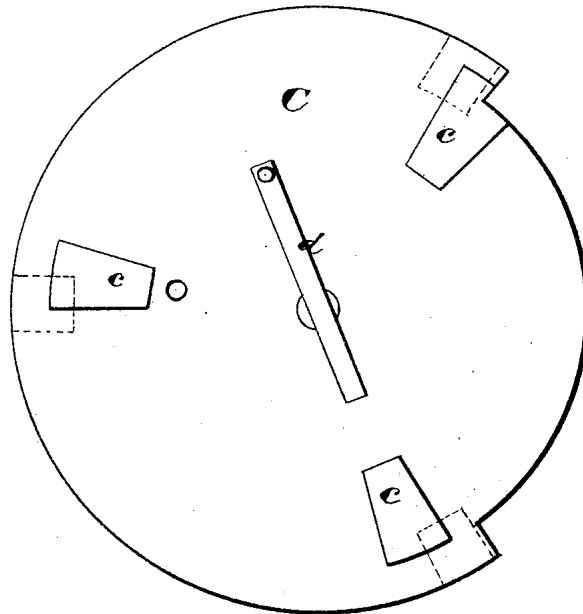
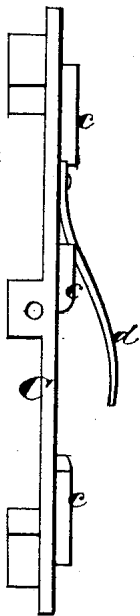

Fig. 10

Fig. 6



Witnesses.
R. J. Campbell.
Geo. Campbell.

Inventor
Henry A. House
by
Mason, Newick & Lawrence.

United States Patent Office.

HENRY A. HOUSE, OF BRIDGEPORT, CONNECTICUT.

Letters Patent No. 109,619, dated November 29, 1870.

IMPROVEMENT IN ADDING AND SUBTRACTING-REGISTERS.

The Schedule referred to in these Letters Patent and making part of the same.

To all whom it may concern:

Be it known that I, HENRY A. HOUSE, of Bridgeport, in the county of Fairfield and State of Connecticut, have invented a new and improved Calculating Device; and I do hereby declare that the following is a full, clear, and exact description thereof, reference being had to the accompanying drawing making part of this specification, in which—

Figure 1, plate 1, is a view of the toothed disk and toothed rings, as seen by removing the back of the case and the inside cam-disk.

Figure 2, plate 1, is a diametrical section through the device.

Figure 3, plate 1, is a front view of the device complete.

Figure 4, plate 1, is a perspective view of the vibrating arm and its pawl.

Figure 5, plate 2, is a view of the front sides of the toothed disk and its toothed rings, showing the manner of arranging numbers thereon.

Figure 6, plate 2, is a view of the cam-face of the cam-disk.

Figures 7 and 8, plate 2, are diametrical sections through the toothed rings.

Figure 9, plate 2, is a diametrical section through the setting-wheel.

Figure 10, plate 2, is an edge view of the cam-plate.

Similar letters of reference indicate corresponding parts in the several figures.

The object of my invention is to improve portable or pocket calculating-machines, so that they can be more easily manipulated, and at the same time made very simple, accurate, and complete.

The improvement which I have made on the pocket register or calculator, which is composed of a series of concentric rings, numbered with decims running in regular order from 0 to 9, consists in combining with the mechanism which will move the rings forward, a mechanism which will move them back again for commencing the calculation with any given number or figure.

The following description will enable others skilled in the art to understand my invention.

The case which contains the toothed wheels, their cams and pawls, consists of two parts, A and B.

The part A has a radial slot, *i*, through it, for exposing to view the numbers which are marked on the upper sides of the wheel G and concentric rings L J, as these numbers are successively moved opposite this opening.

A long slot, *s*, is also made through the rim of the part A, for a pawl-arm, D, to vibrate.

Within this case a wheel, G, is centrally applied and fastened to the stem of a knob, G', by means of which this wheel can be turned freely, and between the wheel G and the rim of the case are two concen-

tric rings, L J, which can be turned about the axis of the wheel G, as will be hereinafter explained.

The wheel G has teeth made radially on its back side extending out to its periphery, and to the latter a spring pawl, *Z*, (see fig. 1,) is fastened, which, when wheel G is turned in one direction, will engage with one or the other of the notches *v* made into the inner edge or ring J, and cause this ring to move around with it.

A similar pawl, *x*, (see fig. 1,) is applied to the periphery of the ring J, which, when this ring is turned as above stated, will engage with one or the other of the notches *n* made into the inner edge of the ring L, and cause this ring to move around with the wheel G and ring J.

On the front side of each one of the rings L J are three decims, each decim running in regular numerical order from 0 to 9, and on the front side of the wheel G numbers are made, running in a concentric circle, from 0 to 29.

There are thirty characters on each one of the rings, and a corresponding number on the wheel G, so arranged that, when all the numbers on the rings representing the same value are opposite each other, these rings will be engaged with each other by the pawl *x*, and when the cipher on the wheel G is opposite either one of the corresponding marks on the ring J, the pawl *x* will engage the latter with the former; consequently, by turning the wheel G in the direction indicated by the arrow in fig. 1, three ciphers can be brought in line with each other opposite the opening *i*, through the front of the case.

There are thirty ratchet-teeth on the back of each one of the rings L J, so spaced that, when the rings are adjusted, as shown in fig. 1, their teeth will be in lines coinciding with the teeth on the back of wheel G.

The teeth on the ring L are acted upon by a spring-pawl, *f*, on a vibrating arm, D.

The teeth on the ring J are acted upon by a hooked spring-pawl, *o*, and the teeth on wheel G are acted on by a hooked spring-pawl, *o'*.

The springs *p p*, which are applied in grooves in the rings, press against a disk, C, and keep the rings in close contact with the front plate of the case.

The pawl-arm D vibrates freely about a short hub, which is centrally formed on the back of the disk C, and on the exposed end of this arm a knob, *e*, is secured, having a pointer, *e'*, formed on it, which latter is directed toward the center of the case and is intended to point at figures which are marked on the front of the case on opposite sides of the slot *i*, as shown in fig. 3. These figures run from 0 to 9.

By vibrating the arm D the ring L is moved by pawl *f* engaging with the teeth on this ring.

The ring J is moved a distance equal to the spaces between its numbers or characters, by means of the hooked-pawl *o*, which, at certain times, is pressed up-

on by one of three cams, *c*, on the face of disk *C*; and the wheel *G* is in like manner moved by the pawl *o'*, as the latter passes by one of said cams *c*.

The arm *D* is connected to the hub of the disk *C* by means of a screw, *e'*.

The disk *C* is secured fast to the rim of the case, and the back plate *B* of the case is secured to the disk in any suitable manner.

Screw *a* may be used to secure the back *B* to the case.

Before using the instrument to calculate, the knob *G'* is turned until the ciphers on the wheel *G*, the ring *J*, and ring *L* are brought in line opposite the slot *i*. The instrument is then held in the left hand; with the fingers of the left hand or right hand the arm *D* is vibrated, and its pointer *e'* moved opposite the required number marked on the face of the case, each time moving the arm back as far as it will go.

The first ring *L* will indicate tens, and the third wheel indicates hundreds and thousands.

By means of the wheel *G*, and its external knob *G'*, the rings can be quickly turned back to the ciphers, or to any required numbers.

Having described my invention,

What I claim as new, and desire to secure by Letters Patent, is—

1. The combination, with one or more concentric rings, which are numbered, toothed, and notched, and are interlocked periodically with each other in their forward movement, of the toothed setting-wheel *G*, and pawl *Z*, or pawls *z* and *x*, for reversing the movement of the rings, substantially as described.

2. The combination of the cams *c*, fixed disk *C*, hooked spring-pawl *o'*, toothed rings *J* *L*, set-wheel *G*, and spring-pawl *Z*, or pawls *z* *x*, substantially as described.

HENRY A. HOUSE.

Witnesses:

GEORGE C. BISHOP,
JOHN H. VINTON.