

T. HILL.  
ARITHMOMETER.

No. 18,692.

Patented Nov. 24, 1857.

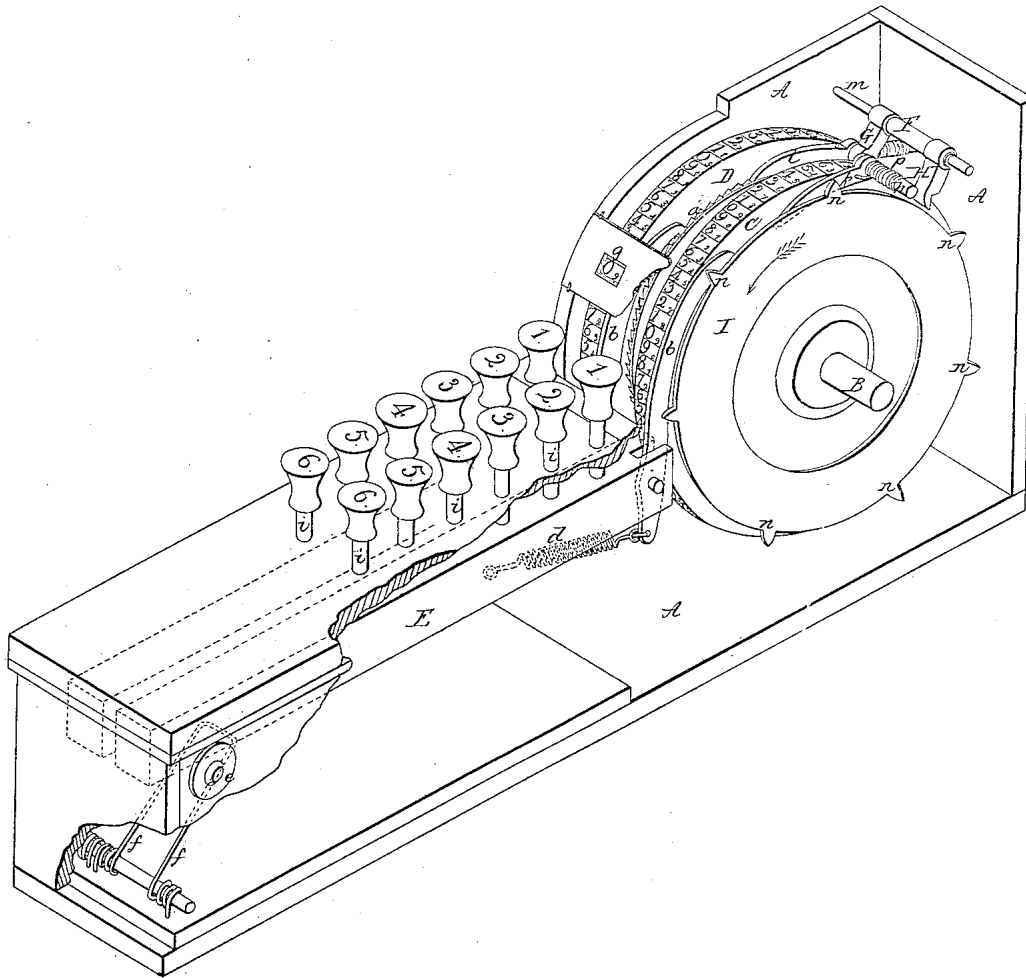

# UNITED STATES PATENT OFFICE.

THOMAS HILL, OF WALTHAM, MASSACHUSETTS.

## IMPROVED ARITHMOMETER.

Specification forming part of Letters Patent No. 18,692, dated November 24, 1857.

### *To all whom it may concern:*

Be it known that I, THOMAS HILL, of Waltham, in the county of Middlesex and State of Massachusetts, have invented a new and useful Mechanical Calculator for the Purpose of Performing Various Mathematical Calculations, of which the following is a full, clear, and exact description, reference being had to the accompanying drawing, making part of this specification, in which the figure is a perspective view of my machine, part of the case being removed to show the mechanism within.

I will first explain the mechanical construction of the calculator, and then describe its operation.

In the drawing, A is the case or frame of the machine, in suitable bearings in the sides of which is hung the shaft B, which carries the count-wheels C and D, of which there may be any required number, the wheel C representing units and the wheel D tens, and so on. These wheels are constructed and arranged in the following manner: Each wheel has marked on its periphery at equal distances apart in the row the figures 1 2 3 4 5 6 7 8 9 0, repeated as often as the size of the wheel and the distance of the figures will allow. Alongside this first row is placed a second one of the same series of figures, but with their position reversed with regard to the first ones, so that figure 9 of one row comes opposite 0 of the other. That they may be more readily distinguished, the figures of one row are made larger than those of the other. The larger figures are used for addition and multiplication, the smaller ones for subtraction and division. Each wheel has attached to its side a ratchet *a*, which is operated by a feed-pawl *b*, attached to the end of a lever E, placed opposite to the face of the wheel and at right angles to the axle B. The pawl *b* is pivoted to the end of the lever at *c*, and is held in contact with the ratchet by a spring *d*. The other end of the lever E is pivoted to the frame at *e*, and is held up in position by a spring *f* beneath it. Through the top or lid of the case over each lever E project the pins or keys *i*, which are arranged in a row along the lever E. They are numbered from 1 to 0, (in the drawing but six are shown,) and as they are nearly of uniform length their position over the lever or the place on its length on which

each pin strikes will regulate the amount of the depression of the outer end of the lever to which the pawl *b* is attached—that is, when the key marked 1 is depressed the lever E will be vibrated sufficiently far for the pawl *d* to feed forward the wheel to which this lever belongs one notch or number. (The number of notches correspond with the number of figures on the wheel.) When the key 6 is depressed, it being nearer the point at which the lever is pivoted will vibrate it a greater distance, and the pawl *b* will feed forward the wheel the distance of six numbers.

There is a lever E and a row of keys *i* for each count-wheel used. The count-wheels are arranged with a double row of figures in the manner described to save employing a greater number of wheels, as the same wheel serves both for addition and subtraction by using the different rows of figures.

A card is attached to the front of the case A through suitable holes *g*, in which the numbers on the wheels may be read.

A pin *h* is secured to one side of the case. Around this is wound a spring, which holds a retaining-pawl *k* in contact with the ratchet of the wheel C. A similar pawl *l* drops into the notches of the ratchet *a* of the wheel D. This pawl serves also to feed forward the wheel D at intervals, as will be more fully explained. A light shaft *m*, supported in the sides of the case, carries a sleeve F, which turns freely upon it. To this sleeve is attached an arm G, to the outer end of which is pivoted the pawl *l*, and an arm H, which is vibrated at intervals by the revolution of the wheel C in the following manner: On the side of the wheel C, alongside of its ratchet *a*, is attached a wheel I, having teeth *n* at such intervals that when the wheel C has revolved a distance equal to the space occupied by ten figures on its rim one of the teeth *n* shall strike the arm H and vibrate it and the arm G, which movement thrusts forward the pawl *l* and moves the wheel D one notch. When more wheels are employed, this arrangement will be continued on, so that the wheel D moving the space of ten figures shall operate the succeeding wheel one notch, and so on. A spiral spring *p* is fastened to the case and to the pawl *l*. It serves to hold the pawl in contact with the ratchet, and also to

draw back the arm G when the arm H escapes from the tooth *n*.

Operation: The larger characters are to be used for addition and multiplication and the smaller ones for subtraction and division. The process of addition is as follows: The wheels being each arranged with the character 0 opposite the openings *g*, the key *i*, which corresponds to the first figure of the column to be added, is depressed, then that one corresponding to the next figure, and so on through the column, using the first row of keys or those belonging to wheel C when adding a single column or one in the units place. Each time a key is depressed the wheel C will be fed forward, in the manner before explained, a distance corresponding to the number of the key depressed, and each time ten is counted on this wheel a tooth *n* on the wheel I will vibrate the arms H and G, and the wheel D will be fed forward one number, counting ten, and by a similar arrangement when this wheel has moved a space of ten figures it will operate the succeeding wheel of the series and count one on it or one hundred. (Only two wheels are shown on the drawing; but the number may be increased according to the requirements of the machine.) If several columns of figures are to be added, it is immaterial whether the figures are read from bottom to top or from side to side. The result will be the same if the row of keys corresponding to the place of the figures, whether in the units, tens, or hundreds column, is used.

For subtraction, as before stated, the circle of smaller figures only is used. The wheels are placed in position to read the greater amount off through the openings *g* in the card. The figures composing the smaller amount or that to be subtracted are noted or struck upon the keys, as in the previous operation, when the result can be read off from the wheels.

For multiplication the circle of larger figures is used, starting at 0. The keys corresponding to the figures in the multiplicand are depressed as many times as will make up

the sum of the multiplier. Thus if five is to be multiplied by three the key 5 is depressed three times, when the sum will show through the card—viz., 1 on the wheel D and 5 on the wheel C—and in the same manner for higher numbers where more wheels are used.

For division use the smaller figures. Arrange the wheels so that the dividend will be opposite the openings in the card, then depress the key or keys corresponding to the divisor as many times as is requisite to bring up a number less than the divisor. This number will be the remainder, and the number of times the key has been depressed will be the quotient. Thus if eight is divided by three the small figure 8 is brought opposite the opening *g* and the key 3 is depressed, when the figure 5 will appear. As this is greater than three, the key must be again depressed, when 2 will appear. This is the remainder, and as the key has been depressed twice two will be the quotient.

With the above-described machine the operator can by mere mechanical operation of pressing the keys corresponding to the figures employed perform the most laborious computations with dispatch and certainty.

What I claim as my invention, and desire to secure by Letters Patent, is—

1. The use in a mechanical calculator of the series of wheels C D, &c., having each a double row of characters, arranged in the manner and for the purpose, substantially as set forth.

2. Operating the said wheels by the keys *i*, the levers E, and pawls *b*, or their substantial equivalents, in the manner herein described.

3. The wheel I, in combination with the arms H and G and pawl *l*, constructed and operating substantially as described, for the purpose specified.

THOMAS HILL.

Witnesses:

R. MERRIS COPELAND,  
ANNE F. HILL.