

M. M. CRAM.
 ADDING-MACHINES.

No. 193,853.

Patented Aug. 7, 1877.

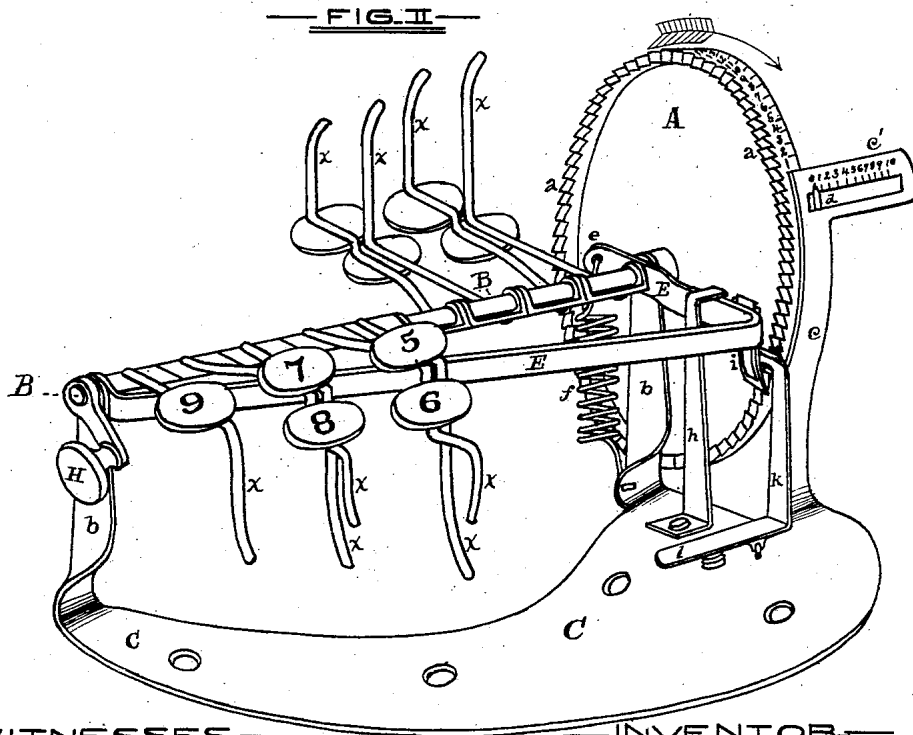
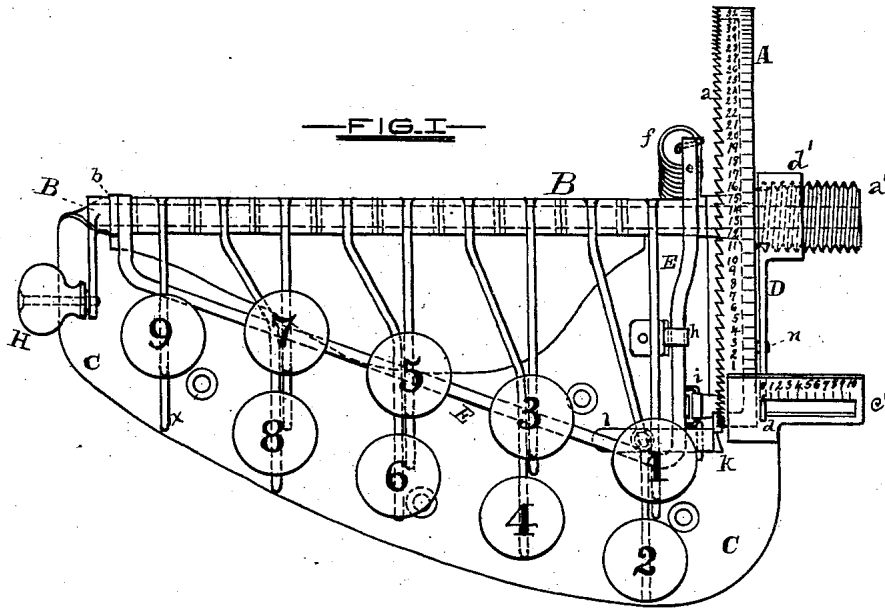

—WITNESSES—

—INVENTOR—

Mrs. B. Mann

M. M. Cram

Edwin Blackburn

By *Chas B. Mann, Attorney*

UNITED STATES PATENT OFFICE.

MARSHALL M. CRAM, OF MANKATO, MINNESOTA.

IMPROVEMENT IN ADDING-MACHINES.

Specification forming part of Letters Patent No. **193,853**, dated August 7, 1877; application filed April 19, 1877.

To all whom it may concern:

Be it known that I, MARSHALL M. CRAM, of Mankato, in the county of Blue Earth and State of Minnesota, have invented a new and useful Improvement in Adding-Machines, of which the following is a specification:

In the accompanying drawings, Figure 1 is a plan view; and Fig. 2 is a perspective view, part of the digit-keys being removed.

A represents a flanged ratchet-wheel, on the flange of which are one hundred teeth, *a*. The hub *a'* extends on one side, and is screw-threaded on the exterior. The wheel is secured to the shaft B, which is supported by two standards, *b b*, cut, with the base-plate C, from one piece of sheet metal, and bent up, and a quarter-twist given, as shown. The standard *c*, with slotted indicator-scale *c'*, is also of the same piece as the base-plate. The arm D has a screw-threaded socket, *d'*, and screws on the hub of the wheel. The pointer or index *d*, carried by the arm, moves in the slotted indicator-scale. The periphery of the wheel A is divided into spaces indicating units and tens, and numbered corresponding to the one hundred teeth.

E is a yoke, through both ends of which the shaft B passes, and the yoke has swinging play up and down, the ends being between the supports *b*. One end of the yoke is extended beyond the shaft, as shown at *e*, and has attached a spiral spring, *f*, the other end of which is fastened to the base-plate. The upright *h* is secured to the base-plate, and has the top end bent over to serve as a stop for the yoke, the latter being held up to the stop by the spring *f*, acting on the extended end *e*. The yoke carries a ratchet-pawl, *i*, in such position as to engage the teeth on the wheel. *k* is a rectangular lever, pivoted to the base-plate, and has under the part *l* a spring, which keeps the catch on the upper end of lever engaged with the teeth of the wheel. This catch also forms a lug, which serves to release the pawl *i* when the part *l* of the lever, immediately below the number-one key, is depressed.

The numbers 1, 2, 3, 4, 5, 6, 7, 8, and 9 are digit-keys, each of which is pivoted or swung on the shaft, and, resting in front on the yoke E, have stop ends *x x x* bent down-

ward, the stop of each key being of such length that when a key is pressed down until the stop end strikes the base-plate the wheel turns forward in the direction of the arrow a number of units corresponding to the number of the key.

H represents a crank, which, when the pawl and lever-catch are disengaged, is used for the purpose of turning the wheel back until the pin *n* on the wheel strikes against the pointer-arm D, by reason of the latter moving inward by the reverse rotation of the screw-threaded hub. The base-plate C is secured to a board, or may be fastened to a table.

My adding-machine operates in the following manner: The figures on the slotted indicator-scale *c'* indicate hundreds, and those on the periphery of the wheel just above the indicator are units. The operator works the keys with his right hand, the thumb being used on key No. 9. To add a column of figures, a key corresponding to each figure is pressed down as far as it will go, and allowed to rise again before pressing another. After pressing keys to correspond with all the numbers, the sum is read off from the indicator, as shown by the pointer *d*, and from the wheel just above the indicator. If another column is to be added, set down the right-hand figure, the others being "to carry;" then, pressing the lever *l*, turn back the wheel by means of the crank H, as far as it will go, when the pointer will be at 0 on the indicator, and 0 0 will show on the wheel. Then count first what there was to carry, and proceed with the next column.

Having described my invention, I claim and desire to secure by Letters Patent—

1. The flanged ratchet-wheel A, having on its periphery numbered spaces indicating units and tens, with the hub *a'* extended on one side and screw-threaded exteriorly, the arm D, with screw-threaded socket *d'*, and carrying the pointer *d*, substantially as shown.

2. The base-plate C, standards *b*, and standard *c*, with indicator-scale *c'*, all cut from one piece of sheet metal.

3. The pawl *i*, attached to the yoke E, rectangular lever *k*, pivoted to the base-plate, and having a spring under the part *l*, and a

catch on the upper end of the lever, and also a side lug engaging with the pawl *i*, as shown and described, and for the purpose specified.

4. The standards *b*, supporting the shaft B, the yoke E, having the extended end *e* connected to a spring, for the purpose specified, in combination with stop *h* and the nine digit-keys, pivoted or swung to the shaft, and resting in front on the yoke, the keys having

downward-extending stop ends of variable length, the said parts operating in connection with the ratchet-wheel A, as shown and described.

M. M. CRAM.

Witnesses:

H. K. LEE,

HENRY TOURTELOTTE.