

(Model.)

3 Sheets—Sheet 1.

M. BOUCHET.  
ADDING MACHINE.

No. 251,823.

Patented Jan. 3, 1882.

*Fig. 1.*

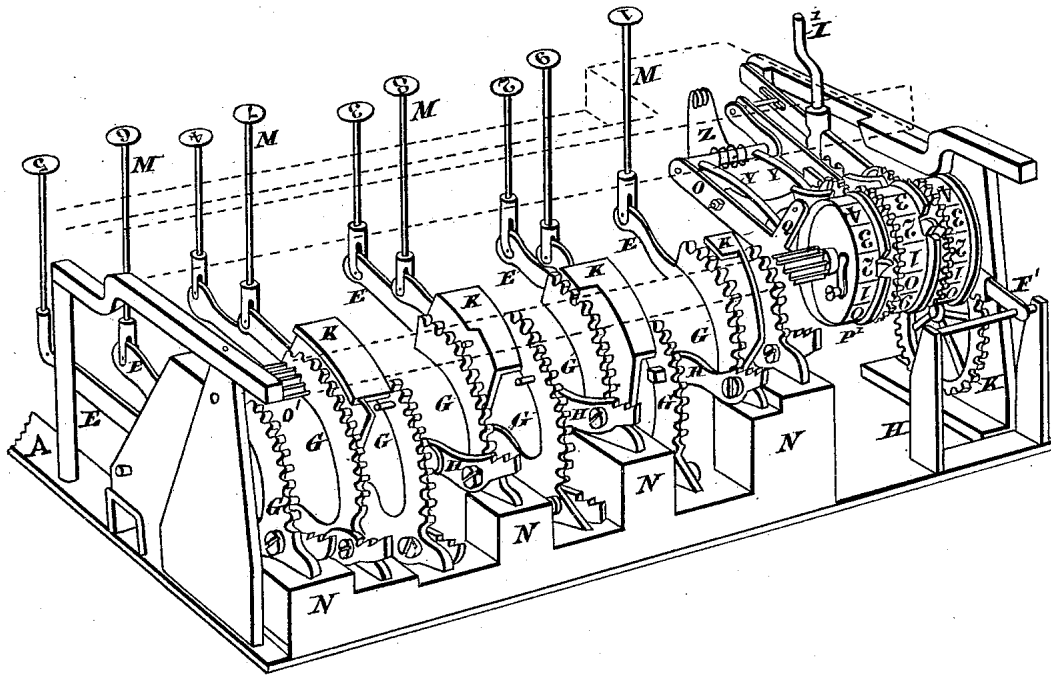

WITNESSES.

*Frank Pardon*  
*C. Hewitt*

INVENTOR.

*Michael Bouchet*  
*by J. G. Hewitt*  
*Attorney*

M. BOUCHET.  
ADDING MACHINE.

No. 251.823.

Patented Jan. 3, 1882.

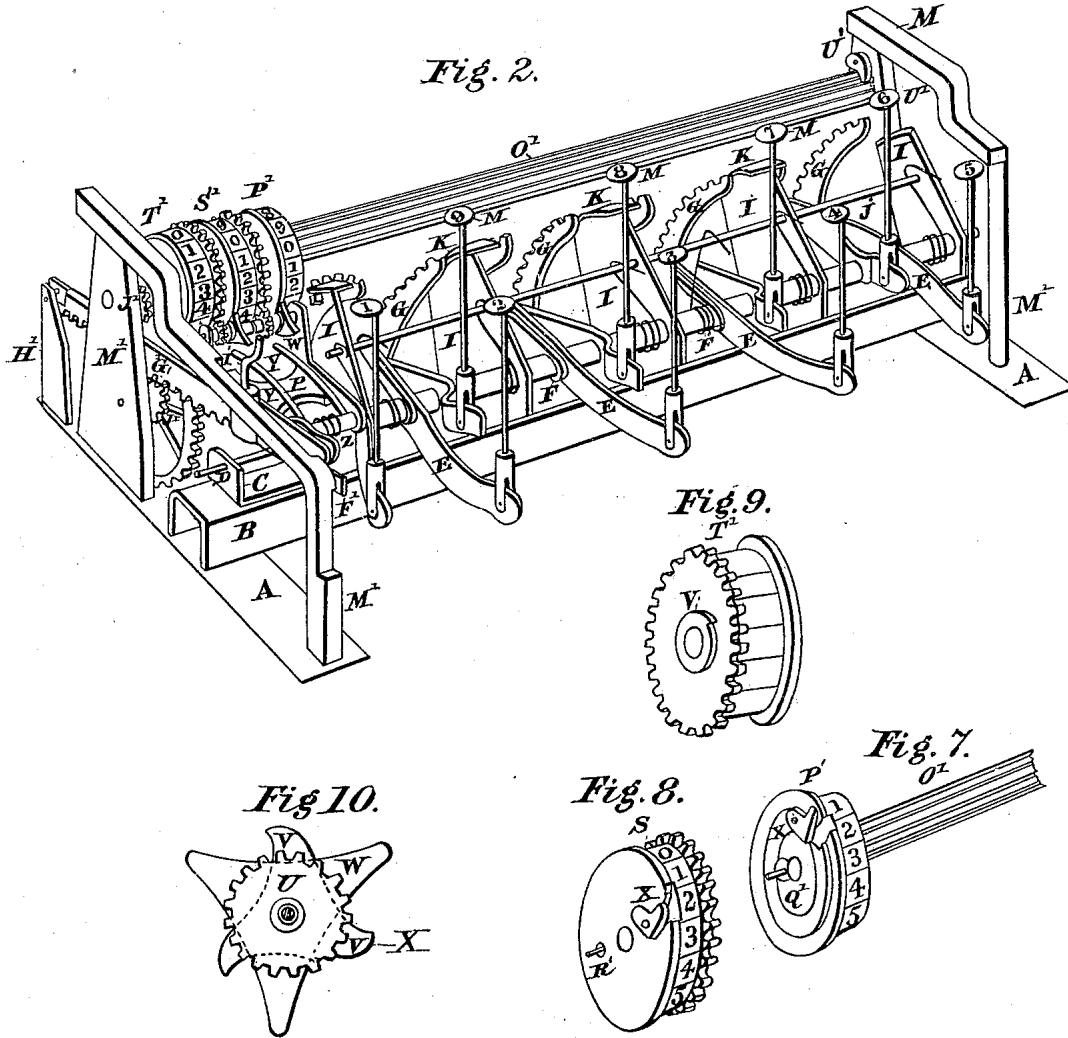

WITNESSES.

Frank Pardon  
C. Hewitt

INVENTOR.

Michael Bouchet  
by J. S. Hewitt  
Attorney

M. BOUCHET.  
ADDING MACHINE.

No. 251,823.

Patented Jan. 3, 1882.

Fig. 3.

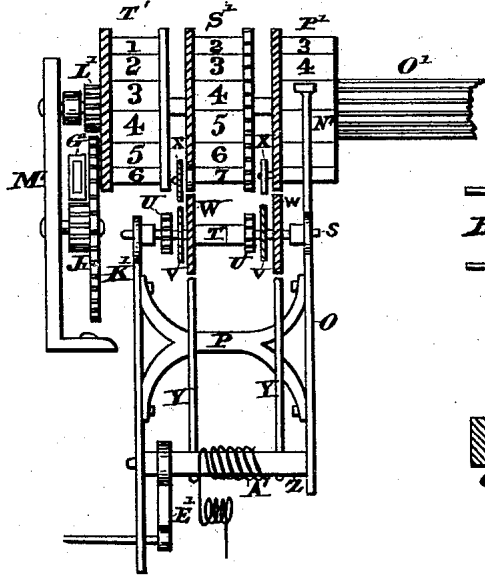

Fig. 4.

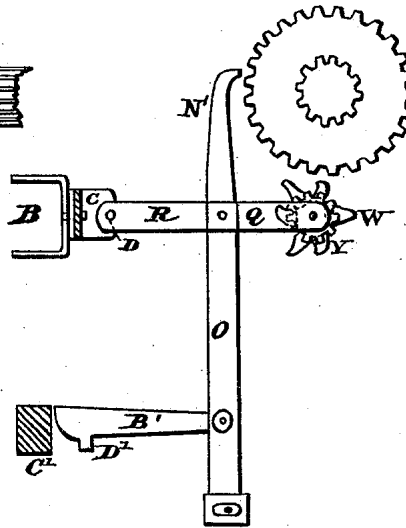

Fig. 5.

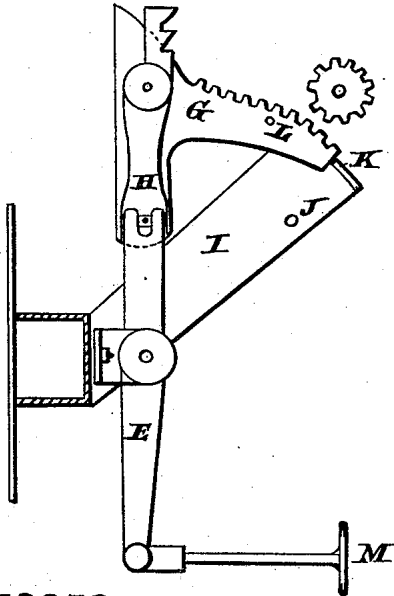
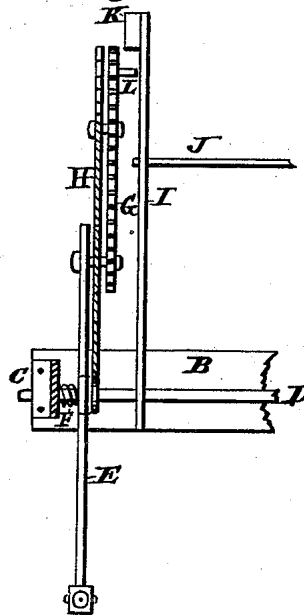

Fig. 6.



WITNESSES.

*Frank Pardon*  
*C. Hewitt*

INVENTOR.

*Michael Bouchet*  
*by J. S. Hewitt*  
*attorney*

# UNITED STATES PATENT OFFICE.

MICHAEL BOUCHET, OF LOUISVILLE, KENTUCKY, ASSIGNOR OF ONE-HALF  
TO BENNETT D. MATTINGLY, OF SAME PLACE.

## ADDING-MACHINE.

SPECIFICATION forming part of Letters Patent No. 251,823, dated January 3, 1882.

Application filed March 31, 1881. (Model.)

*To all whom it may concern:*

Be it known that I, MICHAEL BOUCHET, of the city of Louisville, in the county of Jefferson and State of Kentucky, have invented a certain new and useful Improvement in Machines for Adding Figures; and I do hereby declare that the following is a full, clear, and exact description of the construction and operation of the same, reference being had to the accompanying drawings, forming part of this specification.

This my invention relates to a certain new and useful improvement in adding-machines, consisting, first, in a small frame of suitable size with a cog-roller working on bearings near the top of the frame, extending about three-fourths of the entire length of the frame, the remainder being made up by a stationary stud-pin secured in the frame, the end of which is made to answer as a journal-bearing for the first-named roller, which, when operated, is held in position at each movement by a pawl secured to the frame at the end. This last-named cog-roller is provided with a small indicator-pulley on the end next to the stud-pin, with a flange on the left side, and a face wide enough to receive a series of figures from 1 to 10. In connection with this last-named pulley, two others of similar dimensions, with flanges on the side and figures on the face, are made to work loosely on the stud-pin at the end of the roller, which roller and pulleys are operated by a series of cog-segments (nine in number) hinged to the ends of small levers which work loosely on a stationary rod near the base of the frame, each of which is provided with a spiral spring around the rod connecting with the levers, for the purpose of replacing them after being pressed down in its operation, which is done somewhat similar to that of an ordinary piano, the end of the levers being provided with connections, to which a set of vertical pins are hinged, the upper ends of which are each provided with a small button-shaped knob, with figures running up from 1 to 9, in addition to the cipher, and by pressing down any one of these knobs, which represent the figures in the column of the book, said figure will be turned up and shown on the first pulley, which represents units up to 10, and when above that number the next pulley, which represents tens, will be turned to indi-

cate the number of tens, and when above tens the third pulley, which represents hundreds, will be turned by the second to indicate the number of hundreds, and so on in like manner to any number of thousands. The cog-segments which operate the roller and first pulley are each provided with the required number of cogs to turn up the figure on the pulley indicated by the knob pressed down. The second and third pulleys are operated by the first by means of a trigger on the inside face, which catches a three-pointed device secured to the pinion which operates the second pulley, and thereby turns it one figure at a time with each revolution of the first pulley until a full revolution of the second is made, when the trigger on it catches a similar three-pointed device and turns the third pulley one figure at a time with each revolution of the second, thereby indicating hundreds, and when thus operated each pulley is held in position by means of another somewhat similar three-pointed device, which works against the flange of the pulleys for that purpose. These last-named pinions and three-pointed devices, by which the second and third pulleys are operated, are secured firmly together and made to work loosely on a small rod passing through the upper ends of vertical arms extending up from the prongs of a bifurcated lever hinged to the lever-rod below by means of arms extending down from the prongs, and is further provided with a spiral spring in front to replace it after being pressed down to ungear the pinions and set the pulleys, which always remain in gear; but when necessary to set them preparatory to commencing operations the right-hand part of this last-named lever extends down under the first pulley, with a catch on the end to hold it when set. The front of the parts has a small shaft working loosely in bearings, with two pins extending in under the three-pointed devices that hold the pulleys, and are pressed up by a spiral spring on the shaft. This shaft is further provided with an arm extending down and resting on a small block on the frame, to answer as a stand for holding up the lever; but when necessary to ungear the pinions it is tripped from the block and made to rest on a small projection on the edge. The upper end of this arm stands at an angle, and has a pin

in the end sufficiently long to extend through a vertical slot in the operating-lever O, and connects with the bar of the rack, which operates the wheels in setting the pulleys preparatory to commencing operation, which is done by simply drawing back the rack and pressing it down until it engages with the pinion, and by pressing it in the pulleys will be turned.

The object of this my invention is to provide a machine for adding figures that will be cheap, durable, reliable, and not likely to get out of order, and by means of which much valuable time and labor are saved, thereby greatly assisting book-keepers and others in adding up their accounts, all of which I attain by the mechanism illustrated in the drawings, in which—

Figure 1 is a perspective view of the machine, showing its general construction. Fig. 2 is a perspective view of the machine, taken from the back, with the cover removed to show the interior arrangement of the several parts. Fig. 3 is a top view of the double operating-lever, showing the indicator-pulleys and other machinery connected therewith. Fig. 4 is a side elevation of the double lever, showing the stand and other devices connected with it. Fig. 5 is a side elevation of one of the single operating-levers, showing the cog-segments and additional lever to which it is hinged, and also the plates which separate them. Fig. 6 is a top view of the operating-levers, showing the levers, cog-segments, and plates between them. Fig. 7 is a perspective view of one of the indicator-pulleys and part of the cog-roller, showing the trigger and pin on the side. Fig. 8 is a perspective view of an indicator-pulley, showing the pin and trigger on the side. Fig. 9 is a perspective view of an indicator-pulley, showing the clutch-pawl on the face. Fig. 10 is a flat view, showing the pinion and three-pointed devices that operate the pulleys.

Similar letters refer to similar parts throughout the several views.

This my invention will be more fully illustrated in detail in the drawings, in which—

A A represent the frame, which is made of metal and in form as shown in the drawings.

B is a raised base on the frame, to which the segments or operating-levers are hinged.

C is a stand on the base B, through which a rod, D, passes, and to which the operating-levers E E are hinged near their centers, and further provided with spiral springs F F around the rod D, connecting with the levers, for the purpose of replacing them after being pressed down in their operation. The ends of these levers E E, where they connect with the cog-segment lever, are each provided with a slit, as shown in Fig. 5, which works on a stationary-pin in the lower point of the cog-segments G, and also passes through a vertical slot in lever H, which is also hinged to the rod D at the side of lever E, and thereby gives motion to the segment G by the operation of the levers E. This last-named lever H has two teeth in the extreme end, to

answer as a catch or stop for the roller O' when turned by the segment G by pressing down lever E.

I I are thin pieces of metal secured to the base B between the levers E, and are held in place at the top by the rod J, which passes through them.

K is a flange on the metal pieces I, and L' are small pins on the side of the segments G, which passes up over the flanges K in rising, but drops under them in falling.

M M are the button-shaped knobs and stems by which the levers E are operated.

N N are blocks upon which the segments G rest when replaced.

O O is a double lever secured together in the center by a bifurcated brace, P, sufficiently wide apart to receive the pinions and three-pointed devices that operate the pulleys. These levers O O have each a vertical arm, Q, above and R below. By means of the latter they are hinged to the rod D on the base.

S is a pin through the ends of the arms Q, and T are sleeves on the same pin. U U are pinions on these sleeves, for operating the indicator-pulleys.

V V are three pointed devices, for giving motion to the pinions U when caught by the triggers X X on the first and second pulleys, and thereby transmitting motion to the third. W is another somewhat similar three-pointed device, which works on the flange of the pulleys to keep them from turning when set, but will turn in a recess in the flange at the trigger when the pinion is turned. These two three-pointed devices and the pinions that turn the pulleys are all secured firmly on the same sleeve, side by side.

Y Y are pins in the shaft Z, for pressing up against the three-pointed devices W to prevent the pinions U from turning when thrown out of gear in setting the machine, and are held in position by the spring A'.

B' is a stand for holding up the lever O to keep the pinions U in gear while in operation; but when necessary to set the pulleys ready for use the lower end of this stand is tripped off the block C', so as to rest on the projection D' until the pulleys are set, when it is raised and replaced on the block with the pinions in gear, ready for use. This stand B' is operated by means of the arm E', which has a pin in the end passing through a vertical slot in the end of lever O, and connects with the bar F', upon which the cog-rack G' is made to slide. This rack G' is intended for the purpose of setting the machine preparatory to commencing, the bar upon which it slides being hinged to the lever O at one end and to the stand H' at the other, so that when pressed down by the handle I' it gears into the pinion J' of wheel K', which works into the roller-pinion L', and thereby turns the pulleys to their proper places, after which the rack is raised or replaced by a spring, and the pulley is left free to operate upon. M' is the stand on which they work.

N' is an arm of lever O, extending down under the first pulleys, with a catch on the end for holding it in place when set.

O' is a fluted cog-roller extending about three-fourths of the length of the frame, one end of which works in a bearing in the frame, while the other works on a stationary stud-pin extending out from the frame.

P' is a pulley secured firmly on the end of the roller, and by means of which the others are operated, which is done by the triggers X X on the side after a full revolution has been made, when they will be turned by the pins Q' and R' acting against the catches V in the face. These pulleys P', S', and T' are all made in form as shown in the drawings, with letters on the face from 1 to 10, or to a cipher.

U' is a pawl on the frame, to hold the cog-roller O' when set.

The pinions U and three-pointed devices V and W, that operate the indicator-pulleys, may be made as above described, or, if necessary, may be dispensed with entirely; and two separate pinions of double length, with a part of each alternate cog cut away, may be substituted in their places by hinging them on a pin sliding in bearings in front of the pulleys, with a spiral spring on the left end of the pinions to keep them in gear; but, when necessary to ungear them to set the machine, the pin is forced to the left by means of a lever working in bearings below, having an arm extending across under the rack G', and also a vertical

arm extending up so as to press against the end of the pin when the arm is pressed down by the rack G', when necessary to ungear them to set the machine.

Having thus fully described the nature and object of this my invention, what I claim as new, and desire to secure by Letters Patent, in a machine for adding figures, is—

1. In a machine for adding figures, having a metal frame, the fluted cog-roller O' and indicator-pulleys P' S', and T', in combination with the roller-pinion L', wheel K', pinion J', and rack G', for setting the machine, substantially as herein described, and for the purpose set forth.

2. In a machine for adding figures, having a cog-roller, O', and pulleys P', S', and T', the double lever O, with its extended point N', in combination with the stand B', shaft Z, rods Y, and spring A', also the pinions U and three-pointed devices V and W, when arranged, constructed, and operated substantially as and for the purpose set forth.

3. In an adding-machine having a cog-roller, O', pulleys P', S', and T', the combination of the levers E, springs F, lever H, cog-segments G, and plates I with the flanges K, substantially as herein described, and for the purpose set forth.

MICHAEL BOUCHET.

Witnesses:

FRANK PARDON,  
C. HEWITT.