

T. T. STRODE.

Calculator.

No. 30,264.

Patented Oct. 2, 1860.

Fig. 1.

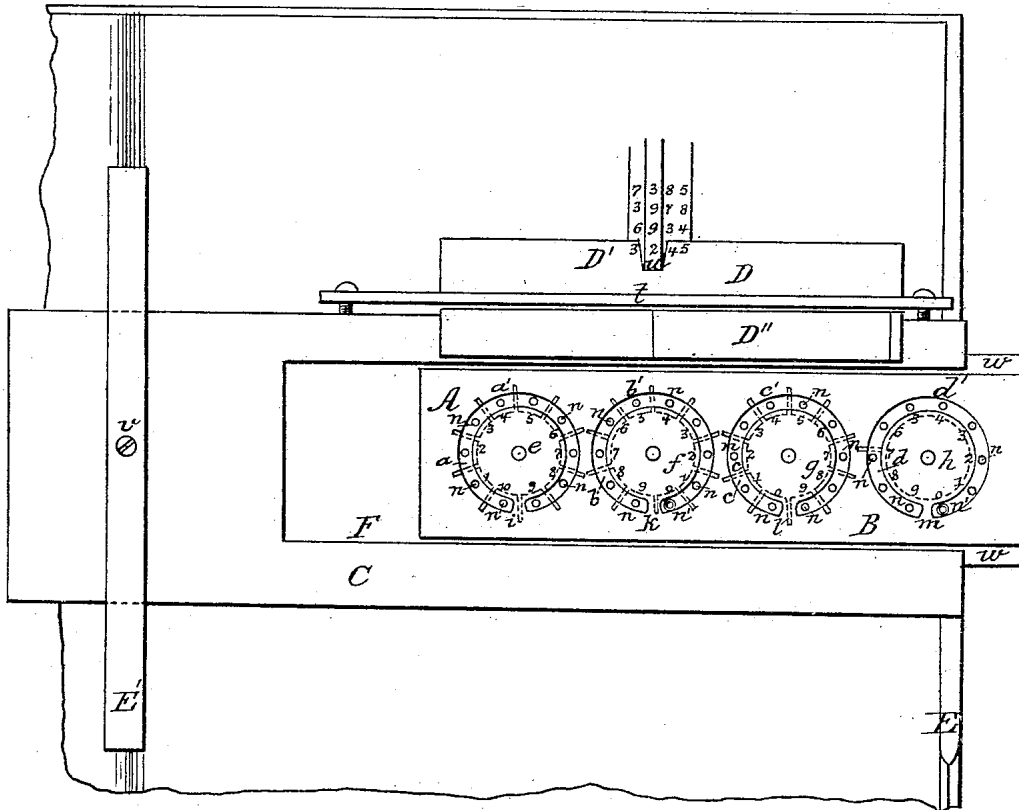
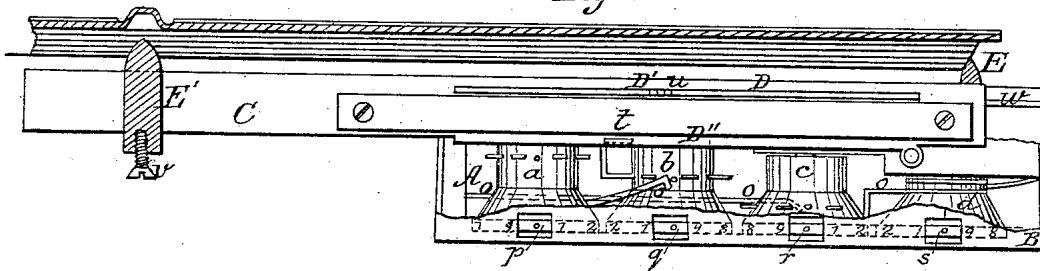

Fig. 2.



Witnesses;
J. W. Coombs,
R. S. Spicer

Inventor;
Thos. T. Strode
per Munroe & Co.
Attorneys.

UNITED STATES PATENT OFFICE.

THOMAS T. STRODE, OF MORTONVILLE, PENNSYLVANIA.

ADDING-MACHINE.

Specification of Letters Patent No. 30,264, dated October 2, 1860.

To all whom it may concern:

Be it known that I, THOMAS T. STRODE, of Mortonville, in the county of Chester and State of Pennsylvania, have invented a new and Improved Machine for Adding Numbers; and I do hereby declare that the following is a full, clear, and exact description of the same, reference being had to the accompanying drawing, forming a part of this specification, in which—

Figure 1, represents a plan or top view of my invention as applied to an account book. Fig. 2, is a sectional front elevation of the same.

Similar letters of reference in both views indicate corresponding parts.

The object of this invention is to produce a simple cheap and reliable device for adding numbers, that can be carried in the pocket with convenience and used in the field or on a wharf or in any place where it may be desirable to have on hand a machine for adding numbers, or which can be used in combination with a platform fitting on an account book so that the several rows of figures on said account book can be added up conveniently and with little trouble.

My invention consists, first, in the combination with the registering apparatus of a platform provided on one end with a stationary guide strip and on the other with an adjustable slide so that it can be conveniently adjusted to the size of the account book with which it is to be used; second, in the arrangement of a notched slide in combination with the platform and with the registering apparatus so that by adjusting said slide the row of figures to be added is kept before the eyes of the accountant.

To enable those skilled in the art to make and use my invention I will proceed to describe its construction and operation with reference to the drawing.

The registering apparatus A, consists of four or more wheels *a, b, c, d*, which are arranged in the interior of a case B. The face plate of this case is provided with a series of annular slots *a', b', c', d'*, equal in number to the number of the wheels and with their outside diameters equal to the diameters of the wheels. The circular plates *e, f, g, h*, which form the centers of these annular slots, connect with the main portion of the face plate by narrow strips *i, k,*

l, m, and each of these circular plates is marked on its face with figures from 0 to 9 and each of the wheels is provided with ten holes *n, n'*, in its face and drilled in circles, which coincide with the middle of the annular slots *a', b', c', d'*, as clearly shown in Fig. 1.

If a pin is inserted into one of the holes *n*, for instance in the hole opposite the figure 7, on the circular plate *e*, the wheel *a*, can be turned in the direction of the arrow marked on its face, until the pin by striking the connecting strip *i*, stops the progress of the wheel. In the same manner each of the other wheels can be turned in the direction of the respective arrows marked on each of the wheels in Fig. 1, spring dogs *o*, being provided to prevent the wheels turning in the wrong direction. One of the holes *n'*, on the face of each wheel represents the naught and it is distinguished by a circle around it or by any other appropriate mark. Each of the wheels *a, b, c, d*, is provided with ten teeth and a carrying tooth on each of the wheels *d, c*, and *b*, produces for each complete revolution of one of these wheels $\frac{1}{10}$ of the next preceding wheel that is to say; one complete revolution of the wheel *b*, produces $\frac{1}{10}$ of a revolution of the wheel *a*, and the complete revolution of the wheel *c*, produces $\frac{1}{10}$ of a revolution of the wheel *b*, and so on; in short the wheel *d*, represents the unit wheel of the registering apparatus the wheels *c*, gives the tens the wheel *b*, the hundreds and the wheel *a*, the thousands and so forth. Each of the wheels *a, b, c, d*, is also marked on its periphery with figures from 0 to 9, said figures being placed at equal distances, one from the other and opposite to apertures *p, q, r, s*, in the front side of the case (see Fig. 2,) and the position of these figures in regard to the apertures is such, that if the hole *n'*, which indicates the naught on the face of one of the wheels be placed opposite the naught on the appertaining circular plate the naught on the periphery of the said wheel is exactly opposite to the appertaining aperture in the front side of the case and if the wheel is now turned by inserting a pin in the hole opposite to one of the figures say the figure 4 on the appertaining circular plate until said hole comes opposite the naught on the plate, the figure 4 on the periphery of the wheel

will appear opposite the appertaining aperture in the back of the case. If it is now desired, to add together the figures 7 and 5, the apparatus is first adjusted so that all the holes n' , are opposite the naughts on the circular plates and a pin is now inserted into the hole opposite the figure 7, in the face of the wheel d , and the wheel is turned in the direction of the arrow marked on said wheel in Fig. 1 until its progress is arrested by the pin striking against the connecting strip m ; the pin is now inserted into the hole opposite the figure 5, and the wheel is turned again until the pin comes in contact with the connecting strip m , and the figure 1, will now appear opposite the aperture r , and the figure 2, opposite the aperture s , in the back of the case thus registering the correct sum.

With numbers containing tens or hundreds or thousands or with still larger numbers it is desirable to commence the operation on the left hand column and the figures of each column are added up by turning the appropriate wheel in the proper direction as above described and after all the columns have been thus added, the correct amount can be ascertained by looking at the figures exhibited through the apertures p , q , r , s , in the front side of the case. If the operation is commenced on the right hand column, and one of the wheels for instance the unit wheel d , should be left standing with the figure 9 opposite the appertaining aperture s , in the front side of the case, the motion of the next, or tens wheel c , will disturb the position of the preceding or unit wheel and the result will be incorrect.

In order to render the use of this registering apparatus, or adding machine convenient with account books, a platform C, is combined with the case B. The front edge of this platform forms the guide for a slide D, which is constructed of a strip of sheet metal bent twice at right angles and kept in its place by a strip of wood t , that is secured to the edge of the platform as clearly shown in the drawing. One portion D' , of the slide is on a level and in the same plane, or nearly so with the lower surface of the platform, C, and another portion D'' , of the slide rests on the upper surface of the platform, being provided with a handle which serves to move the slide to the desired place.

The platform C, is adjusted to the account book with which the adding machine is to be used by means of two V-shaped guide strips E, E', the strip E being permanently attached to the under surface of the platform and the strip E', being adjustable on the same by means of a set screw v . One of the strips is intended to slide on the edge of the account book and the other in the middle, as clearly shown in the drawing and a

notch u , in the front edge of the slide D, serves to adjust the latter to the column or row of figures to be added.

The case B, of the registering apparatus is provided with two flanges w , one on each side to fit into notches in the sides of a recess F, in the platform C, so that said case can be moved in and out and that the wheel corresponding to a certain column of figures may be brought opposite to or in line with said column. This operation is facilitated by vertical lines drawn on the front side of the case and corresponding with the centers of the several wheels and by a line on the upper part D'' , of the slide D, which stands opposite to the center of the notch u . If it is now desired to add up a series of figures in an account book, the platform C, is adjusted on the desired page of the book by means of the guide strips E, E', and the slide D, is moved so as to bring the notch u , opposite the first or left hand column of figures and if this column represents the thousands the case B, is adjusted in the platform so that the wheel a , comes opposite to said column. One figure after the other of this column is now added by turning the wheel a , by means of a suitable pin as above described, and the several figures in the column are brought before the eyes of the operator one after the other by moving the platform C, down or up on the book from one figure to the other. When the first column is finished the notch u , is brought over the second column and the case B, is adjusted so that the wheel b , comes opposite to this column and to the notch and the second column is now added up in the same manner by operating the wheel b , and so forth with the third and fourth columns, until the whole series of figures has been added up. The result is ascertained by looking at the apertures p , q , r , s , in the front side of the case.

By the application of the notched slide D, each figure is kept before the eyes of the accountant, until by the operation of the proper wheel it has been added, and by giving to the case B, a longitudinal motion in the platform, each wheel can be brought opposite to the column of figures to be added, whereby the operation is greatly facilitated.

This machine is very simple and convenient: the registering apparatus can be used with equal facility independently of the platform when it is desired to register a quantity of lumber or a quantity of grain or of any other article, or it can be used with great advantage and convenience in combination with the platform for the purpose of adding up the numbers in an account book.

Having thus fully described my invention, what I claim as new, and desire to secure by Letters Patent, is—

1. The combination of the registering ap-

paratus A, with the platform C, and V-shaped guide strips E, E', constructed and operating substantially as and for the purpose described.

5 2. The arrangement of the notched slide D, in combination with the registering apparatus A, constructed and operating substan-

tially in the manner and for the purpose herein set forth.

THOMAS T. STRODE.

Witnesses:

SAMUEL GREENWOOD,
JACKSON SWEETEN.