

(No Model.)

2 Sheets—Sheet 1.

M. BOUCHET.
ADDING MACHINE.

No. 314,561.

Patented Mar. 31, 1885.

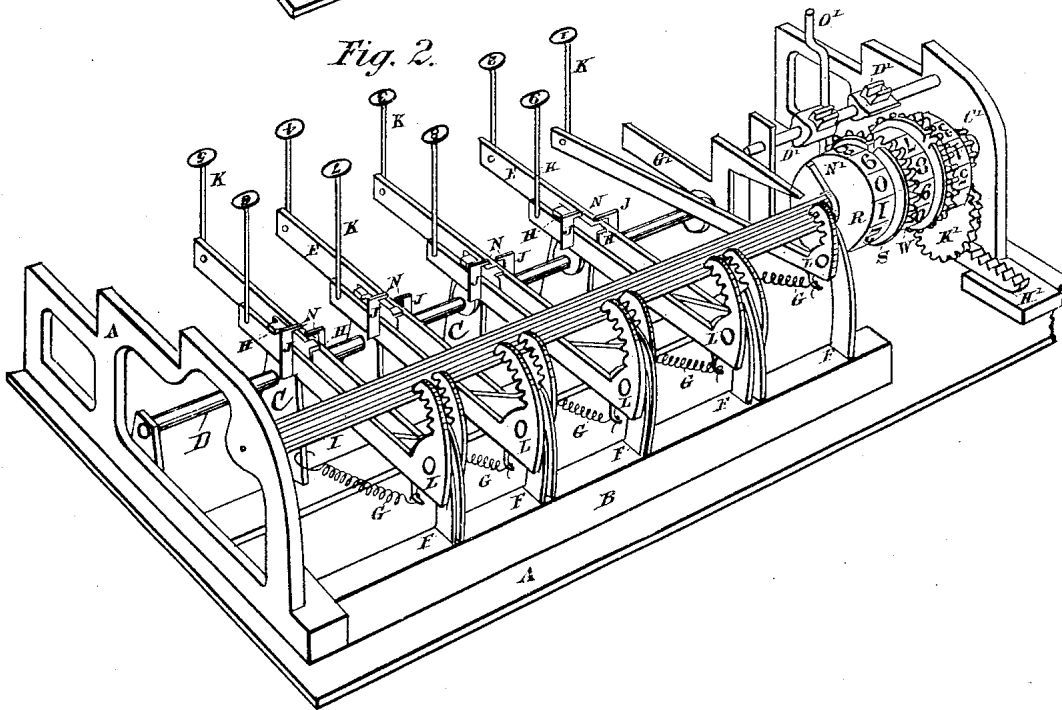
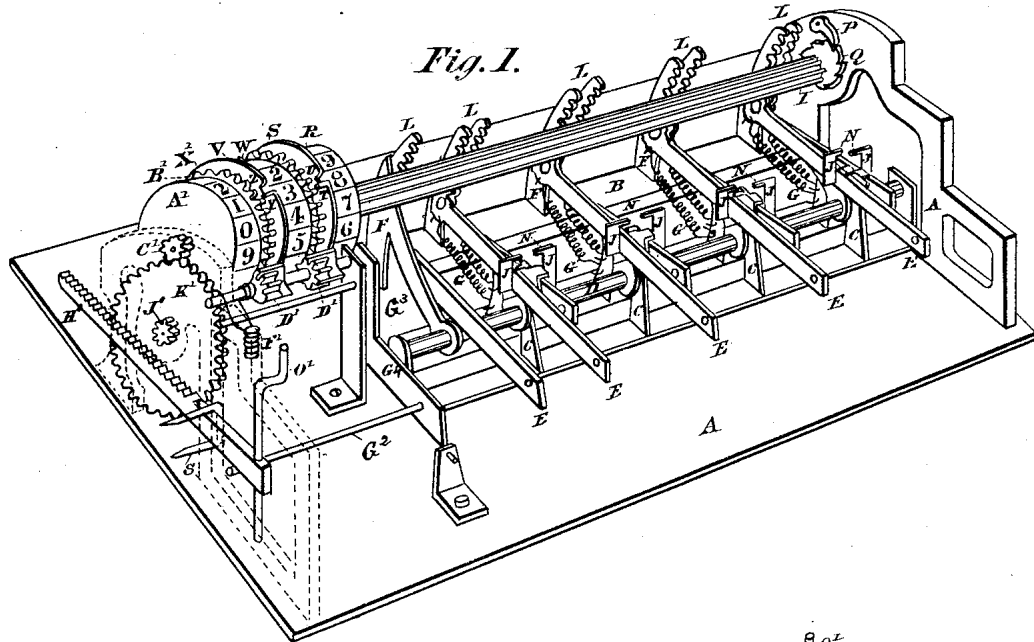

WITNESSES.

Frank Parson
C. Hewitt

INVENTOR.

Michael Bouchet
by J. S. Hewitt
Attorney

M. BOUCHET.
ADDING MACHINE.

No. 314,561.

Patented Mar. 31, 1885.

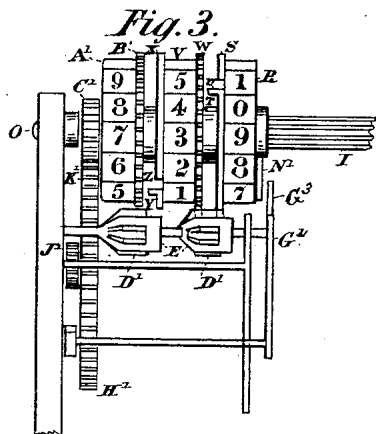

Fig. 7.

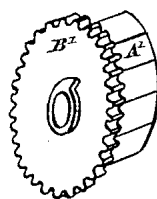

Fig. 8.

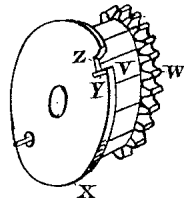

Fig. 6.

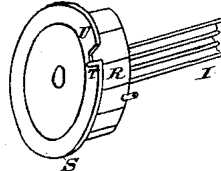

Fig. 4.

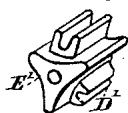
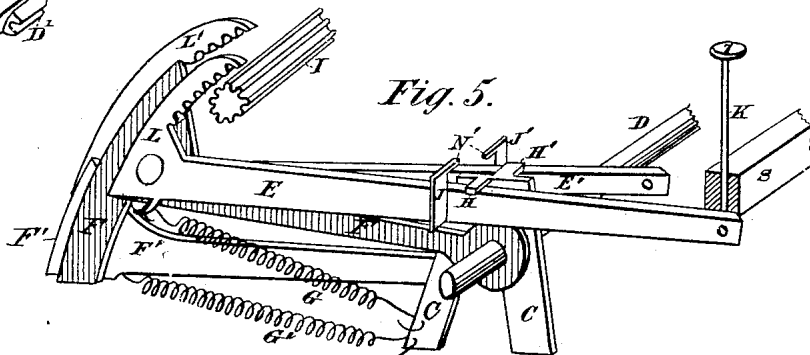

Fig. 5.



WITNESSES.

Frank Dardou
L. Hewitt

INVENTOR.

Michael Bouchet
by J. S. Hewitt
Attorney

UNITED STATES PATENT OFFICE.

MICHAEL BOUCHET, OF LOUISVILLE, KENTUCKY, ASSIGNOR OF ONE-THIRD
TO M. F. MADDEN, OF SAME PLACE.

ADDING-MACHINE.

SPECIFICATION forming part of Letters Patent No. 314,561, dated March 31, 1885.

Application filed April 4, 1884. (No model.)

To all whom it may concern:

Be it known that I, MICHAEL BOUCHET, a citizen of the United States, residing at Louisville, in the county of Jefferson and State of Kentucky, have invented certain new and useful Improvements in Adding - Machines, of which the following is a description.

The object of my invention is to provide a machine for adding figures that will be cheap, durable, reliable, and not liable to get out of order, by means of which much valuable time and labor is saved, thereby assisting book-keepers and others in adding their accounts.

My present invention is in the nature of an improvement upon the adding-machine for which Letters Patent No. 251,823 were granted me January 3, 1882, in which the addition is performed by a series of curved rack-bars acting upon a toothed roller or elongated pinion, and which rack-bars are provided with teeth which give a variable throw to the elongated pinion to turn a numbered wheel one figure, two figures, three figures, &c., up to nine, according to which rack-bar is operated upon.

My invention consists in certain features of improvement, which I will first describe, and then point out in the claims.

Figure 1 is a perspective view of the front of the machine, with the case and other parts removed in order to show the interior arrangement of the several parts. Fig. 2 is a perspective view of the machine, taken from the back to show the operating-racks and foot-rest of the levers. Fig. 3 is a top view of the numbered wheels and the pinion in front of same. Fig. 4 is an enlarged view in perspective of one of the small operating-pinions, showing the three-pointed device on its end. Fig. 5 is a perspective view of a set of operating levers and racks, showing the arrangement of the several parts. Fig. 6 is a perspective view of the first number-wheel (indicating units) and part of the toothed roller or elongated pinion. Fig. 7 is a perspective view of the second number-wheel, (indicating tens.) Fig. 8 is a perspective view of the third number-wheel, (indicating hundreds.)

A represents the frame, which is made of metal and of the form shown in the drawings.

B, Fig. 2, is a raised bar on the bottom of the machine forming a support for the back end of the levers.

C C, Figs. 1 and 2, are standards secured to the bottom of the machine, and D is a round bar passing through them, forming a support for the front ends of the operating-levers, and to which the arms F are hinged. (See Fig. 5.)

E are the operating levers, which are fulcrumed or jointed to the arms F, and just above their fulcrums have upwardly-extending curved rack-bars L, with teeth upon the inner side of the curve. These racks engage with the elongated pinion or toothed roller I. The outer ends of the levers E are provided with vertical studs K, having push-buttons on top, each of which is designated by a different number to correspond with the number of teeth of its rack, and thus giving a throw to the toothed roller I sufficient to turn the number-wheels a distance to measure the same number of spaces as indicated by the number on the push-button. The stud *k* and the end of the lever carrying the stud are held up and the rack L is held away from the toothed roller I by the action of a spring, G, for each of them. When stud *k* is depressed, lever E is rocked on the fulcrum-joint connecting it to arm F, and this initial motion throws rack L into engagement with the toothed roller I. Immediately following the initial movement the lever E and arm F move together, rocking upon the rod D, and the rack, being in engagement with the toothed roller I, turns the same a distance represented by the number of the push-button on that lever. After the toothed roller has been moved, a pawl, P, Fig. 1, engages with a ratchet, Q, on said roller and holds it to its place, and as soon as pressure on the stud K is removed the spring G rocks the rack L out of engagement with the toothed roller and pulls down the rack and arm F about the rod D as a center, allowing the curved ends of arms F to drop down on bar B.

For the sake of compactness, the levers E and their immediate attachments are arranged in pairs, with the exception of the first one, representing units, and shown on the right of Fig. 2. Thus in Fig. 5 the parts marked with

the letters primed, E' F' G', &c., represent a twin or companion structure to the one just described.

R is the first numbered wheel, which represents "units," and is mounted upon the end of the toothed roller I. This wheel is made with a flange, S, in the left side, with a notch, U, on the same, and a trigger, T, projecting laterally. This wheel has figures from 0 to 9 on its periphery, and has a small pin, N', (see Fig. 3,) through the boss.

V is the second number-wheel, turning loosely on an axis. This wheel has a cog-gear, W, on one side and a flange, X, on the other, which flange has a notch, Z, and trigger Y, as shown. This wheel is numbered from 0 to 9, and represents the "tens" denomination.

A' is the third number-wheel, which works loosely on its axis, and has a cog-gear, B'. This wheel is provided with numbers from 0 to 9, and represents the "hundreds" denomination.

I will now describe how the motion of toothed roller I and wheel R is transmitted to the wheels V and A', giving to V one movement to every ten of R, and to A' one movement for every ten of V.

D' D', Figs. 1, 3, and 4, are two pinions, of which the right-hand one connects wheels R and V, and the left-hand one wheels V and A'. As the actions of these are the same, I will only describe the right-hand one. This pinion has a three-cornered projection, E', Fig. 4, at its end, lying in the plane of flange S, belonging to wheel R, and its portion lying in the plane of gear W on wheel V is a toothed gear meshing with said gear W. Now, when wheel R has made nine movements, and it is necessary to give a movement to wheel V to register ten, the trigger T of flange S on wheel R strikes one of the three-cornered projections of pinion D', and this pinion being in gear with the toothed flange W of wheel V, it turns this wheel V the distance of one figure on its periphery, and trigger T then passes by the three-cornered projection, and wheel R goes on registering units until it has made another complete revolution and is ready to register twenty, when the trigger T engages the three-cornered end of pinion D' and gives a second motion to wheel V. In progressing from the tens-wheel V to the hundreds-wheel A', the trigger Y of wheel V operates in the same way upon the left-hand pinion D', and turns the hundreds-wheel once every ten movements (or a complete revolution) of the tens-wheel. Now, to perform an addition of a column of figures of, say, six, seven, and nine, we successively depress the levers bearing these numbers, and the racks of these several levers, by their increased number

of teeth, turn successively the toothed roller I a distance that shows, first, six on the units-wheel; second, three on the units-wheel and one on the tens, representing the addition of six and seven, or thirteen, and, third, two on the units-wheel and two on the tens, representing the addition of thirteen and nine, or twenty-two. After the addition has been performed, the number-wheels are set to zero by the following mechanism, referring to Figs. 1 and 3: The shaft bearing pinions D' D' is made longitudinally adjustable, so that when moved to the left the three-cornered end of each pinion is moved out of range of the trigger of its actuating-wheel. To do this an arm, G², bears against the right-hand end of this shaft and is attached below to a rocking plate, G¹, fulcrumed in supports (see Fig. 1) below and provided with a lateral arm, G³. Now, when arm G² is depressed, G¹ is rocked, and G³ presses against the end of the shaft of pinions D' and shifts them laterally. To depress arm G², a rack-bar is arranged to slide in a staple, s, and the rear end of said rack-bar rides upon the end of arm G², while a handle, O', projects above through a slot in the case. (Not shown.) Now, to set the number-wheels, it is only necessary to depress handle O' and pull it toward you, which action gives the necessary motion to arm G² to disengage the pinions D', and also causes rack-bar H' to fulcrum on the staple s, which throws its back end up into contact with pinion J', and as the rack H' then is drawn out it turns pinion J' and wheel K², and the latter turns pinion C' and the numbering-wheels, bringing them back to zero, the wheel R being stopped at 0 by the arm G³ engaging with the pin N' in Fig. 3.

Having thus described my invention, what I claim as new is—

1. The operating-levers E, having curved racks L, with teeth upon the inner side of same, in combination with toothed roller I, rod D, arms F, hung upon rod D and jointed to the levers E, and the springs G, as and for the purpose described.

2. The combination of the pinions D' D', with three-cornered projections E' E' at one end, the longitudinally-adjustable shaft carrying the same, the numbering-wheel R, with stop-pin N', and the rocking plate G¹, with arm G², adapted to push the pinion-shaft endwise and simultaneously engage the pin N', the arm G³, and the rack mechanism H' O', for setting the wheels, as described.

MICHAEL BOUCHET.

Witnesses:

FRANK PARDON,
C. HEWITT.