

(No Model.)

D. E. FELT.
ADDING MACHINE.

No. 396,034.

Patented Jan. 8, 1889.

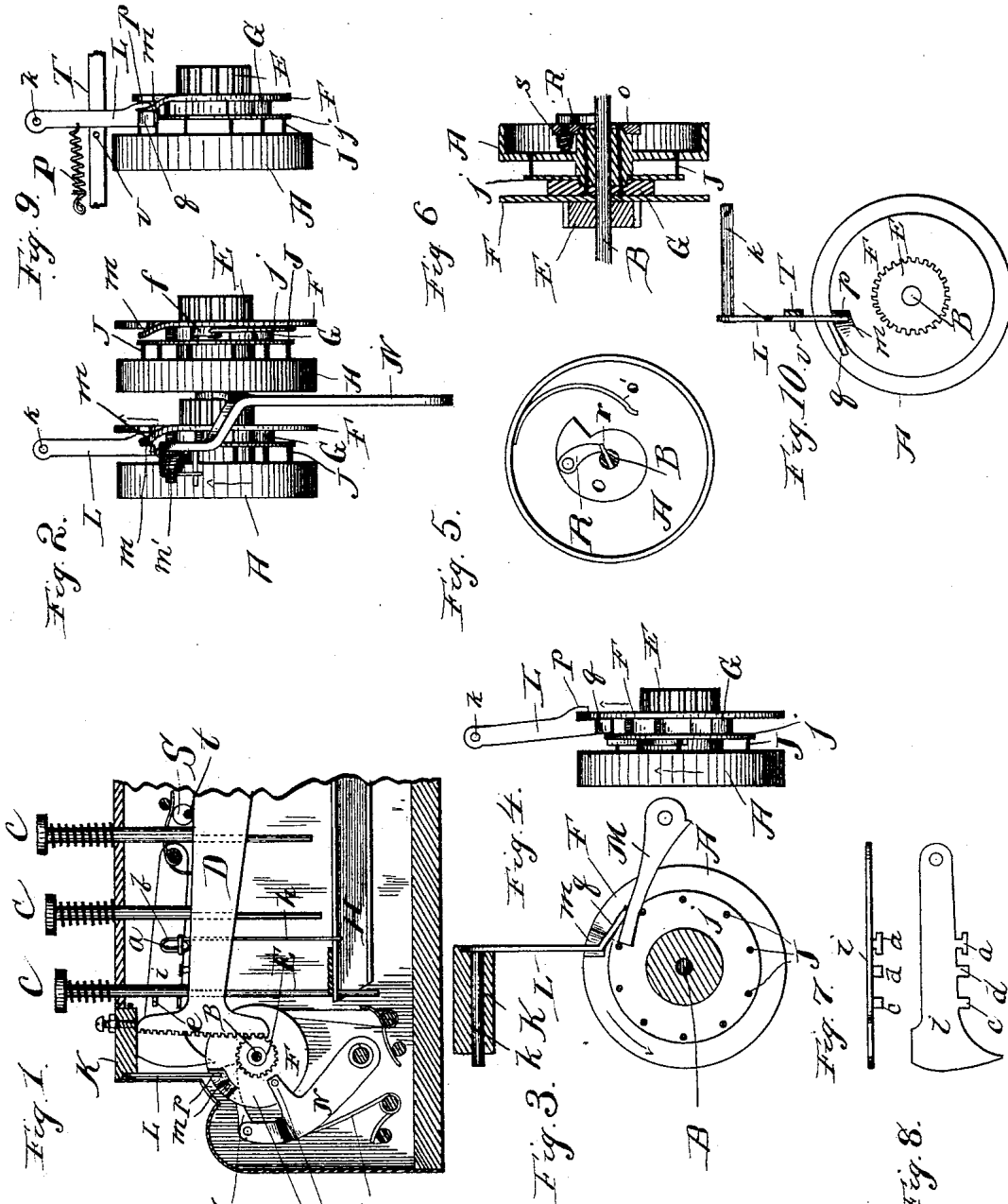

Witnesses:
Geo. C. Curtis
Chas W. Nichols

Inventor:
Dorr E. Felt.

By Munday Evans & Adcock
his Attorneys:

UNITED STATES PATENT OFFICE.

DORR E. FELT, OF CHICAGO, ILLINOIS, ASSIGNOR, BY DIRECT AND MESNE ASSIGNMENTS, TO HIMSELF AND ROBERT TARRANT, OF SAME PLACE.

ADDING-MACHINE.

SPECIFICATION forming part of Letters Patent No. 396,034, dated January 8, 1889.

Application filed May 31, 1887. Serial No. 239,781. (No model.)

To all whom it may concern:

Be it known that I, DORR E. FELT, a citizen of the United States, residing at Chicago, in the county of Cook and State of Illinois, have invented a new and useful Improvement in Adding-Machines, of which the following is a specification.

This invention relates more particularly to the construction of the stop-motion devices for preventing overrotation under the impulses of the carrying mechanism, and is an improvement upon the devices designed for that purpose in my invention shown in application No. 230,653.

The nature of the invention is fully set forth in the following description and shown in the accompanying drawings, in the latter of which—

Figure 1 is a partial vertical longitudinal section of a machine embodying my present improvements. Fig. 2 is a front elevation of two adjacent numeral-wheels and the carrying devices. Fig. 3 is a partial vertical section taken upon the other side of the disk than that shown in Fig. 1. Fig. 4 is an elevation of a numeral-wheel, the parts being rotated to a different position from that of Fig. 2. Fig. 5 is a side view of one of the numeral-wheels, and Fig. 6 is a cross-section through the same and its accompanying ratchets, &c. Figs. 7 and 8 are detail views showing an improved construction of the detents for preventing overrotation under power received from the keys. Fig. 9 shows a modified construction, and Fig. 10 a side view of the same.

In said drawings, A represents the numeral-wheels; B, the shaft upon which the wheels are mounted; C C, the operating-keys; D, the vibrating segment-levers operated by the keys; E, the pinions meshing with said levers, and F the disks, carrying spring-depressed pawls *f*, (see Fig. 2,) acting upon ratchets G, rotating the numeral-wheels.

H represents the stop-levers, struck and operated by the portions of the keys projecting through the segment-levers, as shown, and connected to the vibrating detents *i* by the rods *h*, the detents engaging the equispaced teeth or wires J, secured in the disks *j* and

the numeral-wheels A, and preventing overrotation under the impulses received direct from the keys. The detents *i* and the heads *a*, with which the loops *b* of rods *h* engage, are integral, the blanks from which they are cut being shown in Fig. 8, and the heads being then bent at right angles to the plane of the detents. The same is also true of the projections *c* and *d* upon the detent, one engaging with the pin *e* upon the lowest one of each series of keys, and the other may engage with the segment-lever as the latter rises to its normal position, and thus insure the lifting of the detent after it has served its office of stopping the rotation.

Swinging upon horizontal pivots *k* in the cross-bar K are a series of depending arms, L, which are forked at their lower ends, so as to ride the rim of the disks F. The disks move only in obedience to the segment-levers and never turn entirely around their axis; but they are provided at one point with a lateral bend, *m*, in their rims converting them into cam-disks, such bend being located so that the arms L will be swung thereby into the lateral position (see Fig. 2) when the disks are at rest. The object of this feature will be made apparent in the next paragraph.

N are the carrying-levers, each provided with an actuating-spring, *n*, an arm, O, riding upon the cam *o*, and a pivoted spring-depressed pawl, M. The cams *o* are attached to the numeral-wheels and gradually force the carrying-levers away from the wheels as the time approaches for the carrying operation to take effect, and the pawls M engage with the wires or teeth J, already mentioned. Through the medium of the teeth J and the pawls M the numeral-wheels are actuated in carrying. The pawls M also act, in conjunction with the feet *q*, formed upon the arms L, to stop the numeral-wheels against overrotation when actuated by the pawls. The nature of this stopping operation is fully apparent from Fig. 3, where the pawl M is shown as resting upon top of the tooth J next in order, with its end against the one last acted upon and the foot *q* sitting down upon the pawl and preventing its rising. This lock, which is in force when the parts are at rest, is released whenever the

disks F are rotated, such rotation resulting in moving the arms L from over the pawls M. It is also released by the withdrawal of the pawls with the backward movement of their carrying-levers, the pawls being shaped to admit of this withdrawal in a lengthwise direction without interfering with the arms or the wheels, and when so withdrawn the pawls engage the next teeth J and the wheels may then be carried by the carrying levers and pawls one number, the stoppage taking effect again as soon as the pawls have carried such next teeth J to the position shown in Fig. 3.

Instead of having the arms L forked, so as to be moved in both directions by the cam-disks F, said disks may be reduced in diameter, as shown in Figs. 9 and 10, and the arms be provided with a single leg or extension, *p*, upon one side of the disks and the contact between said leg and the disks be maintained by springs P. In this modification the feet *q* lie in a plane tangential to the rim of the disks, where they do not interfere with the latter, as more particularly illustrated in Fig. 10.

In setting the wheels preparatory to an adding operation I employ pawls R, mounted upon the side of cams *o*, which engage with the axial projections *r* when the axis has been rotated to the position occupied by the pawls, and after such contact the wheels from which the pawls are held will be rotated with the axis until they have reached the zero position. These pawls are hinged upon the cams and are provided with springs *s*, mounted upon and secured to their axes, (see Fig. 6,) and through such springs are kept in position for duty, though easily thrown out when necessary. In setting, also, it is necessary to first release the wheels from the lock caused by the arms L and the carrying-pawls M, and this I accomplish in the construction employing the forked arms L by a series of rotatable cams, S, mounted upon a cross-shaft, *t*, extending to the outside of the box or case inclosing the machine and there provided with some convenient device, which I have not deemed it necessary to illustrate, for operating it, said cams bearing upon the segment-levers and acting, when turned a half-revolution, to depress all said levers sufficiently to carry all the arms L away from the locking position. The same result of moving the arms laterally is accomplished with the modified construction shown in Figs. 9 and 10 by a sliding cross-bar, T, having pins *v*, engaging with the arms L and adapted to force the latter laterally against the power of the spring P.

By employing the disks *j* to support one end of the ratchet-teeth J, I am enabled to reduce the ratchets G very materially from the diameter required when said teeth were secured in said ratchets G.

Springs *m'* are mounted upon the axis of the pivoted pawls M and act to depress said

pawls, and cams *o'*, located upon the side of the numeral-wheels, are employed to return the arms O to the center after they have passed the outermost point of cams *o*.

I claim—

1. In an adding-machine, the combination, with the numeral-wheels and the carrying mechanism, embracing pawls and ratchet-teeth for actuating said wheels, of a stop for preventing overrotation by the carrying mechanism, consisting of arms movable into locking position with said pawls, substantially as set forth.

2. The combination, in an adding-machine, with the numeral-wheels having equispaced teeth J, of the arms L and pawls M, substantially as set forth.

3. In an adding-machine, the combination, with the numeral-wheels having equispaced teeth J, of the cam-disks F, the arms L, and pawls M, substantially as set forth.

4. In an adding-machine, the combination, with the numeral-wheels having the teeth J and the carrying pawl and lever, of the locking-arm and its moving devices, substantially as specified.

5. The combination, in an adding-machine, and with the numeral-wheels and setting mechanism thereof, of the locking devices consisting of arms L and pawls M and cam-disks for releasing the former, substantially as set forth.

6. The combination, with the stop devices L and M, acting in conjunction with ratchet-teeth J, of said teeth J, the cam-disks, the pinions actuating the disks, the segment-levers, and the cams S, substantially as and for the purpose specified.

7. In an adding-machine, the combination, with the numeral-wheel and its carrying mechanism, of a stop for preventing overrotation under the impulse of the carrying mechanism, consisting of an arm movable into position to act with the actuating-pawl of the carrying mechanism in locking the numeral-wheel, and means for moving said arm out of such position at will, substantially as set forth.

8. In an adding-machine, the combination, with the numeral-wheels and their carrying mechanism, of a stop device consisting of an arm acting in conjunction with the pawl of the carrying mechanism to lock the numeral-wheels, said pawl being withdrawable from the locking position for renewing the carrying operation, substantially as set forth.

9. The locking-detents *z*, having heads *a* formed on its edges and integral therewith, in combination with the rods *h* and the stop-levers H, substantially as set forth.

DORR E. FELT.

Witnesses:

EDW. S. EVARTS,
EDMUND ADCOCK.