

(No Model.)

3 Sheets—Sheet 1.

J. H. SCHNARRENBERGER.
ADDING MACHINE.

No. 409,710.

Patented Aug. 27, 1889.

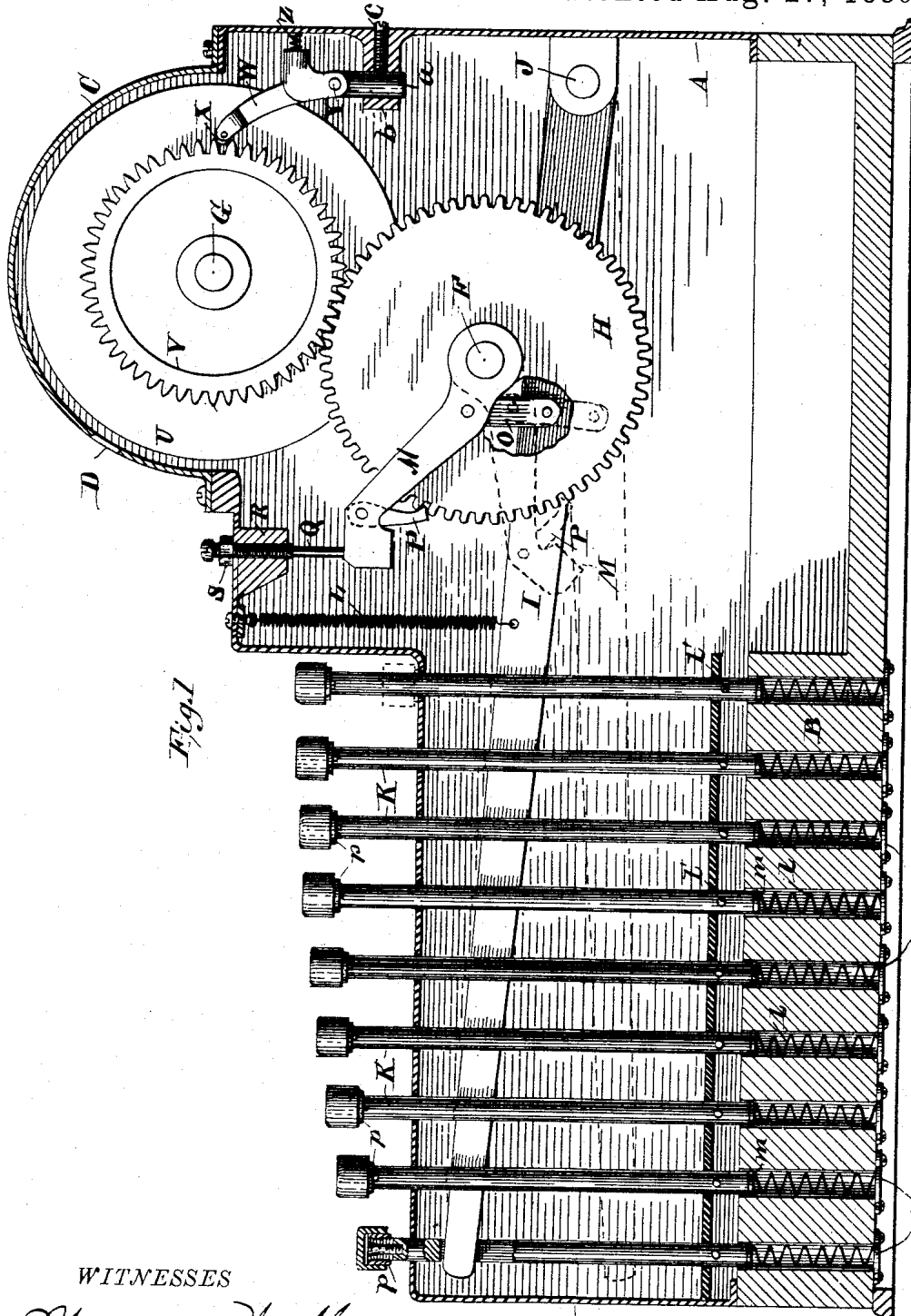

Fig. 1

WITNESSES

Warren Hull
John Fenwick

Jacob H. Schnarrenberger
Inventor
H. Toulmin Attorney

(No Model.)

3 Sheets—Sheet 2.

J. H. SCHNARRENBERGER. ADDING MACHINE.

No. 409,710.

Patented Aug. 27, 1889.

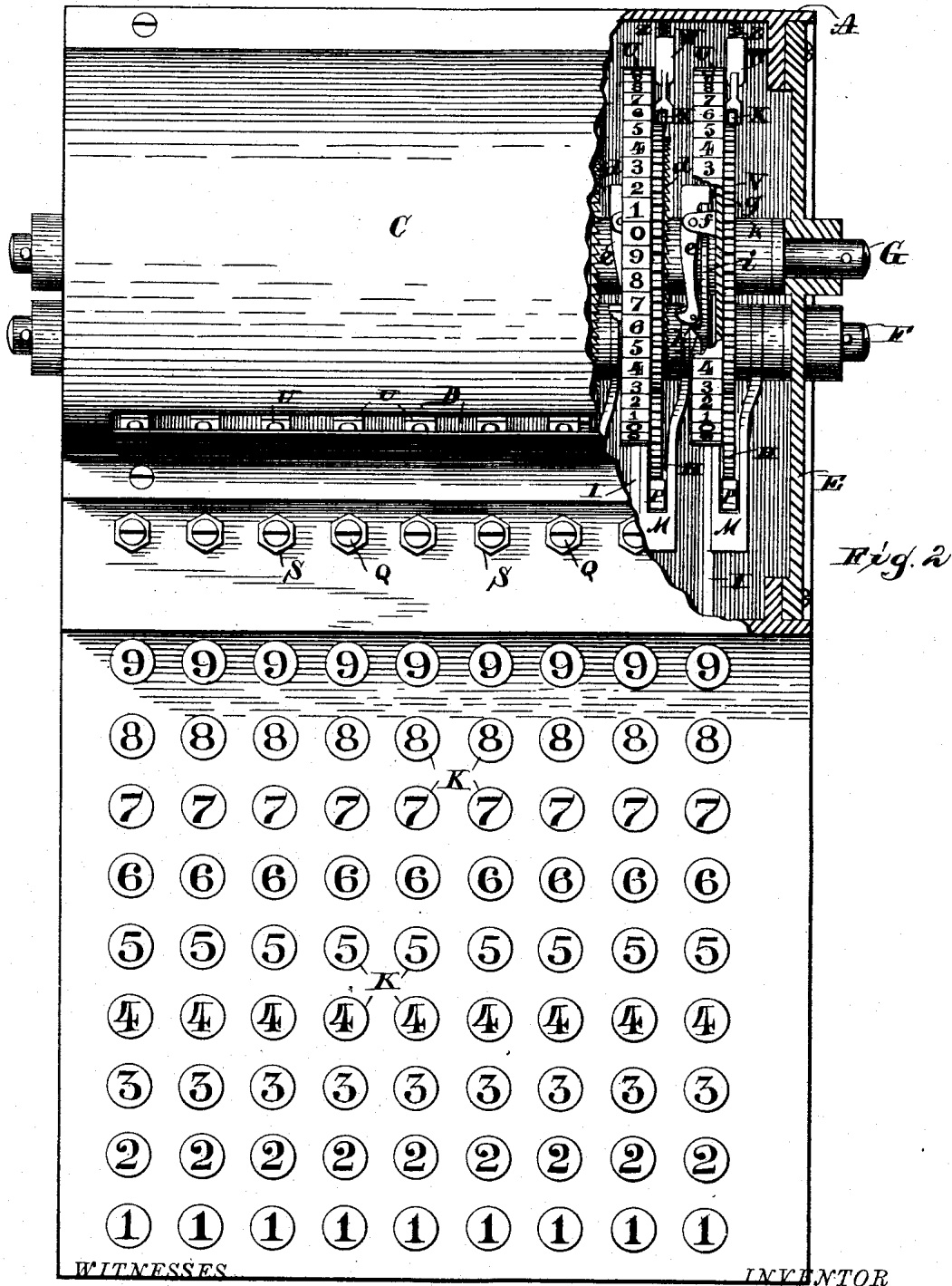

Fig. 2

Warren Hull.
J. E. Fenwick

Jacob H. Schnarrenberger.
H. A. Toulmin.
Attorney.

J. H. SCHNARRENBERGER.
ADDING MACHINE.

No. 409,710.

Patented Aug. 27, 1889.

Fig. 3

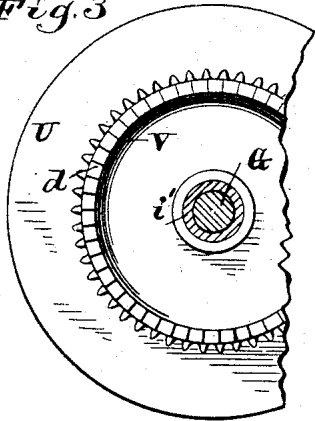

Fig. 4

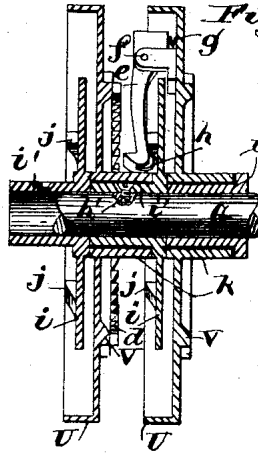

Fig. 5

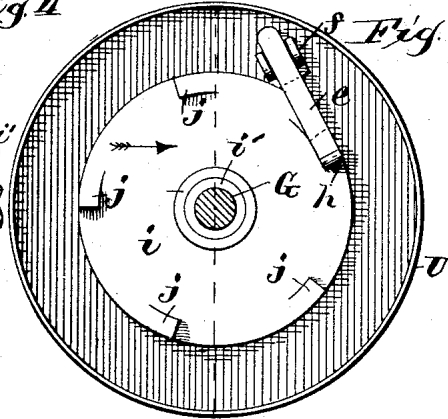

Fig. 6

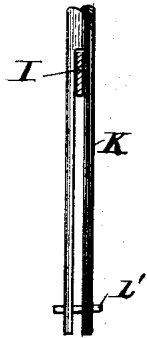

Fig. 7

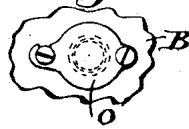

Fig. 8

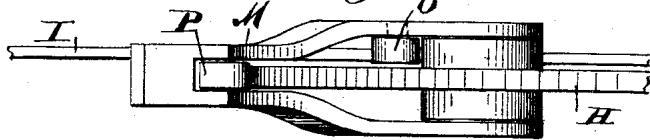

Fig. 10

| |
|---------------|
| 95.00 |
| <u>101.04</u> |
| 196.04 |

Fig. 9

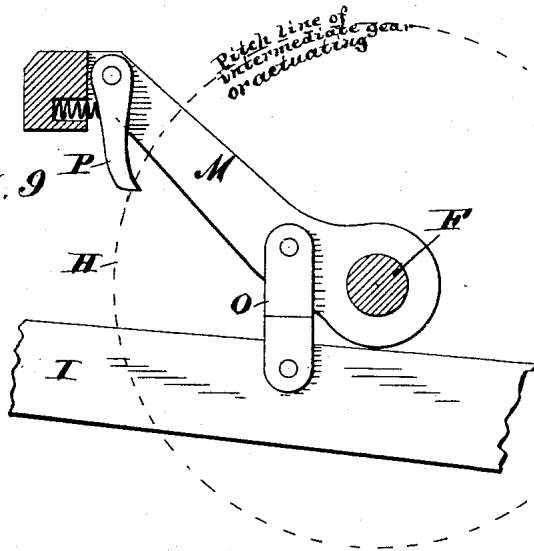

Fig. 11

| |
|----------|
| 4 |
| <u>3</u> |
| 2 |
| <u>1</u> |
| 10 |

WITNESSES

Warren Hull.
John Fenwick

INVENTOR

Jacob H. Schnarrenberger
H. A. Fulmin
Attorney

UNITED STATES PATENT OFFICE.

JACOB H. SCHNARRENBERGER, OF SPRINGFIELD, OHIO, ASSIGNOR, BY DIRECT AND MESNE ASSIGNMENTS, TO HIMSELF AND THOMAS REYNOLDS, OF SAME PLACE.

ADDING-MACHINE.

SPECIFICATION forming part of Letters Patent No. 409,710, dated August 27, 1889.

Application filed November 27, 1888, Serial No. 292,007. (No model.)

To all whom it may concern:

Be it known that I, JACOB H. SCHNARRENBERGER, a citizen of the United States, residing at Springfield, in the county of Clark and State of Ohio, have invented certain new and useful Improvements in Adding-Machines, of which the following is a specification, reference being had therein to the accompanying drawings.

This invention relates to certain new and useful improvements in adding-machines; and the object or purpose of the invention is to mechanically add together figures, whether the figures be arranged in single columns or in numerous columns, in which latter instance all of the columns are added at the same time, so that the result will show a footing of all the columns just as if they had been added one column at a time, as is usually done.

The present invention is designed as an improvement upon the machine for which Letters Patent No. 391,430 were granted to me on October 23, 1888, for adding-machines, and in two senses—first, in that of an improved organization, and, second, in that of an improved construction respecting certain details, both of which will be hereinafter more fully pointed out.

In the accompanying drawings, forming a part of this specification, and on which like reference-letters indicate corresponding parts, Figure 1 represents a side elevation of my improved machine with one side of the casing removed and certain of the parts in section; Fig. 2, a plan view of the machine with a portion of the casing broken away in order to show some of the interior parts; Fig. 3, a side view of one of the adding-disks; Fig. 4, a diametrical sectional view of two adding-disks and two cam-disks, showing a portion of the main shaft and one of the engaging-dogs in elevation; Fig. 5, a side elevation of one of the adding-disks with its engaging-dog and one of the cam-disks, looking from the opposite side of Fig. 2; Fig. 6, a detail view of one of the keys, showing one of the key-levers in section; Fig. 7, an inverted plan view of a portion of the base, showing a cap which supports the key-spring; Fig. 8, a detail view of one of the actuating-arms; Fig. 9, a side ele-

vation in detail of the actuating-arm, its pawl, the link, and a portion of a key-lever connected to the arm by said link, a portion of the arm and its supporting-lever being in section; and Figs. 10 and 11, diagrams of examples described in connection with the operation of the machine.

A designates the general frame or casing of the machine, inclosing a wooden or other suitable base B, and having a cover C, provided with a sight-slot D. The side pieces of the casing, as seen at E in Fig. 2, are fashioned to form convenient bearings for the arbors F and G, which carry, respectively, a series of actuating-gears and a series of alternating adding-disks and cam-disks. I will first describe the former. These gears are designated by the letter H, of which there is one for each adding-disk, and the whole series is rotatably mounted on the shaft F, each gear independently of the other. For each of these gears there is a key-lever I, extending from a suitable fulcrum J past its gear-wheel to the front of the machine, where it is engaged at intervals by keys K, as seen in Fig. 1. These levers I are each normally sustained in the position shown in Fig. 1 by a spiral or other form of spring L for each lever, so that after the lever is depressed in the manner hereinafter pointed out it will automatically return to its normal position ready for another depression. To each of these levers is also connected an actuating-arm M, as by a link O. (See Figs. 1 and 9.) These arms are composed of two members, as seen in Fig. 8, which embrace a gear-wheel and pivot upon the arbor F. The free ends of these arms carry spring-actuated pivoted pawls P, which engage with the teeth of the respective gear-wheels H during the descent of the respective levers I, so as to partially rotate said gear-wheels, each pawl skipping over the teeth of the wheels during the return movement of the levers I, coincident to which movement is the return movement of the arms M through the link-connection O.

It is important that the normal or elevated position of the arms M shall be at a certain predetermined and fixed altitude. For this purpose I provide a series of adjustable stops

consisting of screws Q, fitted to threaded openings in a rib or boss R of the casing A, and provided each with a jam-nut S. Any other form of stop would do; but this construction is convenient, because it admits of adjusting the stop to compensate for any wear that may take place in the parts, so that the pawls P will always move the gears H the same proportion of a revolution. The result of these partial rotations is to impart an intermittent rotation to the adding-disks U by meshing with the gear wheels or rims V, carried by the adding-disks U. These wheels or rims are prevented from accidental rotation or revolving too far, as a result of momentum, by means of a spring-actuated detent W, as clearly seen in Fig. 1, an anti-friction roller X being carried by the detent of proper diameter to drop between the teeth of the rim V and roll out of the same when the rim is rotated. These detents are pivoted at Y and actuated by a spring Z, the pivot being sustained by a block a, detachably held in a rib or web b by a set-screw c.

Each adding-disk U is provided upon its periphery with the numerals 0 to 9, running through the series, as 0, 1, 2, 3, 4, 5, 6, 7, 8, 9. These figures are termed "groups," of which groups there are five upon the periphery of each disk. One side of each disk is provided with fifty ratchet or crown teeth d, formed on the face of the gear-rim V opposite to the preceding disk to the right, as seen in Figs. 2 and 4. Each adding-disk, save the last one to the left, is provided on the side opposite to the said crown-teeth of the next disk with an engaging-dog e, occupying the position illustrated in Figs. 2, 4, and 5, and pivoted at f, a spring g serving to keep the anti-friction roller h, carried by the heel of the dog, in contact with the adjacent face of a fixed cam-disk i, having inclined cam-surfaces j at such intervals as will cause the dog to be thrown into engagement with the crown-teeth of the next disk to the left as 9 on the disk carrying the dog e moves from and 0 appears opposite the sight-slot. From this it will be understood that when a dog is thus moved laterally one adding-disk is locked or positively engaged with the other—i. e., an adding-disk to the right is engaged with the next adding-disk to the left, whereby the movement of the one to the right causes the one to the left to move.

It should be observed that, there being but five of the cam-surfaces j upon each of the disks i, and there being about as much space between the vertical terminations of any two of said cam-surfaces as there is distance between ten of the teeth d on the adding-disks, an engaging-dog e will be projected once at every ten movements of each disk, or, in other words, will be projected only when 0 of its disk reaches the point where the figures are read in adding, and therefore that one adding-disk will only project its dog into engagement with the next adding-disk and move the

latter when the former is passing from the numeral 9 to 0 across the sight-slot D, as above suggested.

Referring to the position of the dogs e, I would observe that they are preferably arranged at a tangent to the periphery of the disks i.

From Fig. 4 it will be seen that each cam-disk i has a collar i', which fits upon the shaft or arbor G and is held against rotation by a set-screw h', and also that each adding-disk has a similar collar k, which turns on the collar of the cam-disk adjacent to the adding-disk to the right. This is a very feasible construction, as it admits of properly spacing the adding-disks and cam-disks relatively by turning the edges of the collars to suit the desired spaces; therefore, while the adding-disks are mounted upon the arbor G, they are only indirectly so mounted. The last collar i' to the right in Fig. 4 has the disk portion omitted.

Referring now to the keys K, it will be seen from Figs. 1 and 6 that their lower portions are longitudinally slotted to receive the levers I and to allow the movement of each lever I when actuated by any key in any particular row without disturbing the other keys in that row. A pin l', by coming in contact with the portion of the general frame of the machine, prevents each key from being raised too high by its spring.

The lower ends of the keys are fitted to vertical openings in the base B, and are normally supported and returned to normal position by spiral springs l, a washer m being interposed to keep the springs from catching in the slots in the keys. The lower ends of these openings are closed by a suitable cap-plate o, hinged to the bottom of the base B, so as to be removable from beneath the holes, as seen in Figs. 1 and 7, so as to remove the springs should they become unduly compressed and require to be repaired or replaced by new ones. This feature of construction saves taking the frame of the machine apart to remove the keys so as to then remove the springs.

It is necessary that the keys should have stops to limit their descent, and it is convenient that these stops should be adjustable. These requisites are complied with by means of the collars p, screwed upon the upper ends of the keys, which are vertically slotted, as seen in Fig. 1. The key-caps, carrying the numerals, are fitted upon the collars p.

From Fig. 2 it will be seen that there are nine rows of keys—a row to each adding-disk—and that each row is composed of nine keys, (designated 1 2 3 4 5 6 7 8 9 consecutively.)

I will now give an example of the operation of the machine. Referring to the diagram, Fig. 10, in which \$101.04 are to be added to \$95.00, the operator depresses key marked 4 at the extreme right hand, which moves the first disk to the right from 0 to 4, presenting 4 in the sight-slot. 0 being the next figure,

and there being no key designated or marked 0, he does not disturb the second disk to the left. In the third or hundreds order he depresses the key marked 1, which moves the disk one space and presents 1 in the sight-slot instead of 0. The next figure being 0, he does not disturb the fourth or thousands disk for the above reason. The next figure being 1, he depresses the key marked 1 in the fifth order, and moves that disk one space and presents 1 in the sight-slot. The figures will then read "\$101.04." Going on up the column in the example, he observes 5 in the third or hundreds order. The operator then depresses the key marked 5 in the third order, which moves the third disk five spaces, which, added to the one space already moved from 0, presents 6 in the slot. The next key he depresses is marked 9 in the fourth order, which moves the fourth disk from 0 to 9. Thus \$196.04, the sum of \$101.04 and \$95.00, is shown in the slot.

Another example is given in diagram Fig. 11, to add which the units-key marked 1 is depressed, which moves the units-adding disk one notch. The units-key marked 2 is then depressed, which moves the said disk two notches farther, making three notches in all. The units-key marked 3 is then depressed, which moves the disk three notches farther, making six in all, and, finally, the units-key marked 4 is depressed, which moves the disk four notches farther, making ten in all, which will bring 0 on the units-disk to view through the sight-slot. As 9 passes from the slot 0 appears therein. The engaging-dog *e* is projected outward, by means of a cam *j* on the disk *i*, into the teeth *d* of the next disk to the left, and said disk is moved one notch, which will bring the numeral 1 in said slot. Thus 1 and 0 appear, designating 10, the sum or result of the said example.

It will be observed that the number of disks illustrated is nine, which will permit the addition of figures the sum of which will amount to \$9,999,999.99. Of course this is not the limit, as additional disks will carry out the sum.

There are various features of construction herein described which may be readily changed without departing from my invention. I do not, therefore, wish to be confined to these comparatively minor matters. An essential of my invention, however, resides in the interposition of actuating-gears between the key-levers and the adding-disks, combined with the necessary adjuncts to impart motion to these gears and transmit it from them to the adding-disks.

Having thus fully described my invention, what I claim as new, and desire to secure by Letters Patent, is—

1. In an adding-machine, the combination,

with an arbor, a series of independent rotatable adding disks mounted thereon and respectively bearing groups of figures from 0 to 9, inclusive, and provided each with an annular row of teeth on one side, and a dog pivoted to the side opposite the teeth, save on the last disk to the left, and a fixed cam between each two of the rotatable disks mounted on said arbor, the cam-surfaces of said disks being opposite the numerals 0 and 9 to throw the dog of one disk into engagement with the teeth on the next disk to move it from 0 to 1 as the first-named disk passes from 9 to 0, of a like series of independent gear-wheels meshing with the adding-disks, respectively, a pivoted key-lever for each disk, a pivoted actuating-arm connected to each lever and carrying a pawl which engages with the adjacent gear-wheels, a spring to return each key-lever to normal position, keys for each key-lever agreeing with the groups of figures on the respective disks, and a locking-pawl for each disk.

2. In an adding-machine, the combination, with a series of independent rotatably-mounted adding-disks respectively bearing groups of figures from 0 to 9, inclusive, and provided each with an annular row of crown-teeth on one side and a gear-rim on the other side, a fixed cam-disk between each two of the rotatable disks, and an engaging-dog carried by each of said adding-disks (save the last one to the left) and arranged to be actuated by said cam-disks to engage the crown-teeth of the next disk to the left to move said disk to the left from 0 to 1 as the first-named disk moves from 9 to 0, of a series of independent gear-wheels meshing, respectively, with the gear-teeth of the adding-disks, a pivoted key-lever and a pivoted arm for each gear-wheel, connected together and arranged to actuate the gear-wheel by a depression of the lever, stops to limit the upward movement of said arms, and a detent to prevent the adding-disks from accidentally rotating.

3. In an adding-machine, the combination, with an arbor, of a series of independent rotatable adding-disks, each carrying at one side an annular series of gear-teeth and a like series of crown-teeth, and at the other side a spring actuated and engaging dog, and a series of fixed cam-disks mounted between the adding-disks and having cam-surfaces by which said dogs are projected into engagement with said crown-teeth, the gear-teeth admitting of the adding-disks being actuated by the gear-wheels.

In testimony whereof I affix my signature in presence of two witnesses.

J. H. SCHNARRENBERGER.

Witnesses:

J. C. COVERT,
L. S. BACON.