

(No Model.)

2 Sheets—Sheet 1.

H. COOK.
ADDING MACHINE.

No. 430,001.

Patented June 10, 1890.

Fig. 1.

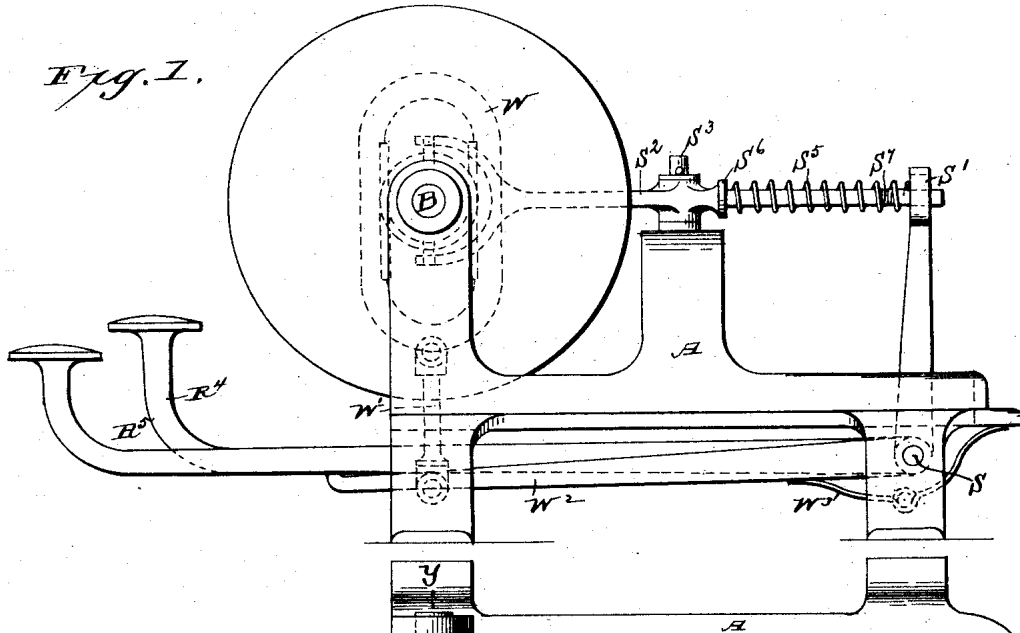
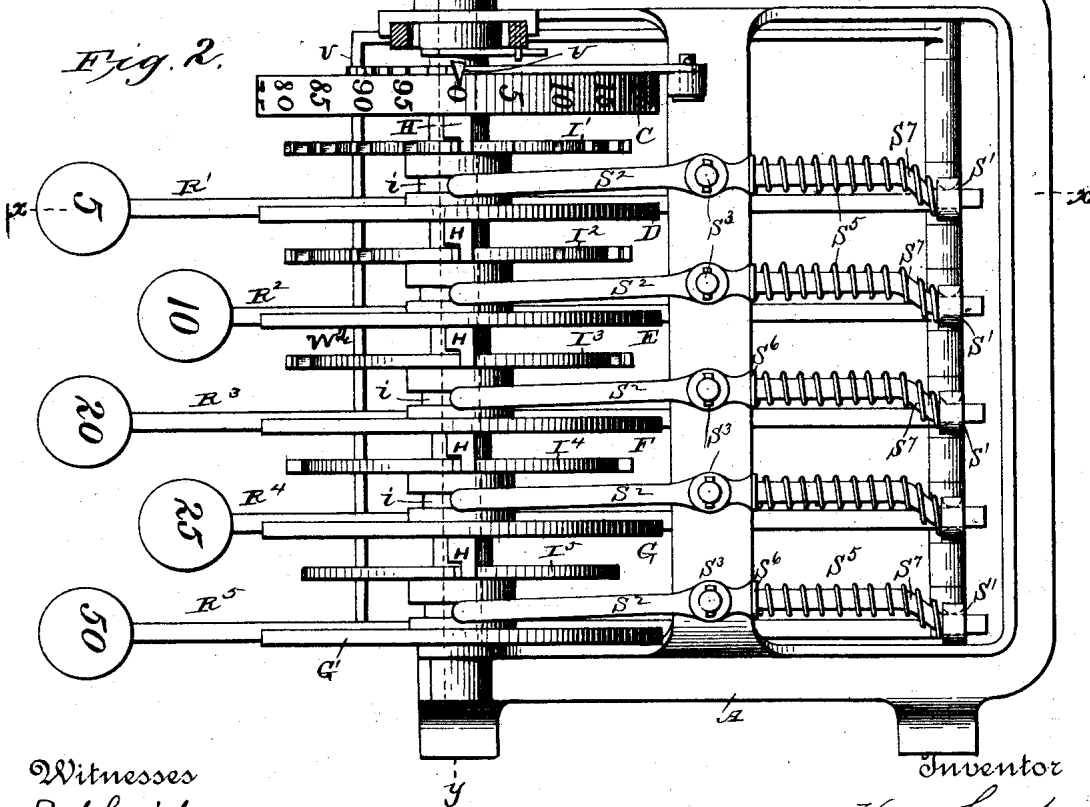

Fig. 2.



Witnesses
E. D. Smith
Alfred Stewart

Inventor
H. Cook

H. COOK.
ADDING MACHINE.

No. 430.001.

Patented June 10, 1890.

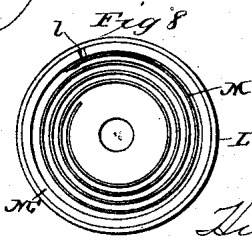
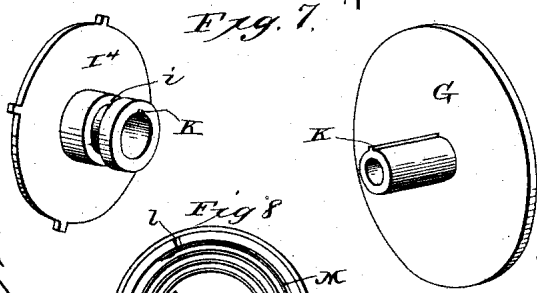
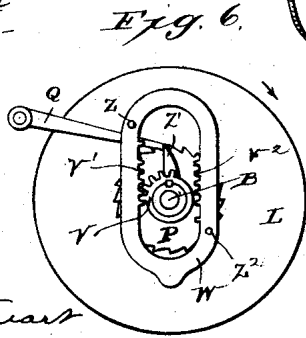
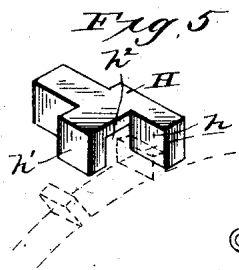
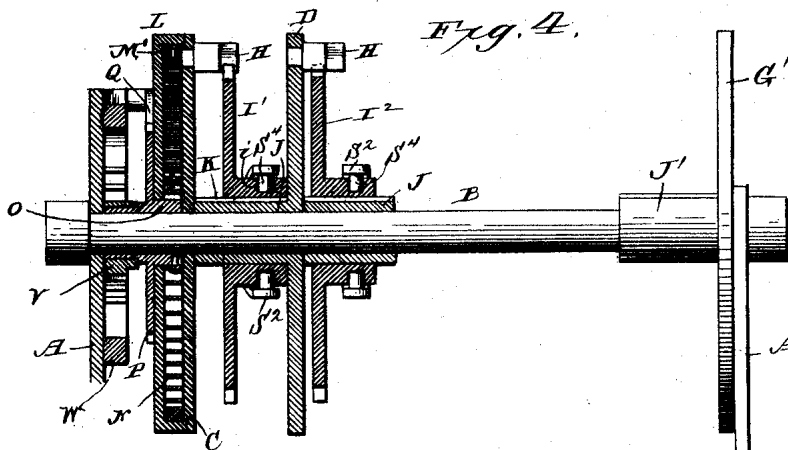
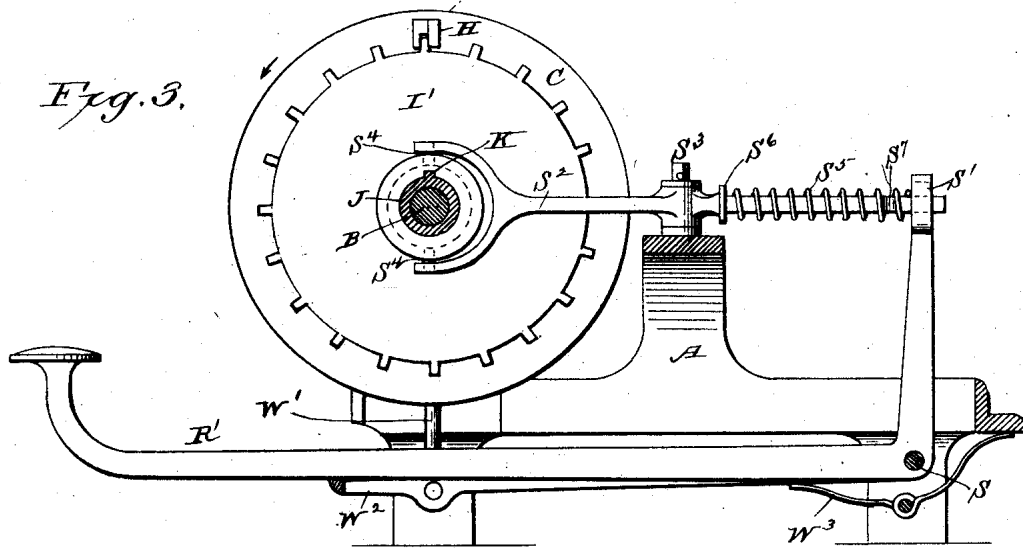

Witnesses
 E. Smith
 Alex. Stearns

Inventor
 H. Cook

UNITED STATES PATENT OFFICE.

HUGO COOK, OF INDIANAPOLIS, INDIANA.

ADDING-MACHINE.

SPECIFICATION forming part of Letters Patent No. 430,001, dated June 10, 1890.

Application filed July 30, 1889. Serial No. 319,231. (No model.)

To all whom it may concern:

Be it known that I, HUGO COOK, of Indianapolis, in the county of Marion and State of Indiana, have invented certain new and useful Improvements in Registering and Adding Machines; and I do hereby declare the following to be a full, clear, and exact description of the same, reference being had to the accompanying drawings, forming a part of this specification, and to the letters of reference marked thereon.

My invention relates particularly to that class of registering and adding machines which are designed for use by store-keepers and others as a means for accurately registering the amounts or values of sales; and it has for its object to simplify and cheapen the construction of devices of this character without impairing their efficiency.

In the accompanying drawings, Figure 1 represents a side elevation of a machine embodying my improvements. Fig. 2 is a top plan view of the same. Fig. 3 is a sectional view taken on the line $x x$ of Fig. 2; Fig. 4, a sectional elevation taken on the line $y y$, Fig. 2. Fig. 5 is a perspective view of one of the escapement-detents and its co-operating detent-arrester or escapement-wheel. Fig. 6 is an end elevation of the mechanism for winding up the motor or prime mover. Fig. 7 represents in perspective one of the escapement-wheels and the detent-support upon which it is designed to be mounted; and Fig. 8, a detail view of the winding-drum, its contained spring, and the interposed friction-ring.

Similar letters of reference in the several figures indicate the same parts.

The letter A represents the frame of the machine in which the various operative parts are mounted. This frame is preferably constructed of metal, and is formed so as to combine lightness with strength.

In the forward part of the frame is arranged a fixed shaft B, and upon this shaft is mounted a series of revoluble detent-supports C, D, E, F, and G. I term these parts "revoluble detent-supports" because each of them is adapted to be revolved under conditions hereinafter explained, and each of them bears and supports a detent H.

Upon the hubs J of the revoluble detent-

supports D, E, F, G and the hub J' of a fixed disk G' are mounted detent-arresters or escapement-wheels I' I² I³ I⁴ I⁵, respectively. I call these parts "detent-arresters" or "escapement-wheels" because they are arranged to arrest and release the detents H when they are moved laterally toward and from the detent-supports, thus constituting in effect escapement movements, as will also be farther on explained.

The revoluble detent-support C is connected to a drum L, which contains a split friction-ring M', to which the outer end of a volute spring N is connected, as shown in Fig. 8, the inner end of said spring being connected to a sleeve O, mounted loosely on the shaft B, and bearing a ratchet-wheel P, with which is adapted to engage a gravitating pawl Q. The tension of the spring N operates, through the friction-ring M', to rotate the drum L, and with it the detent-support C, in the direction indicated by the arrow, Figs. 3 and 6; but said parts are held in check by the engagement of the detent H of said support C with one of the teeth of the escapement-wheel I', the said wheel I' being kept normally stationary by reason of its connection, through the various intermediate detent-supports D E F G, escapement-wheels I² I³, &c., and detents H, with the fixed hub J', as will be readily understood.

By referring to Figs. 2, 4, and 5, and particularly to Fig. 5, it will be seen that each of the detents H is provided with two contacting or engaging faces—that is to say, an outer face h and an inner face h' . It is with the outer face h that the tooth of the escapement-wheel I' is normally engaged; but whenever the said wheel is moved laterally toward the face of the detent-support C its tooth which happens at the time to be engaged passes out of the path of the said outer face h through the slot h^2 , and permits the detent, under the influence of the spring-drum, to be advanced till its inner and forward face h' strikes against the next succeeding tooth of the wheel, and then upon the backward or return movement of said wheel the tooth with which said face h' has engaged slips out of the path of said face through the slot h^2 and into the path of the outer and rearward face h , thus permitting the detent and its support

to further advance till the face *h* comes in contact with said second tooth. From this description it will be seen that in order to advance the detent and its support a distance equal to the distance between any two teeth on the wheel I' the said wheel is required to be first moved laterally toward and then away from the support C, in the course of which movements the face *h* of the detent is first disengaged from the tooth that holds the detent in check. Then the inner and forward face *h'* advances and engages the next succeeding tooth, after which the said face *h'* becomes disengaged from said last-mentioned tooth, whereupon the outer rear face *h* advances, and finally becomes engaged with said tooth. It is necessary that this mode of causing the step-by-step advance of the detent and its support by the shifting of the escapement-wheel should be clearly understood, inasmuch as the other detent-supports D E F G of the series are controlled and advanced in a precisely similar way by the co-operation of the escapement-wheels I², I³, I⁴, and I⁵, with which they are respectively combined.

By reference to Figs. 2, 4, and 7 it will be observed that the hub of each of the escapement-wheels is provided with an annular groove *i*, in which project pins S¹ S¹ on the bifurcated end of a horizontal lever S², which lever is pivoted at S³ and has its shank or inner end passed through a slot or perforation S' in the upper end of a bell-crank key-lever R', such as is shown in Fig. 3. The shank of the lever S² is preferably inclined or slightly curved, as at S⁷, Fig. 2, and about it is coiled a spring S⁵, one end of which bears against a collar S⁶ and the other against the upturned end of the key-lever. Upon the depression of the key-lever which controls the first escapement-wheel I' the upturned slotted end of each lever advances along the curved or angular portion of the shank of the lever S² against the tension of the spring S⁵ thereupon and causes said lever S² to be moved laterally and its outer bifurcated end to shift the escapement-wheel I' toward its co-operating detent-support C, thereby causing the outer engaging face *h* of the detent H to be released and its inner forward face *h'* to advance to the next tooth, while upon the release of the key-lever the spring S⁵ will react, restore the key-lever to its original position, and in so doing cause the bifurcated outer end of the lever S² to slide back the escapement-wheel till it is released from contact with the said face *h'* of the detent and brought into the path of the face *h*, thereby completing the advance of the detent and its support from one tooth to the next, as before described. Each of the several escapement-wheels I² I³ I⁴ I⁵ is connected through similar intervening mechanism with key-levers R² R³ R⁴ R⁵, as shown in Fig. 2. If the key-lever R² is depressed instead of the key-lever R', the escapement-wheel I² will be shifted

first toward and then away from its co-operating detent and detent-support H D, and the said detent and support will be advanced the distance between two teeth on the escapement wheel I². Not only will the detent and detent-support H D be thus advanced by this movement of the escapement-wheel I², but the detent and detent-support H C and their co-operating escapement-wheel I' will also be advanced bodily with them, which is due to the fact that the motion of said parts H D has to be transmitted from the spring-drum through the instrumentality of the said detent and detent-support H C, escapement-wheel I', and the spline-and-groove connection K, as shown clearly in Fig. 4. So in like manner when either of the escapement-wheels I³, I⁴, or I⁵ is operated by its appropriate key the forward motion of its co-operating detent and detent-support is effected through all the preceding detents and detent-supports and escapement-wheels of the series. The hub of the last escapement-wheel I⁵ of the series slides upon the fixed hub or sleeve J', before alluded to. This fixed hub, therefore, performs the important function of serving as the final resistance to the action of the spring-drum or prime mover of the mechanism and operates to hold all the movable parts of the mechanism mounted on the shaft B normally stationary.

I preferably assign to the several key-levers different values, and I provide the escapement-wheel controlled by each with a number of teeth bearing the proper relation thereto. For instance, in the machine here illustrated, I have designated key R' as a "five-cent key," key R² as a "ten-cent key," key R³ as a "twenty-cent key," key R⁴ as a "twenty-five cent key," and key R⁵ as a "fifty-cent key," and I have provided the escapement-wheel I', controlled by the five-cent key, with twenty teeth, so that the distance between each two teeth shall represent the twentieth part of one hundred, or, in other words, the twentieth part of a dollar. So in like manner I have provided the escapement-wheels I² I³ I⁴ I⁵ with ten, five, four, and two teeth, respectively, to correspond with the parts of a dollar which the ten-cent, twenty-cent, twenty-five-cent, and fifty-cent keys represent, respectively.

The periphery of the drum L, which incloses the motor-spring, and to which the first detent and detent-support H C of the series is connected, I divide off into twenty equal divisions corresponding to the number of teeth on the first escapement-wheel I' controlled by the five-cent key, numbering them from 0 to 95, as shown in Fig. 2. It must now be apparent that if the indicator-pointer U (see Fig. 2) stands at 0 and the five-cent key is pressed and released the escapement I' will be operated, so as to cause the detent and detent-support H C and the connected registering-drum to advance the distance between two teeth of said wheel I', or, in other words, one-twentieth of a revolution, and that this

advance will be indicated upon the said registering-drum; furthermore, that if the ten-cent key is pressed and released so as to operate the second escapement-wheel I², which has ten teeth, the detent and detent-support H D, as well as the escapement-wheel I¹, detent and detent-support H C, and the registering-drum, will be caused to advance the distance between two teeth on said wheel I², or, in other words, one-tenth of a revolution, which advance, representing ten cents, will be added to the amount previously registered, and the sum-total—namely, fifteen cents—indicated on the registering-drum. In like manner the pressure and release of the twenty-cent key will cause twenty more to be added to the sum indicated by the registering-drum, and so on, the sum represented by each key being automatically added and indicated on the register as the keys are operated. Should a sale amounting to, say, fifty-five cents be required to be registered, the five and the fifty cent key could be operated either successively or simultaneously with the same result, and it would make no difference if the three keys representing twenty-five, twenty, and ten cents were simultaneously depressed for the purpose of registering the said amount of fifty-five cents, as each would perform its own proper function without being interfered with at all by the others. The reason for this is plain. As each key is operated the registering-drum is released and carried around by the spring through that portion of a revolution which the distance between the teeth controlled by that particular key represents, and the sum of the advances is added together and indicated on the register with accuracy and certainty.

Although it is true that when the escapement-wheel I⁵ is operated by the fifty-cent key so as to release the detent-support G the register will be given a half-revolution, while the release of any other detent by a key of lower denomination will only give less than a half-revolution of the register, it by no means follows that if both the fifty-cent key and some other key of lower denomination are simultaneously operated only the operation of the fifty-cent key will be registered. On the contrary, to the half-revolution of the register given by the fifty-cent key will be added that proportion of a revolution which the key of lower denomination is competent when operated alone to effect, and the sum of both movements will be indicated on the register. The action may be compared with the placing of weights on a pair of scales. The aggregate effect will be the same whether they are added one at a time or put on all together.

In order that the spring M within the drum L may be kept at a sufficient tension to at all times afford motive power to drive the mechanism, I have arranged a winding device adapted upon the operation of each key to wind up the spring. Such winding mechanism

is constructed as follows: Upon the sleeve O, to which the inner end of the spring N is attached, I secure a toothed sector V, as shown in Figs. 4 and 6, and co-operating with this toothed sector is a sliding yoke W, having on its inner vertical portions opposite rows of rack-teeth V¹ V². This yoke W is connected, through a link or other suitable connection W¹, to a vibrating frame W², which is pivoted upon the shaft S and extends across the machine beneath the key-levers thereof, as shown in Figs. 1, 2, and 3. Whenever a key-lever is depressed this vibrating frame W² is likewise depressed against the tension of a spring W³ and draws the yoke W downward, thereby causing the toothed sector V to be rotated by the engagement of the rack-teeth V¹. Before, however, the yoke reaches the extreme of its downward movement, and as the rack-teeth V¹ are about to go out of mesh with the toothed sector, a pin Z upon the yoke strikes an extended cam-surface Z¹, secured to and moving with the toothed sector, thereby carrying around the sector into position to be engaged by the rack-teeth V² on the other side of the yoke, when the latter rises under the influence of the lifting-spring W. As the yoke nears its upward extreme of movement, another pin Z² strikes the cam Z¹ and continues to rotate the toothed sector till it assumes a position ready for engagement with the opposite rack-teeth again on the next downward movement of the yoke. In this way motion is imparted to the winding-sleeve O during both the up and down movements of the yoke, such motion being sufficient to keep this spring at all times properly wound. The lifting-spring W is of course required to be stronger than that of the motor-spring M, in order that it may operate to assist in winding the latter up.

Inasmuch as the motor-spring is partially wound up by the operation of each key and is only unwound to a slight degree by the operation of a key of low denomination, it is clear that unless some provision is made to prevent it the operation of a key of low denomination several times in succession will cause the spring to become so tightly wound as to render the machine inoperative. I have therefore found it desirable to employ the friction-ring M' (see Fig. 8) as the medium of connection between the spring and the drum L. This friction-ring is split, as shown at I, and it is put into the drum L under compression, so that it will tend to bind therein. The end of the spring is connected to the ring at one side of the opening in it, and the tighter the spring is wound up the more the ring is compressed and caused to loosen its hold upon the drum. By this provision overwinding of the spring is effectually prevented.

While I have only shown in the accompanying drawings a register adapted to indicate the addition and registration of sums in multiples of five up to one hundred, it is obvious that by the addition of ordinary multiplying

gearing the revolutions of the register may in turn be recorded, and so on *ad infinitum*, as desired. I make no claim to the use of such multiplying mechanism, and hence have not deemed it necessary to illustrate it.

Having thus described my invention, what I claim as new is—

1. In a registering-machine, the combination, with a revoluble escapement-detent, of a co-operating detent-arrester relatively non-rotatable with respect to the said escapement-detent, but movable laterally in a plane substantially parallel to the axis of motion of the said escapement-detent, substantially as described.

2. In a registering-machine, the combination, with a revoluble escapement-detent, of a laterally-movable and relatively non-rotatable toothed escapement-wheel for co-operating with said detent, substantially as described.

3. In a registering-machine, the combination, with a revoluble detent and a register connected therewith, of a co-operating detent-arrester relatively non-rotatable with respect to the said detent, but movable laterally in a plane substantially parallel to the axis of motion of the said escapement-detent, substantially as described.

4. In a registering-machine, the combination, with a revoluble detent and a register connected therewith, of a laterally-movable and relatively non-rotatable toothed escapement-wheel for co-operating with said detent, substantially as described.

5. In a registering-machine, the combination, with a revoluble registering-wheel carrying an escapement-detent, of a laterally-movable and relatively non-rotatable toothed escapement-wheel co-operating with said detent, substantially as described.

6. In a registering-machine, the combination, with a revoluble escapement-detent and a register connected therewith, of a motor or prime mover for actuating said detent, and a co-operative detent-arrester relatively non-rotatable with respect to the detent, but movable laterally in a plane substantially parallel to the axis of motion of the said escapement-detent, substantially as described.

7. In a registering-machine, the combination, with a revoluble escapement-detent and a register connected therewith, of a motor or prime mover for actuating the detent, a co-operative detent-arrester relatively non-rotatable with respect to the detent, but movable laterally in a plane substantially parallel to the axis of motion of the said detent, and a key for actuating the detent-arrester, substantially as described.

8. In a registering-machine, the combination, with a motor or prime mover, of a series of escapement-detents and revoluble supports therefor, and a series of movable and relatively non-rotatable detent-arresters for co-operating with said detents and each con-

nected to and moving with the next succeeding detent-support, substantially as described.

9. In a registering-machine, the combination, with a motor or prime mover, of a series of escapement-detents and revoluble supports therefor, and a series of relatively non-rotatable detent-arresters for co-operating with said detents and each connected to and moving with the next succeeding detent-support, and a series of keys for actuating the detent-arresters, substantially as described.

10. In a registering-machine, the combination, with a motor or prime mover, of a series of escapement-detents and revoluble supports therefor, and a series of movable though relatively non-rotatable toothed escapement-wheels, each connected to and moving with the next succeeding detent-support, and a series of keys for operating the escapement-wheels, substantially as described.

11. In a registering-machine, the combination, with a motor or prime mover, of a series of escapement-detents and revoluble supports therefor, and a series of laterally movable co-operating escapement-wheels, each connected to and moving with the succeeding detent-support, and a register connected with the first detent-support of the series, substantially as described.

12. In a registering-machine, the combination, with a prime mover, of a series of escapement-detents and revoluble supports therefor, a series of movable and relatively non-rotatable toothed escapement-wheels co-operating with said detents, each connected to and moving with the next succeeding detent-support, and each having teeth differing in numbers from those on the other escapement-wheels, substantially as described.

13. In a registering-machine, the combination, with a prime mover, of a series of escapement-detents and revoluble supports therefor, a series of movable and relatively non-rotatable toothed escapement-wheels, each connected to and moving with the next succeeding detent-support, and each having teeth constituting a multiple of a given number, substantially as described.

14. In a registering-machine, the combination, with a prime mover, of a series of escapement-detents and revoluble supports therefor, a series of co-operating movable and relatively non-rotatable detent-arresters, each connected to and moving with the next succeeding detent-support, a series of actuating-keys, one for each detent-arrester, and a register for registering the movements of each detent, substantially as described.

15. In a registering-machine, the combination, with a prime mover, of a series of escapement-detents and revoluble supports therefor, a series of co-operating movable and relatively non-rotatable toothed detent-arresters, each connected to and moving with the next succeeding detent-support, a series of actuating-keys, one for each detent-ar-

rester, and a register for registering one or more or all of the detents when actuated by the movements of the finger-keys, substantially as described.

5 16. In a registering-machine such as described, the combination, with the motor or prime mover, of the series of escapement-detents and revoluble supports therefor, the series of laterally-movable toothed escapement-wheels mounted upon so as to rotate with the
10 detent-supports, and the fixed sleeve or hub upon which the last escapement-wheel in the series is mounted, substantially as described.

15 17. In a registering-machine such as described, the combination, with the motor or prime mover, of the series of escapement-detents and revoluble supports therefor, the series of laterally-movable toothed escapement-wheels mounted upon so as to rotate with the
20 detent-supports, the fixed sleeve or hub upon which the last escapement-wheel in the series is mounted, and the keys and intermediate mechanism by which the escapement-wheels are shifted, substantially as described.

25 18. In a registering-machine, the combination, with a motor or prime mover, of a series of detents and revoluble supports therefor, a co-operating series of movable though relatively non-rotatable detent-arresters, keys
30 and intermediate mechanism for shifting the detent-arresters into and out of co-operation with their respective detents, and mechanism connected with the key for restoring the power of the motor, substantially as described.
35

19. In a registering-machine, the combination, with a spring-motor or prime mover, of a series of detents and revoluble supports therefor, a corresponding series of movable
40 though relatively non-rotatable detent-arresters, keys and intermediate mechanism for shifting the detent-arresters, and a motor-winding mechanism operated by the operation of any key, substantially as described.

45 20. In a registering-machine such as described, the combination, with the revoluble detent-supports and their detents, of the toothed escapement-wheels connected by the spline-and-groove connections to the hubs of the
50 detent-supports, and the keys and intermediate mechanism for shifting the escapement-wheels on the detent-supports, substantially as described.

55 21. In a registering-machine such as described, the combination of the revoluble detent-supports and their detents, the toothed escapement-wheels, the vibratory levers for

shifting the escapement-wheels, and the key-levers and springs for actuating said vibratory levers, substantially as described.

22. The combination, with the revoluble detent-support, of the detent having the two contact-faces in different planes, one in advance of the other and the co-operating toothed
60 escapement-wheel having a lateral motion to and from the detent-support in a plane substantially parallel to the axis of said detent-support, substantially as described. 65

23. The combination, with the toothed escapement-wheel, of the revoluble detent-support having the detent provided with the contact-faces h h' , and the slot for the passage of the tooth of the escapement-wheel, substantially as described. 70

24. The combination, with the spring of the motor, of the sleeve to which the end of said spring is connected, the toothed sector of the cam connected therewith, and the reciprocating yoke provided with the teeth for engaging the toothed sector, and with the pins
80 or stops for operating upon the cam, substantially as and for the purpose specified.

25. The combination, with the key-levers, of the vibratory spring-pressed frame beneath the same, the reciprocating yoke connected
85 to said vibratory frame and having the teeth and pins, and the toothed segment and cam on the sleeve of the motor-winding mechanism, substantially as described.

26. In a registering-machine, the combination, with a spring-motor or prime mover, of a series of detents and revoluble supports therefor, a corresponding series of movable
90 though relatively non-rotatable detent-arresters, keys and intermediate mechanism for shifting the detent-arresters, a motor-winding mechanism operated by the operation of any key, and a friction appliance for preventing
95 overwinding of the spring of the motor, substantially as described. 100

27. The combination, with a detent having two contact-faces in different planes, of a co-operating toothed escapement-wheel movable toward and from said detent and adapted to engage alternately the two contact-faces there-
105 of, substantially as described.

In testimony whereof I have hereunto set my hand in the presence of two subscribing witnesses.

HUGO COOK.

Witnesses:

T. R. BELL,
JAMES T. WRIGHT.