

(No Model.)

3 Sheets—Sheet 1.

M. N. LOVELL.
CASH REGISTER AND INDICATOR.

No. 445,959.

Patented Feb. 3, 1891.

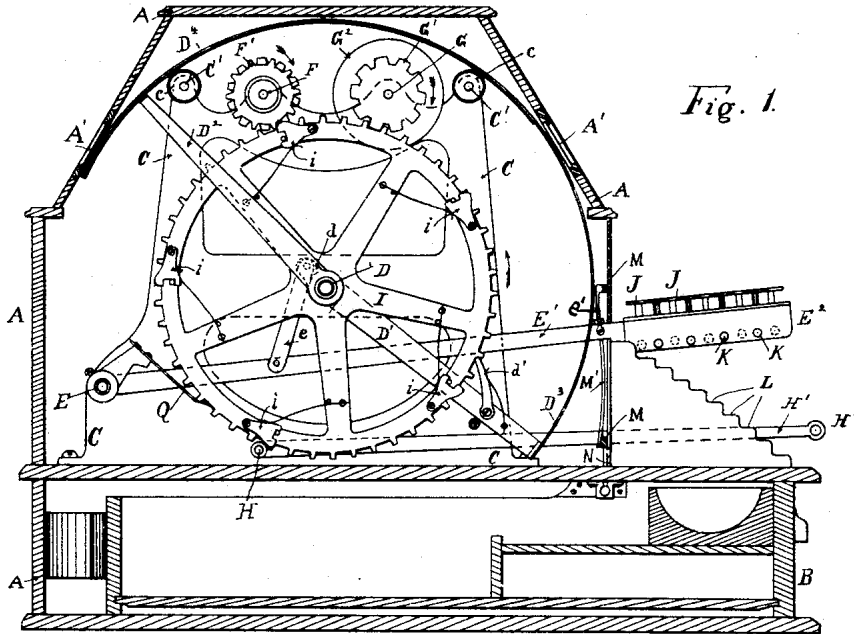

Fig. 1.

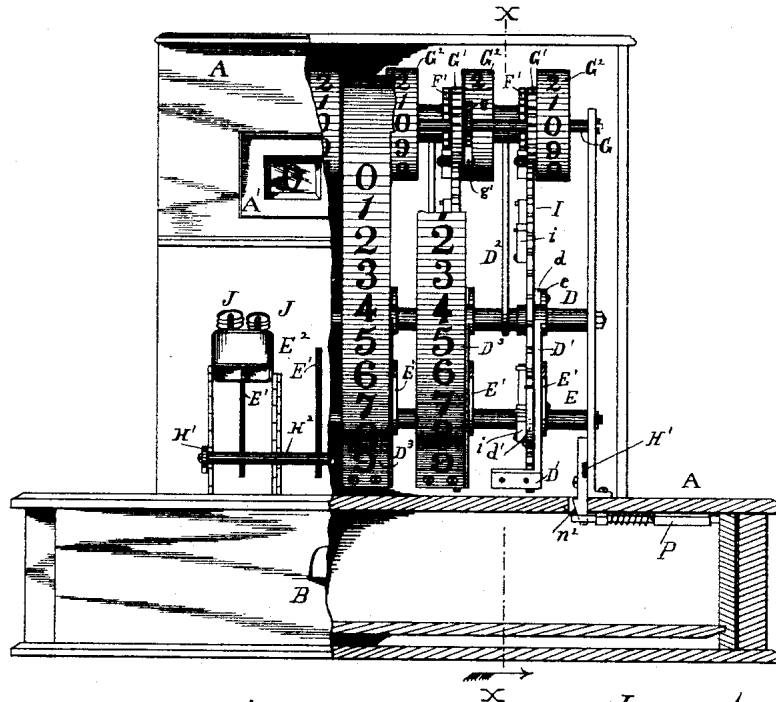

Fig. 2.

Witnesses.

Wm. D. Johnson
J. D. Robbins

Inventor.

Melvin N. Lovell
by his attys
Hallock & Haller

M. N. LOVELL.
CASH REGISTER AND INDICATOR.

No. 445,959.

Patented Feb. 3, 1891.

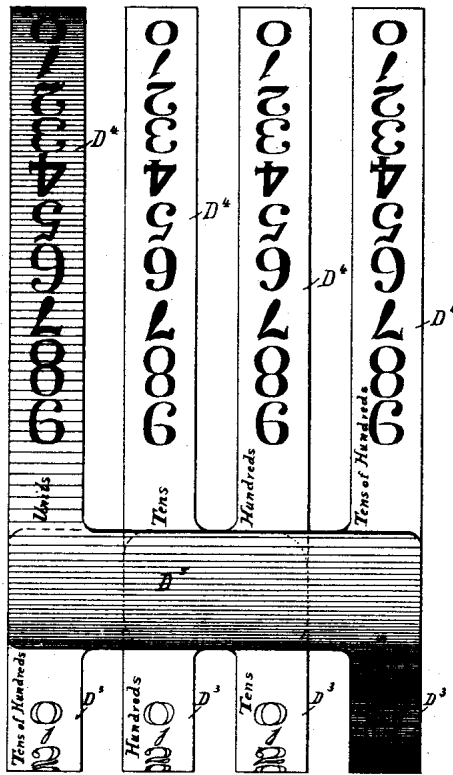

Fig. 4.

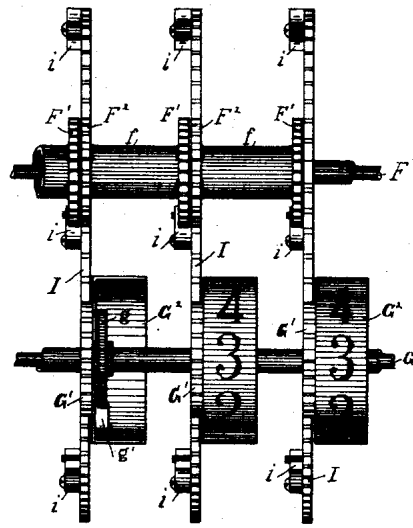

Fig. 3.

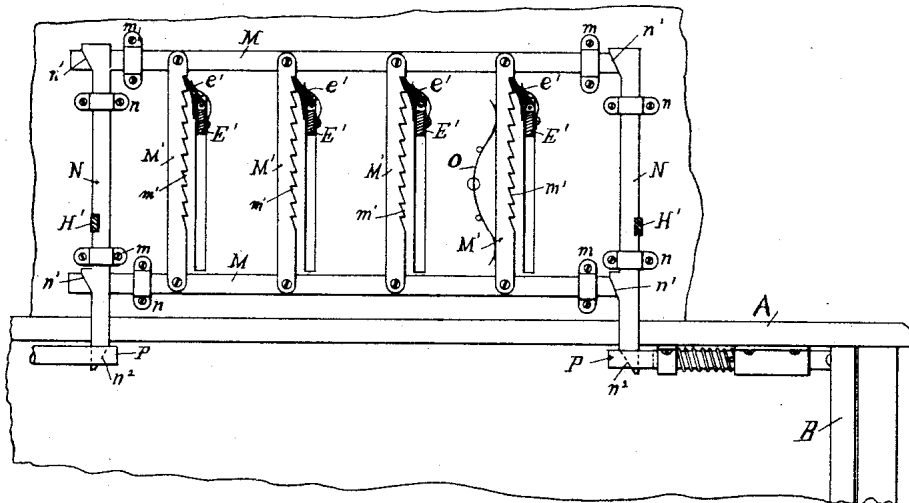

Fig. 5.

Witnesses.
[Signature]
 S. D. Robbins

Inventor.
 Melvin N. Lovell
 by his attys.
 Hallock & Hallack

M. N. LOVELL.
CASH REGISTER AND INDICATOR.

No. 445,959.

Patented Feb. 3, 1891.

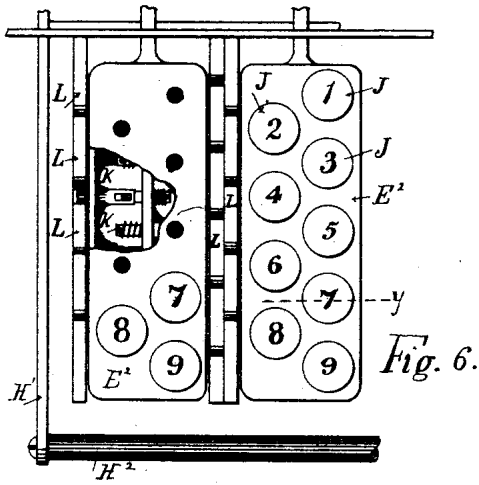

Fig. 9.

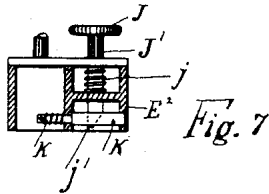
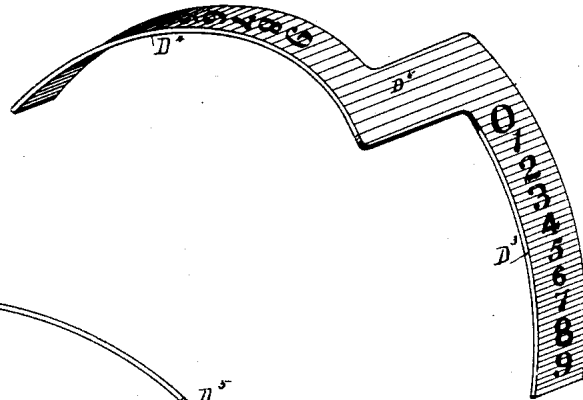
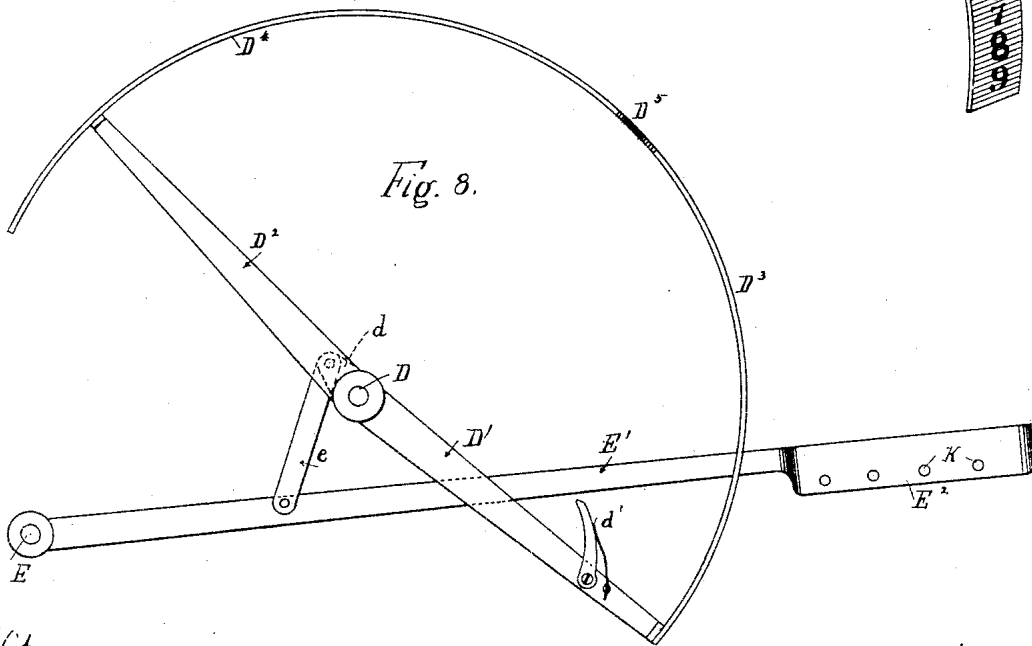

Fig. 8.



Witnesses.
Chas. S. Peckham
J. H. Robbins

Inventor.
Melvin N. Lovell
 by his attorney
Hallcock & Hallcock

UNITED STATES PATENT OFFICE.

MELVIN N. LOVELL, OF ERIE, PENNSYLVANIA, ASSIGNOR TO THE LOVELL MANUFACTURING COMPANY, LIMITED, OF SAME PLACE.

CASH REGISTER AND INDICATOR.

SPECIFICATION forming part of Letters Patent No. 445,959, dated February 3, 1891.

Application filed March 23, 1889. Serial No. 305,055. (No model.)

To all whom it may concern:

Be it known that I, MELVIN N. LOVELL, a citizen of the United States, residing at Erie, in the county of Erie and State of Pennsylvania, have invented certain new and useful Improvements in Cash Indicating, Registering, and Accounting Machines; and I do hereby declare the following to be a full, clear, and exact description of the invention, such as will enable others skilled in the art to which it appertains to make and use the same.

This invention relates to that class of machines which are commonly called "cash indicating, registering, and accounting machines;" and it consists in certain improvements in the construction and operation of the same, as will be hereinafter set forth and explained, and pointed out in the claims.

My invention is illustrated in the accompanying drawings, in which—

Figure 1 is a transverse vertical section view taken on the line xx in Fig. 2. Fig. 2 is a front elevation view with parts broken out to show internal construction. Fig. 3 is a top or plan view of part of the registering and accounting mechanism. Fig. 4 is a diagram view of the indicating mechanism. Fig. 5 is a front elevation view of the retaining and releasing mechanism, as will be more fully explained herein. Fig. 6 is a top view of a part of the key-board. Fig. 7 shows a detail of construction of one of the actuating-levers, and is a section on the line yy in Fig. 6. Fig. 8 is a side elevation of one of the actuating-levers and one of the indicators. Fig. 9 is a perspective view of one of the indicators.

The construction and operation of my device are as follows:

A marks an inclosing case, which has within its base a drawer B. In its upper portion is contained the mechanism, and at one side is a key-board.

A' A' are openings in the side of the case, through which can be seen the indicators and the figures marked thereon.

C marks a metallic frame-work, in which is supported the mechanism hereinafter described.

D is a central fixed shaft supported by the

frame-work C, and on it are loosely journaled certain cog-wheels I and arms D'. The number of these wheels and arms is optional, or rather it is regulated by the amount the machine is designed to indicate. I show four sets of these parts, and the machine illustrated is intended to indicate and register sums within thousands; but if a machine were to register tens of thousands, then it would have five sets of wheels, arms, &c.

On a fixed shaft E at the back of the frame-work C are pivoted as many levers E' as there are wheels I and arms D' on the shaft D. Each lever E' is connected with its companion arm D' by a link e , which connects with the short end d of the arm D', and each arm D' is provided with a pawl d' , which engages with its companion wheel I. A downward movement of the lever E' will cause an upward movement of the long end of the arm D', and the pawl d' will cause a movement of the wheel I to the extent of the arc of movement of the pawl d' .

The extent of movement of the lever E' is regulated by peculiar mechanism as follows: On the end of each lever E' is a key-box E², in which are nine (9) keys J. When the lever is to be depressed, the operator will touch one of these keys J, according to the amount he desires to record and indicate. Each of the keys J is marked with a numeral, as shown in Fig. 6. When one of these keys J is pushed down upon, it yields before the lever carrying it yields, and as it yields it throws out from the side of the key-box a catch K. A continued pressure on the key causes the lever E' to be depressed.

On the frame at the sides of the key-box E² there are stepped frame pieces or plates L, which will come in contact with the catch K, which has been pushed out from the side of the key-box by the key J and arrest the action of the lever E'. Thus if a key J having thereon the numeral 3 is pressed upon the lever E' can only be depressed until the catch K, actuated by the key just named, comes in contact with the proper step on one of the plates L, and if a key J having thereon the numeral 9 is pressed then the lever can be depressed until the catch moved by that key

comes in contact with the lowest step of the plates L. It will now be understood that the degree of movement of the lever E' is regulated by the key that is pressed upon to actuate the lever E', and the degree of movement of the lever E' regulates the degree of movement of the wheel I, which is moved by that lever. Thus if the lever E' is moved down by pressing the key marked with the numeral 3 it will go down until stopped by the third step of the plates L, or, let us say, three spaces, and it will move the gear-wheel I three cogs, and if it is depressed by pressing key 9 then it will move the wheel I nine cogs.

The means by which the key J extends a catch at the side of the key-box E² is a matter of choice or selection of many devices which will quickly suggest themselves to a mechanic. In Figs. 6 and 7 I show an operative construction for this purpose. The key J has a stem J', on which is a reacting spring j, and at its end there is a bevel j', which fits in a slot in a bolt or catch K, which has a reacting spring k.

The indicating appliance is as follows: Attached to each arm D' is a curved narrow plate D³, the curve of which has the shaft D for its center. On this plate are marked the numerals 0, 1, 2, &c., to 9, beginning at the top and reading down. (See Fig. 2.) As the lever E' is depressed, the arm D' is moved up and the indicator-plate D³ is moved past the opening A' in the case. If the lever E' is depressed by pressing on the key 3, the lever is moved down three spaces and the arm D' is moved up proportionately, and so the number 3 is exposed at the opening A' at the front of the machine above the keys.

In order to exhibit numerals at the opening A' at the back of the machine simultaneously with those at the front of the machine and have them read from the left to the right, I mount similar plates D⁴ on like arms D² and connect the plates D³ and D⁴ together by webs or plates D⁵. This is clearly shown in Figs. 9 and 4. To aid in supporting these indicators, I put rollers c on the tie-rods C' of the frame-work, as seen clearly in Fig. 1. It will be seen that in effect these indicators are two arcs or circles connected by horizontal bands or webs. One arc is at one side of the machine and the other at the other, and one is at the right of the center of the machine and the other at the left, calling the key-board the front of the machine, and the numerals on one arc read from the top to the bottom and on the other from the bottom to the top. When, for example, the numeral 3 is displayed at the units place at the front of the machine, it is also displayed at the units place at the back of the machine, so that to a person standing at the back of the machine and facing the operator, who is at the front of the machine, the numerals will read from left to right. When a lever is depressed, it should be retained in such position until it is desired to release it. The means by which I effect this

result are as follows: Immediately back of the key-board and just inside of the case is a rack consisting of horizontal bars M and vertical bars M'. (See Fig. 5.) The horizontal bars M are held in guides m, so that they can move easily horizontally. The vertical bars M' stand by the side of the levers E', and they have ratchets on their sides with which pawls e' on the levers E' engage. Whenever a lever E' is depressed, the pawl e' will catch on the ratchet m' and hold the lever down. At each end of the rack just described there are vertically-movable bars N, which are guided in loops n. On the sides of these bars N there are inclines n', which bear upon proper faces on the bars M. By drawing down the bars N the bars M will be moved horizontally, and this will carry the ratchet-bars M' away from the pawls e', and thus leave the levers E' free to react. On each side of the key-board there are levers H', which are pivoted at H, and they are tied together by a bar H², which lies along the front of the machine. (See Figs. 1 and 2.) The levers H' are connected with the vertical bars N, as seen at H' in Fig. 5. Whenever the operator wishes to release the depressed keys, he will press down on the bar H². On the bottom of the bars N there are other inclines n², which act upon spring-bolts P to draw them back. These spring-bolts hold the drawer B from being drawn out. Therefore when it is desired to open the drawer the operator must depress the levers H'.

The registering and accounting mechanism is in many respects the same as that shown in Letters Patent of the United States No. 41,898, dated March 15, 1864, issued to Joseph B. Alexander for improvement in calculating-machines, and will therefore not be broadly claimed by me of itself. Its construction and operation are as follows: The wheels I have cogs in sets of ten—that is to say, they have twenty, thirty, forty, or fifty cogs, as desired. As shown, they have fifty; but I think wheels of thirty cogs would be equally desirable, and perhaps more so. Opposite each tenth cog on the wheel I there are dogs z, which act upon the cogs of a gear F', which is loose on the shaft F. This cog-gear F' is connected with a gear F² by a sleeve f, and this last-named gear F² meshes with the next adjoining wheel I. Whenever a wheel I is moved ten cogs, the next adjoining wheel I to the left is moved one cog through the action of the dogs z and gears F' and F². Now let the wheel I at the right of the mechanism represent units, the next to the left tens, the next hundreds, and so on. When the units-wheel has been moved ten spaces, the tens-wheel will be moved one space, and when the tens has been moved ten spaces the hundreds will be moved one space, and so on. On the shaft G there are loosely journaled gear-wheels G', which have ten teeth or cogs, and they carry drums G², on which are marked the numerals. These drums may be loosely journaled on the hubs of the gears G' or on the shaft G and

have motion communicated to them from the gears G' by a pawl and ratchet g g' or other clutching device. By this means the drums may be rotated backward by the hand to set them all to the zero-line before starting the mechanism. The gears G' and drums G^2 are for registering the number of spaces that the wheels I may be moved. Before starting the machine each wheel I should be set with one of the dogs i' just escaped past the gear F' and all the drums G^2 with their naughts at the reading-line. The machine being thus set, the case should be closed and parts be left undisturbed, except as operated by the keys.

The operation of the machine will be as follows: Let us suppose that the operator wishes to record a sale amounting to \$12.56. He may do it by pressing key 1 on the left-hand lever, key 2 on the next lever to the right, key 5 on the next lever to the right, and key 6 on the right-hand lever, or he may work from right to left, or he may follow no successive action, the result will be the same — to wit, the indicators will display at the openings A' in the case the figures 1 2 5 6, and on the drums inside the figures 1 2 5 6 will be on the reading-line. The operator will then depress the bar II^2 , which will release the levers E' , and they will all resume their normal position, the indicators will all show naughts at the openings A' ; but the drums G^2 in the case will stand, as above stated, with the figures 1 2 5 6 in line. If the next sale to be recorded should be \$13.64, the drums G^2 would be moved so as to read 2 6 2 0, which is the sum of 1 2 5 6 and 1 3 6 4, while the indicators would show at the openings A' the figures 1 3 6 4, the amount of the last sale recorded.

The means for reacting the levers E' and the indicators are not shown, as they may be greatly varied, and will not be claimed as forming any part of the invention; but they will probably be springs properly applied to the levers E' or the arms D' . To prevent the wheels I being thrown too far over by the action of the levers, I employ a brake, which consists of the spring Q , which has its free end in contact with the cogs of the wheels, as seen in Fig. 1. It may be well to observe that of the keys J on the levers the one marked 9, which is the last one at the outer end of the key-box E^2 , need have no catch-action connected with it, for the last catch of the series may be fixed. In fact, the end of the key-box itself may serve as a stop. Therefore, when in the following claims these keys and catches are referred to as having mechanical action of any kind this exception should be assumed as reserved. I do not desire to be limited to the use of the stepped plates L as an essential element of the construction, although they are probably the most convenient appliance for the purpose.

What I claim as new is—

1. In a machine for the purposes mentioned,

the combination of a series of setting-levers, one of which is to be used for indicating units, the adjoining lever for tens, the next lever for hundreds, and so on throughout the series, a series of nine keys carried on each of said levers, which are marked consecutively with the nine digits, each of which keys will effect a limitation of the movements of said lever according in degree to the digit on the key used to depress said lever, and an indicator moved by each of said levers, which displays any of the nine digits according to the degree of movement of the lever by which it is actuated.

2. In a machine for the purposes mentioned, the combination of two series of indicator-plates arranged to face from opposite sides of the machine, each of which plates has marked thereon the numerals in successive order, the plates of each series being intended to designate units, tens, hundreds, &c., respectively, in successive order from right to left, as viewed by observers on opposite sides of the machine, and connections connecting the plates of one series with those of like designation in the other series, so that a movement of a given plate of one series will cause the like plate in the other series to move correspondingly, whereby as the plates of one series are moved to indicate a given amount the plates of the other series will be moved to indicate the same amount in like manner.

3. In a machine for the purposes mentioned, the combination of a series of setting-levers, one of which represents units, one tens, another hundreds, and so on throughout the series, a series of nine keys carried on each of said levers, which are marked consecutively with the nine digits, each of which keys will effect a limitation of the movement of said lever according in degree to the digit on the key used to depress said lever, an indicator moved by each of said levers, which displays any of the nine digits according to the degree of movement of the lever by which it is actuated, a pawl-and-ratchet attachment for retaining each of said levers at any degree of depression, and a releasing mechanism for releasing all of said levers simultaneously from the engagement of said retaining attachment.

4. In a machine for the purposes mentioned, the combination of a series of setting-levers which represent, respectively, units, tens, hundreds, &c., a series of keys carried on each of said levers, which represent the digits, each of which keys will effect a limitation of the movement of its lever according to the digit represented thereby, an indicator moved by each of said levers, which displays any of the digits represented by said keys according to the degree of movement of the lever by which it is actuated, a pawl-and-ratchet attachment for retaining each of said levers at any degree of depression, a releasing mechanism for releasing all of said levers simultaneously from the engagement of said retaining attachment,

a drawer, a catch for retaining said drawer, and mechanism for releasing said catch which is moved by the mechanism which releases the said setting-levers.

5 5. In a machine for the purposes mentioned, the combination of two series of indicators, one on each side of the machine, each indi-
 10 cator of each series being intended to indicate units, tens, or hundreds, and so on, according to its position relatively in the series, the ar-
 rangement being such that sums indicated on either series shall read properly to an ob-
 15 server facing the same, connections so connecting the indicators of one series with those of the other of like designation that like indicators in both series will move correspond-
 20 ingly and simultaneously, and a series of setting-levers, each of which operates one of the said connected sets of indicators.

20 6. In a machine for the purposes mentioned, the combination of two series of indicators, one on each side of the machine, each indi-
 25 cator of each series being marked with the numerals in successive order, the numeral displayed by it depending on the degree of
 movement which may be imparted to the indicator, each of which indicators also being
 30 intended to indicate units, or tens, or hundreds, and so on, according to the position relatively in the series, the arrangement be-
 ing such that sums indicated on either series shall read properly to an observer facing the
 35 same, connections so connecting the indicators of one series with those of like designation in the other series that like indicators in
 both series will move correspondingly and simultaneously, setting-levers for moving each

of the thus connected sets of indicators, and a series of keys and catches on each lever for limiting its degree of movement. 40

7. In a machine for the purposes mentioned, the combination of a series of setting-levers, one of which is to be used for indicating
 45 units, the adjoining lever for tens, the next lever for hundreds, and so on, a series of nine keys carried on each of said levers, which are
 marked consecutively with nine digits, each of which keys will effect a limitation of the
 50 movement of said lever according in degree to the digit on the key used to depress said lever, an indicator moved by each of said le-
 vers, which displays any of the nine digits according to the degrees of movement of the lever by which it is actuated, a series of reg-
 55 istering-wheels which are operated through the action of said indicators, and a series of carrying-gears, each of which effects, a one-
 degree movement of the next higher register-
 ing-wheel for every ten degrees of movement of its actuating-gear. 60

8. In a machine for the purposes mentioned, the combination, with the setting-lever E',
 65 having means for limiting the movement gradationally, of a rocking indicator consisting of the curved plates D³ and D⁴, connected together by the web D⁵, substantially as and
 for the purposes set forth.

In testimony whereof I affix my signature in presence of two witnesses.

MELVIN N. LOVELL.

Witnesses:

JNO. K. HALLOCK,
 WM. P. HAYES.