

(No Model.)

2 Sheets—Sheet 1.

C. H. WEBB.
 ADDING MACHINE.

No. 465,120.

Patented Dec. 15, 1891.

Fig. 1.

Fig. 2.

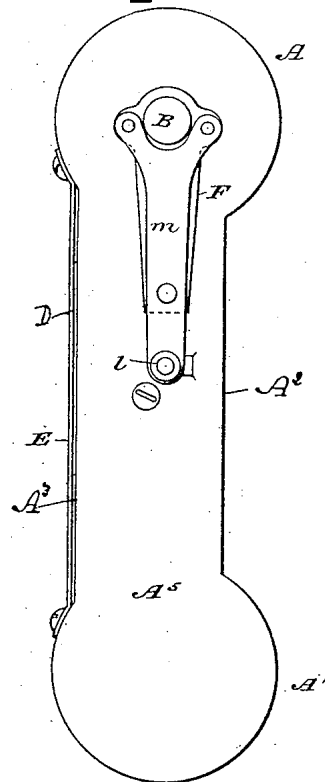
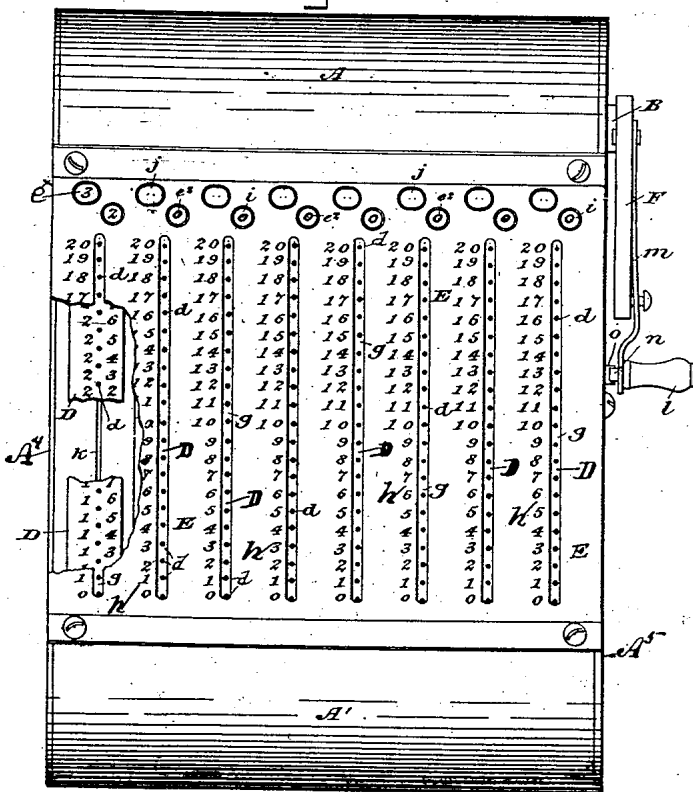

Fig. 4.

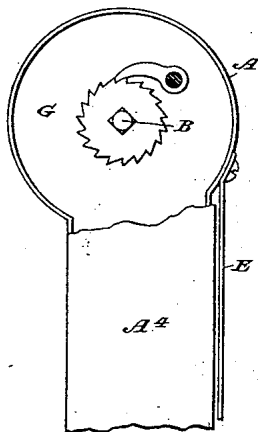
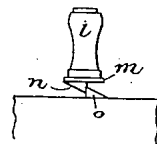

Fig. 7.



WITNESSES:

E. B. Bolton
W. Caspinger

INVENTOR:

Charles H. Webb

By *Harry Comets*
 Attorney.

(No Model.)

2 Sheets—Sheet 2.

C. H. WEBB.
ADDING MACHINE.

No. 465,120.

Patented Dec. 15, 1891.

Fig. 3.

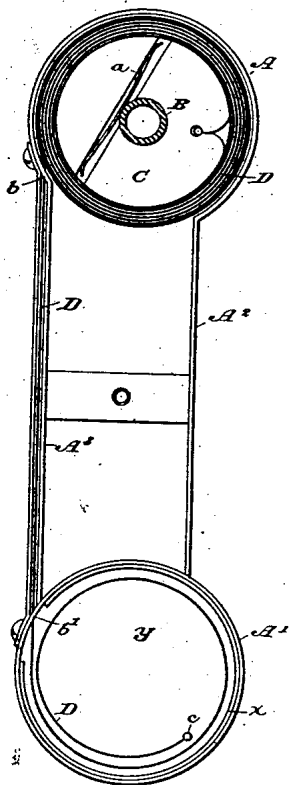

Fig. 5.

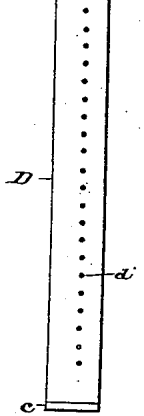
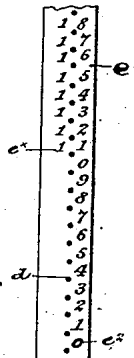
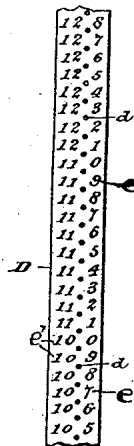
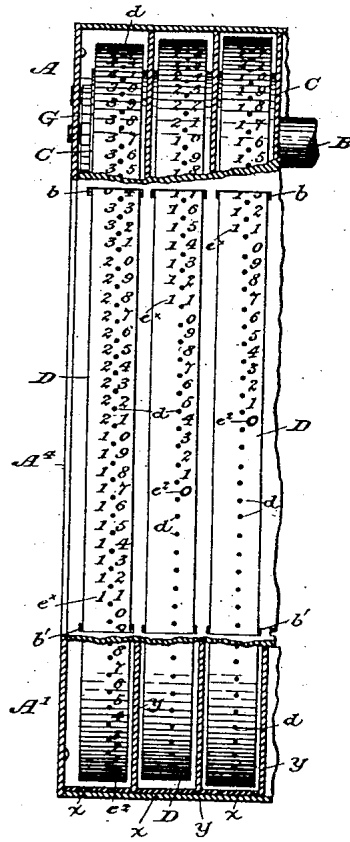

Fig. 6.



WITNESSES:

E. B. Bolton
J. H. Carlinger.

INVENTOR:

Charles H. Webb

Henry Connel
Attorney.

By

UNITED STATES PATENT OFFICE.

CHARLES HENRY WEBB, OF NEW YORK, N. Y.

ADDING-MACHINE

SPECIFICATION forming part of Letters Patent No. 465,120, dated December 15, 1891.

Application filed December 23, 1886. Serial No. 222,343. (No model.) Patented in England June 25, 1888, No. 9,269.

To all whom it may concern:

Be it known that I, CHARLES HENRY WEBB, a citizen of the United States, and a resident of the city, county, and State of New York, have invented certain new and useful Improvements in Adding-Machines, (for which I have received a patent in Great Britain, No. 9,269, dated June 25, 1888,) of which the following is a specification.

My invention relates to machines for adding together numbers, whereby the mental drudgery usually attendant upon such operations is avoided.

So far as relates to its principle of operation, the main characteristic of my machine is the entire independency of the devices for adding the several columns of figures, designated in the decimal system of notation as "units," "tens," "hundreds," &c. In all machines of this class with which I am familiar there is a dependency of the several adding mechanisms, whereby the "carries," so called, are made—that is to say, in the decimal system the tens must be carried to the next column to the left, and in adding fractions, as in currency, the whole numbers must be so carried. This has been effected heretofore by some connecting mechanism or dependent mechanism which I do not employ. In my machine the movable part which bears the numerals destined to form the partial sum also bears the carry-numerals, and these latter are designated or brought into view by the movement of said part in adding.

So far as relates to the mechanical construction of my machine the main characteristic is this: that it is composed, as a whole, of a number of mechanisms—any number may be embodied in one machine—each of which is actuated and operates entirely independent of all the others. For convenience I may call each of these an "adding mechanism."

My construction enables me to add the numerals in a column in any succession I choose. For example, I may add them together crosswise, from right to left or from left to right, or I may add them vertically in the usual way. The carries will then appear at the proper apertures, and these may then be added to complete the sum.

My object has been to construct the machine in the simplest manner possible, in or-

der to avoid too easy derangement of the parts and to secure economy in the manufacture.

My invention will be hereinafter fully described, and its novel features carefully defined in the claims.

In the drawings, which serve to illustrate my invention, Figure 1 is a front elevation of my improved adding-machine in its approved form. In this view a part of the face-plate is broken away at the left side. Fig. 2 is a side elevation of the machine, showing the right-hand side as the machine is seen in Fig. 1. Fig. 3 is a view of the same side of the machine as that seen in Fig. 2, but with the crank and side plate removed to show the interior. Fig. 4 is a fragmentary view of the side opposite to that seen in Figs. 2 and 3 with a part of the side plate broken away to disclose the ratchet mechanism. Fig. 5 shows the adding-ribbon or parts of same, detached. Fig. 6 is a fragmentary front view of the machine with the slotted face-plate removed and the casing broken away to show the ribbon-cells. Fig. 7 is a detached detail view that will be herein after described.

Premising that the form, mode of construction, and material of the casing of my machine may be of any suitable kind or character, I will describe said casing as shown constructed in the drawings. This casing is usually constructed of sheet metal and comprises two parti-cylinders A and A', connected by a back plate A² and a front plate A³ and two side plates A⁴ and A⁵, the latter of which is usually made removable. The parti-cylinders A A' are partitioned off to form cells to receive the adding-ribbons.

In the machine as seen in Fig. 1 eight distinct adding mechanisms, all alike in construction, are embodied. These will serve to add up eight vertical columns of figures, or, in decimal notation, tens of millions. On a shaft B, which is rotatively mounted in the parti-cylinder A, are frictionally mounted ribbon reels or drums C, which I prefer to make of wood. These are all alike, and one is clearly shown in Fig. 3. The shaft B, usually construct of a metal tube for the sake of lightness, and in order to mount the drum C frictionally thereon I fix a leaf-spring *a* in a kerf cut in the end of the drum, so as to in-

55

60

65

70

75

80

85

90

95

100

intersect the hole in the center of the drum through which the shaft passes. This spring a presses constantly and elastically on the shaft.

5 On each drum C is wound an adding-ribbon D, all of which ribbons may for simplicity be exactly alike. The peculiar features, numbering, &c., of these ribbons will be hereinafter more minutely described.
 10 Each ribbon is led from its reel or drum C through a slot b , (seen best in Fig. 6,) formed in the wall of the parti-cylinder A, just above the depressed junction of cylinder A with the front plate A^3 . Thence the ribbon is led
 15 down over said front plate A^3 to and through a slot b' in the parti-cylinder A' and into the receiving-cell in the same. After being once placed in position the end of the ribbon has
 20 an enlargement c , Figs. 3 and 5, formed on its free end to prevent said end from passing back through the slot b' when the ribbon is wound up on its drum or reel. The ribbon D is perfectly flexible, but not limp. It is
 25 made quite thin, and in it, arranged in a longitudinal row, are formed small holes or perforations d , and on each side of said row of holes is a row of figures or numbers e and e^x .
 30 The row e at the right hand are the numbers that appear in the sum after the addition is made. The row e^x at the left hand are the carries or tens or whole numbers, as the case may be. The peculiar respective arrangement of these numbers and the manner in
 35 which they come into play will be hereinafter explained.

When the ribbons are all in place, extending down over the front plate A^3 , they are covered by a face-plate E, usually secured to the casing of the machine by screws. This
 40 face-plate stands just high enough above the front plate A^3 to leave room for the ribbons D to play freely, and in it are formed slots g , one for each ribbon, and in position to expose the rows of perforations d in same.

45 Along the margin of each slot g and spaced in the same manner as the perforations in the ribbon is a row of numerals h , which begins with a cipher at the bottom of the slot and runs up to any desired number, in the present case 20, but it need only run up to 9.
 50 These numerals form the adding-index and their number need only be limited by the length of the machine. In the present case as many as twenty may be added at one operation.

55 In the face-plate E, over the rows of numerals e on the ribbons, are formed apertures i , each large enough to exhibit one numeral. This row of apertures i exhibits the numerals forming the sum after each adding operation.
 60

Above the apertures i a distance equal to the distance apart of the numerals on the ribbon are formed apertures j , which are in
 65 position to expose or exhibit the numerals in the row e^x on the ribbon. These apertures exhibit the numerals to be carried, and as it

will sometimes happen that a sum too great to be expressed by one numeral, as 10 11 12 &c., must be carried, I usually make the aperture j wide enough to show two numerals. I arrange the apertures i and j above the slots g for convenience only. They might as well be placed below. These apertures i and j are merely designators for the purpose of pointing out the proper numerals on the ribbon.
 70
 75

Now, as the machine is designed for adding numerals according to the decimal notation, and as the adding-index h contains twenty numerals, and as the apertures i and j are arranged above the slots g , I construct my adding-ribbon in this wise: I leave the lower end of the ribbon blank from the enlargement c at its lower end (see Fig. 5) up to the aperture i , where the first character in the row e appears, which in this case is a cipher e^2 . The numerals in this row are arranged in successive series of ten—viz., the nine digits and cipher—and these series extend throughout its entire length. The
 80
 85
 90
 95
 100
 105
 110
 115
 120
 125
 Fig. 1.

It will be observed that the numerals or digits composing a column to be added may be added in any desired succession, and that the operation of adding consists simply in inserting a pointed instrument of any kind in one of the perforations d in the ribbon and drawing the ribbon down as far as the limit of the slot will allow. To enable the pointed
 130

instrument to enter the perforation in the ribbon fairly, I form a groove in the front plate A^3 behind the ribbon and coincident with the perforations d . This groove is seen at the left in Fig. 1, where the ribbon is broken away to expose it. When the ribbons D are drawn down in adding, they coil themselves in the cells in the parti-cylinder A' , as seen in Fig. 3, and when the adding operation is completed the ribbons are again wound up on their drums C by means of a crank F on the projecting end of shaft B ; but as all the ribbons are wound up at once and as they will not usually be unwound (in adding) to an equal extent it is necessary that the drums C shall not be fixedly attached to shaft B . When one ribbon is wound up, the enlargement c at its end stops its further movement and its drum C slips on shaft B until all the ribbons are wound up.

A ratchet device G (seen in Fig. 4) prevents the shaft B from being turned backward. An inexperienced person might possibly disarrange the ribbons by the backward rotation of the crank if no means were employed to prevent such rotation. This ratchet device forms a convenient back-stop.

It is also essential that the shaft B should be held absolutely stationary while adding. To effect this I mount the handle l of crank F on the free end of a leaf-spring m , secured to the crank, and arrange a beveled "wipe" or latch n on the under side of said spring, which wipe snaps over and engages a fixed inclined stop o on the side plate of the casing, as best seen in Fig. 7. When the ribbons are wound up, the operator continues to turn the crank until latch n engages the fixed incline o , and this effectually holds shaft B against backward rotation. To prevent the ribbon from springing back, after an adding operation, from its resiliency, like a watch-spring from its barrel, I so arrange the slot b with reference to the drum C that the ribbon is quite sharply bent as it is led through said slot, and its movement through the same is resisted by friction.

To form the "cells" in the parti-cylinder A' , I usually spring an open ring x of sheet metal into said cylinder, (see Fig. 3,) said ring having a face width equal to the desired depth of the cell. Over this I place a flat disk y as a partition. Then I put in another ring x , and on this another disk y until all the cells are formed. This construction, however, is not essential.

I do not limit myself to the precise construction and arrangement of the parts of my machine as herein shown, as some variation therein may be made without materially departing from my invention. For example, good results may be obtained by omitting the drums C and shaft B and allowing the ribbons D to coil up in cells in the cylinder A in the same manner that they coil up in the cells in cylinder A' . In this case, however, it would be necessary to run back or

"wind up" the ribbons by means of a pointed instrument inserted in the perforations d . If the shaft B and drums C are employed, any suitable frictional device may be substituted for the spring a .

A milled button screwed onto the projecting end of shaft B might be substituted for crank F , or I might use a coil-spring to wind up the ribbon similar to that employed in tape-measures. I may also employ some other mode of preventing the recoil of the ribbon than that shown—as a detent, for example.

I do not limit myself to making the strip D in the form of a ribbon, as it might be in the form of a sliding plate, especially in large machines where long slides can be conveniently employed. Indeed, this part D , carrying the two rows of numerals e and e^x , may have any suitable or convenient form or construction. I have called said plate a "ribbon," because that is the form it has, as herein shown, and the form best adapted to small and compact machines.

I prefer to arrange the apertures i and j above rather than below, because when arranged below they would be liable to be obscured or covered by the hand of the operator. The apertures j need not necessarily be arranged above the level of apertures i . They might be arranged below said apertures, but not on a level therewith. The respective arrangement of the numerals in the rows e and e^x on the ribbon or strip D will be governed, of course, by the respective positions of the apertures i and j . For example, when the numeral of row e , visible at aperture i , shifts from one series to the next, as from 9 to 0, then the numeral of row e^x , visible at hole j , must shift from one series to the next, as from 1 to 2 or 2 to 3. As the apertures i and j are intended merely to designate, simultaneously, a certain numeral in each row e and e^x by segregating them from the others, this designation may be effected by any convenient means equivalent to that shown.

The leading feature of novelty is the part D , however shaped or constructed, bearing the row of numerals e to form the sum and also the row of numerals e^x , which designate the amount to be carried; whereby both of these rows of numerals are compelled to move together, and, combined with this ribbon or part D , means for designating or setting apart certain numerals in these rows, which function is performed in the present case by the apertures i and j .

I have denominated the numerals in row e the "sum" numerals and those in row e^x the "carry" numerals; but this is only for convenience. The numerals of the two rows, taken together, indicate the sum of the column of numerals being added, and if the designating-apertures i and j were placed on the same level the numerals on the part D , included in the rows e and e^x , would necessarily be arranged in simple arithmetical order or sequence.

Instead of designating the numbers in row e^x on the ribbon D by two figures or digits, as 10 11 12, &c., as seen at the upper part of Fig. 5, after the numbers exceed nine, I may use 0 for 10, 1 for 11, 2 for 12, &c., and gild or otherwise color, mark, or tint this portion of the ribbon beyond 9 in row e^x . I suggest this as a more economical mode of constructing the ribbon than that shown in the drawings. Ciphers (0 0 0, &c.) may, if desired, be marked on the ribbon in row e^x opposite the first series of numerals in row e . The numerals may be stamped on the ribbon or applied in any way.

15 Where the machine is designed for adding English currency, the right-hand ribbon will be reserved for farthings or half-pence, the next for pence, and the next for shillings. The pence-ribbon will have the numerals in row e arranged in series of twelve, and the carries will represent shillings. The shilling-ribbon will have the numerals in row e arranged in series of twenty, and the carries will represent pounds. If the right-hand ribbon were reserved for adding fractions—as eighths, for example—then the numerals in row e would be arranged in series of eight, and the carries would represent whole numbers. This will be readily understood by those familiar with such machines. The first cipher e^2 at the bottom of column or row e on ribbon D, Fig. 5, is not essential; but it is a convenience, as it enables the operator to see that his machine is set right at starting. It would serve as well or better if this character were an arbitrary one—as the mark or sign (+) of addition, for example.

From the foregoing description it will be seen that my machine or instrument is made up of eight (in this example) separate similar and independent adding mechanisms, each of which is an adding-machine of itself, and that each of these mechanisms has an adding-ribbon (or equivalent slide, disk, plate, wheel, or other carrier) bearing two series or rows e and e^x of numerals, one series to form the sum and the other serving to indicate the carries. These are characteristic general features of my invention.

50 I have stated that the several adding mechanisms in the machine are similar or alike, and they will be so or may be so in most respects, the variation being mainly in the numerals on the part D. For example, the numerals on said parts will differ for pounds, shillings, and pence and for adding fractions, and the ribbon or part D of the mechanism at the extreme left may have its numerals arranged in simple arithmetical order, as no carries and no designator therefor will be required in it.

Having thus described my invention, I claim—

65 1. An adding-machine comprising two or more independent adding mechanisms for adding the several columns of numerals, each of said mechanisms comprising a movable

part bearing numerals arranged in series in the proper order for indicating the sum of its particular column, an index to guide the operator in moving said parts, and designators for designating the numerals of the partial sum and the carries, substantially as set forth.

2. In an adding-machine, the combination, with a casing, of a flexible, resilient, or spring-like adding-ribbon, which is movable longitudinally, said ribbon being provided with the numerals which indicate the sum and carries marked in rows or series thereon, and an index provided with a series of numerals to guide the operator in moving the ribbon, substantially as set forth.

3. In an adding-machine, the combination, with a casing, of two or more longitudinally-movable parts D, mounted in said casing and each provided with longitudinally-extending series or rows of numerals, an adding-index, and means for designating the units-numeral and the numeral or numerals to be carried.

4. In an adding-machine, the combination, with the cells for the ribbons, of the ribbons provided with stops to limit their movement in one direction and prevent them from being drawn entirely out from their receiving-cells, the drums or reels to which said ribbons are respectively attached at one end, said drums being frictionally mounted on a common shaft, and the said shaft.

5. The combination, to form an adding-machine, of a front plate with cells at its ends to receive the self-coiling adding-ribbon, the face-plate bearing the index-numerals, the designators, and the self-coiling adding-ribbons arranged over the front plate and under the face-plate, said ribbon having in it perforations to receive an operating-stylus and bearing on it the sum and carry numerals, substantially as set forth.

6. An adding-machine comprising a movable part on which are marked a row of sum-numerals, arranged in successive series, and carry-numerals, and in which movable part is a row of properly-spaced perforations, a plate having on it a row of index-numerals arranged at the side of the row of perforations in said movable part and corresponding thereto, a designator to point out the numeral that is to appear in the sum, and a designator to point out the numeral that is to be carried, substantially as set forth.

7. An adding-machine comprising a casing, a series of numerals bearing perforated independently-removable ribbons arranged in said casing and capable of moving longitudinally and adapted to coil at either end, a slotted and perforated face-plate arranged over said series of ribbons, and means for carrying back all of the ribbons at one operation.

8. An adding-machine comprising a movable part provided with a row of numerals arranged in series from 0 to 9, another row of numerals for the carries, arranged abreast of the latter in the sequence and manner described, and a row of perforations to facili-

tate the movement of the part, and a slotted face-plate arranged over said movable part, a column of index-numerals, and designating-apertures, one over each row of numerals on the movable part to disclose said numerals.

9. An adding-machine comprising a movable part D, on which are marked a row e of numerals, arranged in successive series, a row e^x of numerals for the carries and a row of perforations d , a slotted face-plate arranged over said ribbon, having a column of index-numerals, and designators for pointing out the numeral of the row e that is to appear in the sum and the numeral of the row e^x that is to be carried, substantially as set forth.

10. An adding-machine comprising two or

more independent adding mechanisms for adding units, tens, &c., each mechanism comprising a movable ribbon bearing two rows of numerals e and e^x and a slotted face-plate arranged over said ribbon and provided with a row of index-numerals, an aperture to disclose the numerals in row e , and another aperture to disclose the numerals in row e^x , substantially as set forth.

In witness whereof I have hereunto signed my name in the presence of two subscribing witnesses.

CHAS. HENRY WEBB.

Witnesses:

HENRY CONNETT,
J. T. BROWN.