

(No Model.)

9 Sheets—Sheet 1.

W. S. BURROUGHS. CALCULATING MACHINE.

No. 504,963.

Patented Sept. 12, 1893.

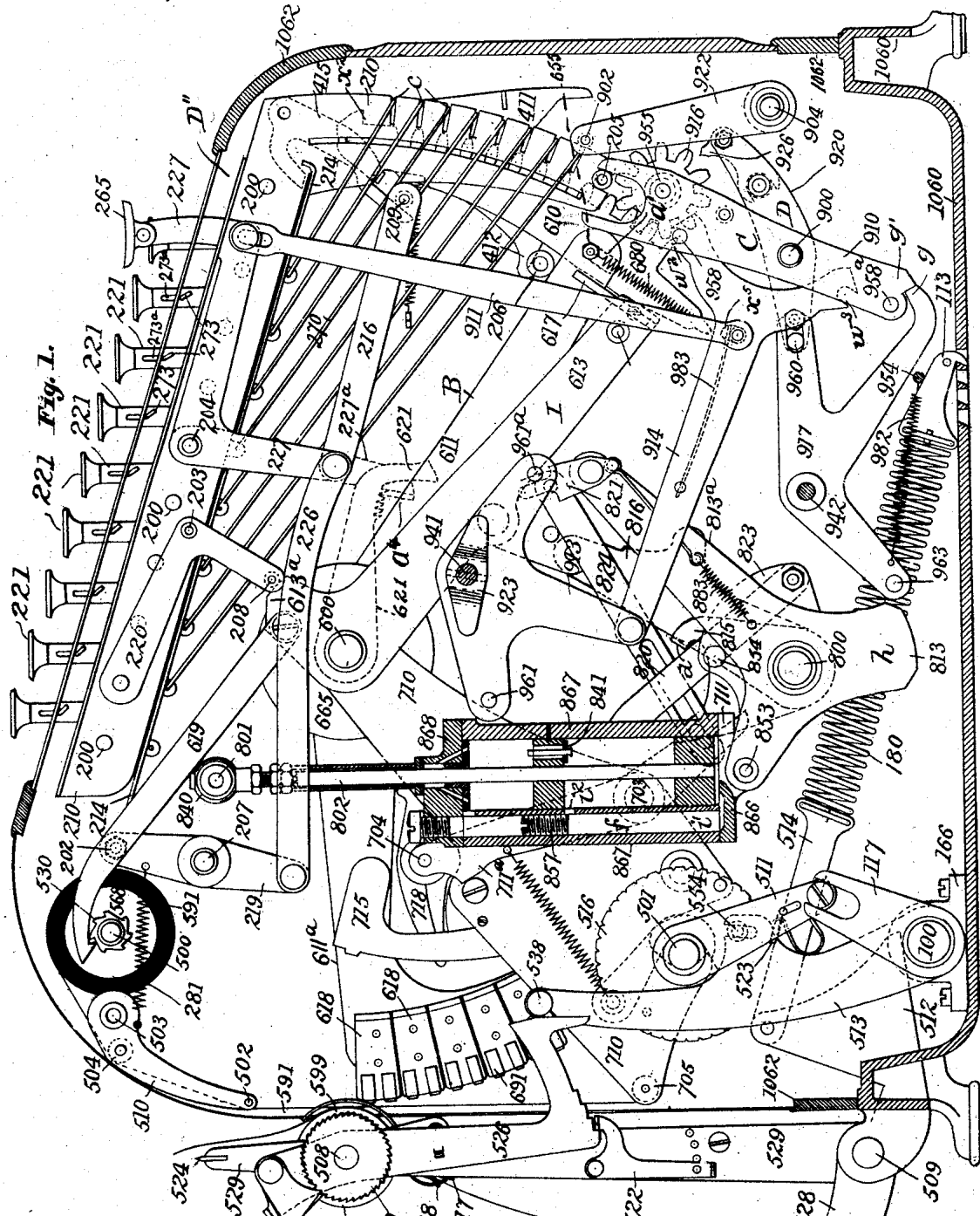

Fig. 1.

Witnesses:
 Robert W. Hours
 Allen W. Dobson

Inventor:
 W. S. Burroughs
 By Arthur J. Feman
 Atty

W. S. BURROUGHS. CALCULATING MACHINE.

No. 504,963.

Patented Sept. 12, 1893.

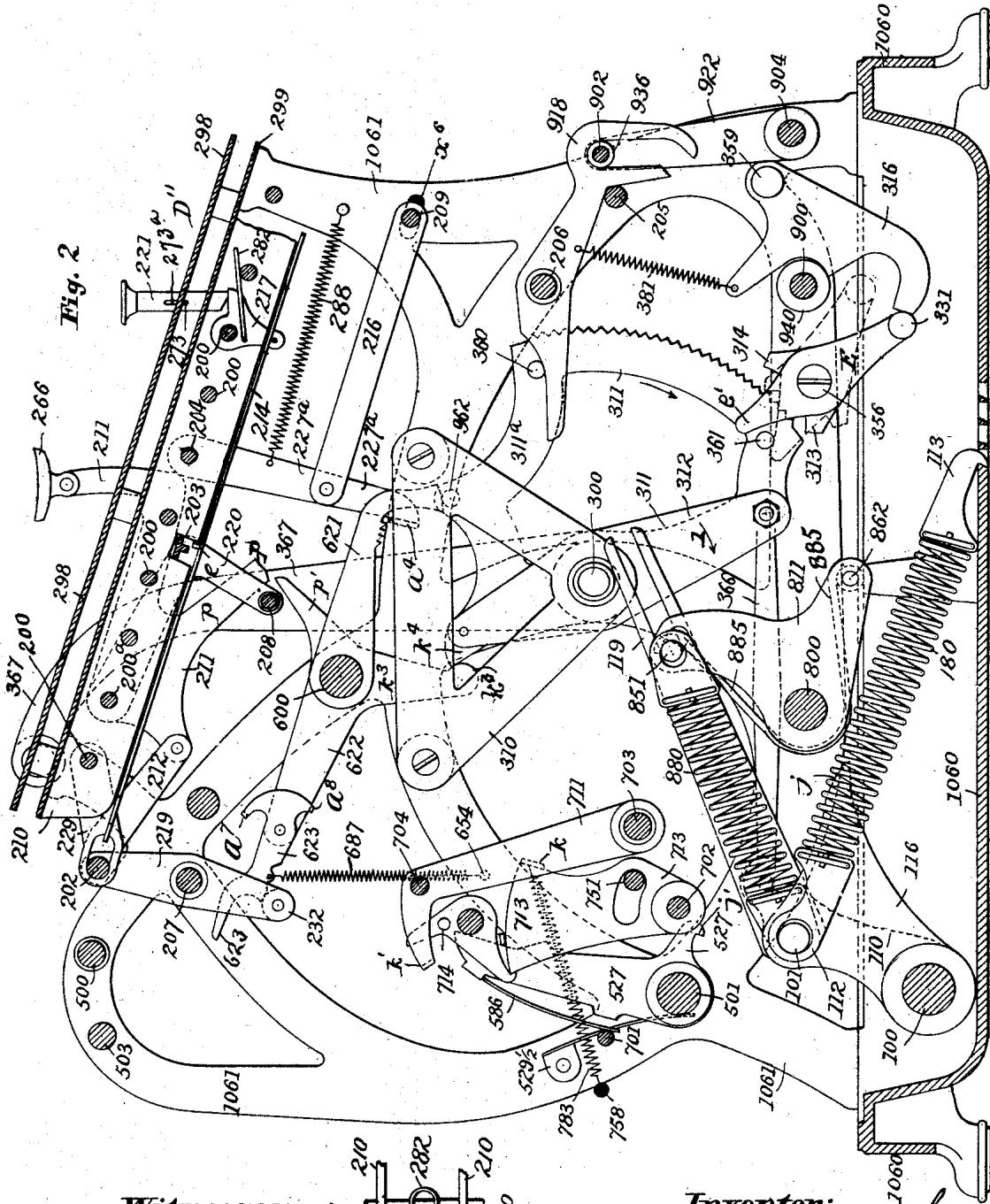
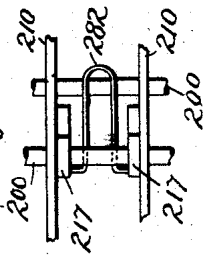

Fig. 2

Witnesses:
 Robert M. Nourse,
 Allen N. Dobson

Fig. 3.



Inventor:
 W. S. Burroughs
 Atty: J. M. Freeman
 Atty

(No Model.)

9 Sheets—Sheet 3.

W. S. BURROUGHS.
CALCULATING MACHINE.

No. 504,963.

Patented Sept. 12, 1893.

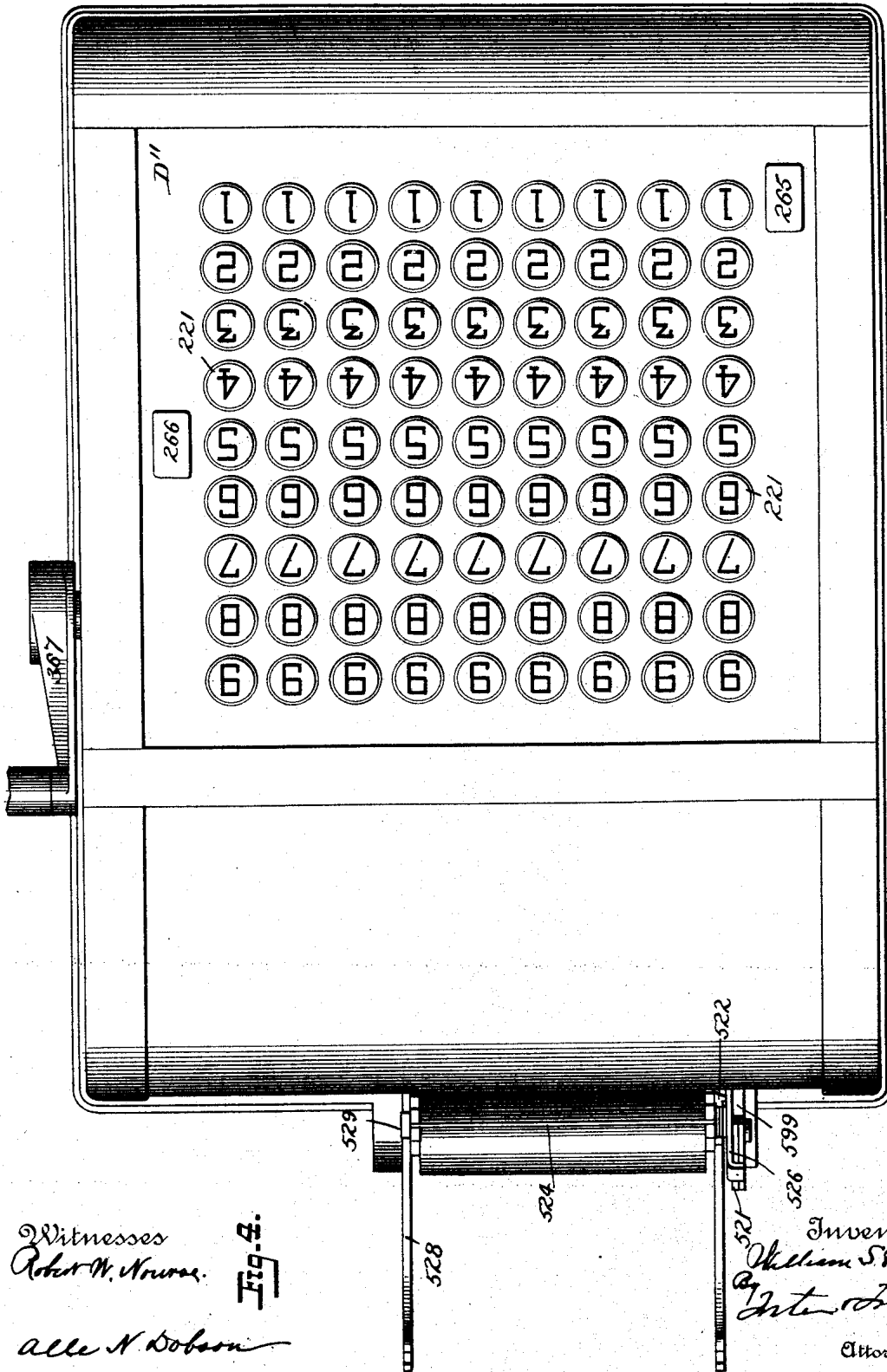

Witnesses
Robert W. Howard.

Fig. 5.

Allen N. Dobson

Inventor

William S. Burroughs
By John Freeman

Attorneys

(No Model.)

9 Sheets—Sheet 4.

W. S. BURROUGHS.
CALCULATING MACHINE.

No. 504,963.

Patented Sept. 12, 1893.

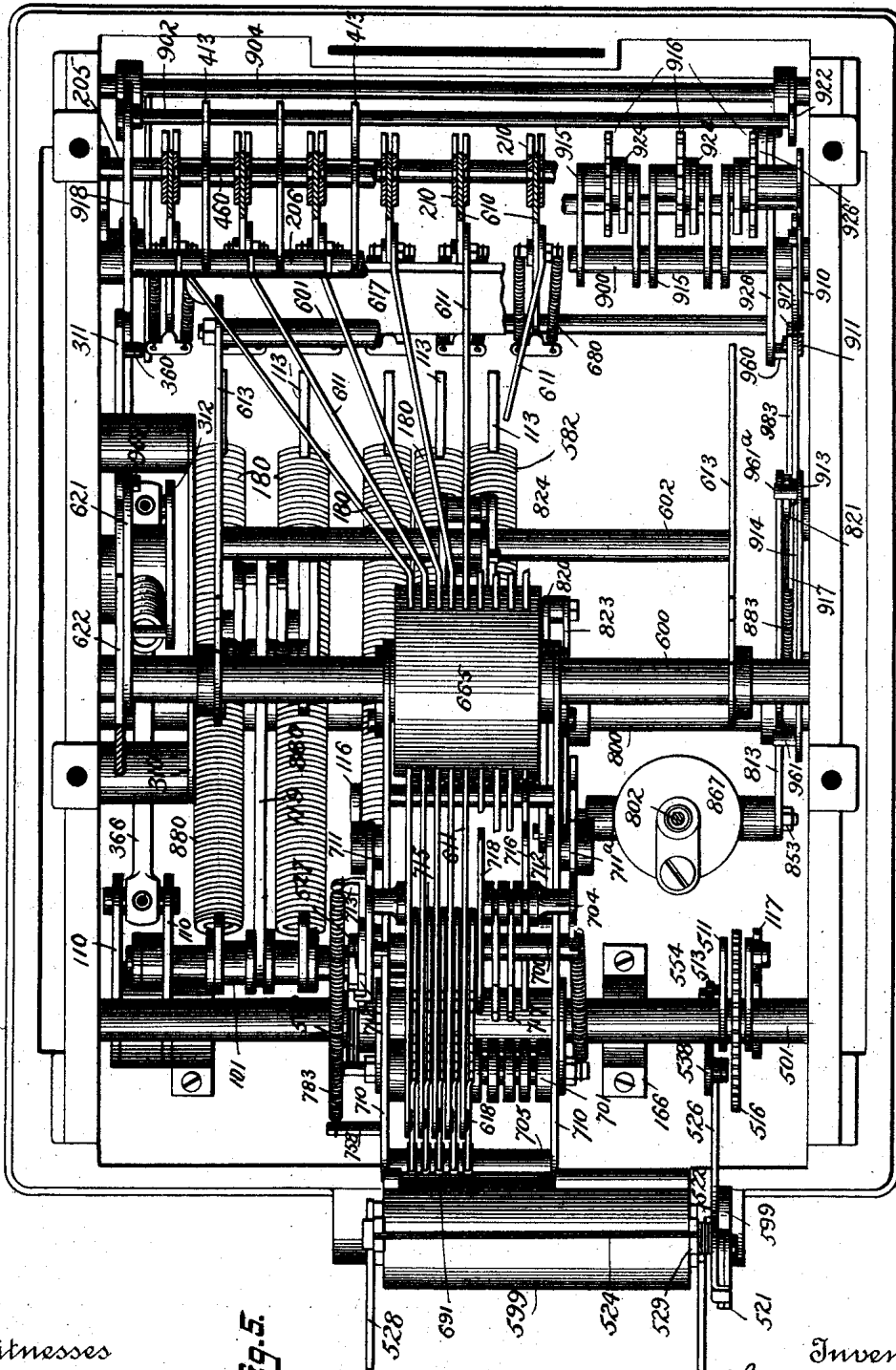

Witnesses
Robert W. Harris

Fig. 5.

Allen N. Dobson

Inventor
William S. Burroughs
By Inter & Francis
Attorneys

W. S. BURROUGHS.
CALCULATING MACHINE.

No. 504,963.

Patented Sept. 12, 1893.

Fig. 6.

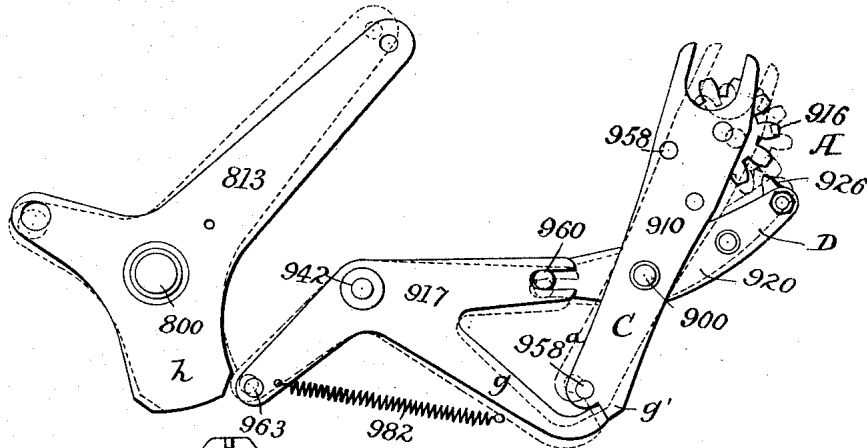

Fig. 5.

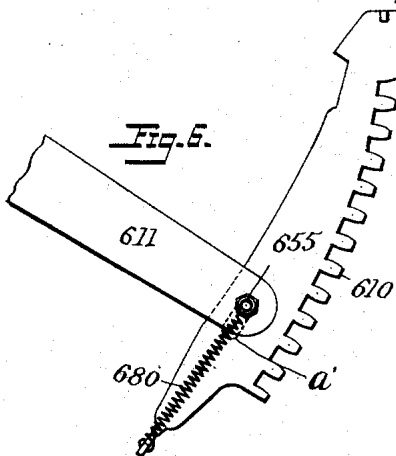

Fig. 7.

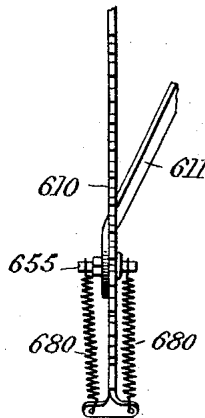
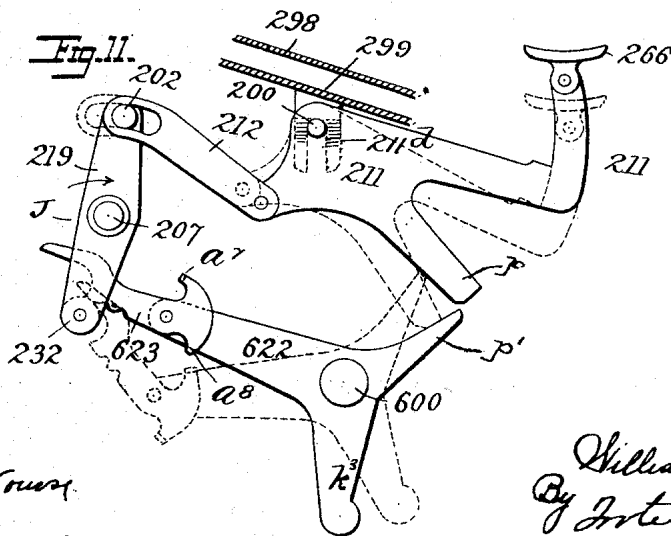

Fig. 11.



Witnesses

Robert W. Brown

Allen N. Dobson

Inventor

William S. Burroughs
By J. J. Freeman

Attorneys

(No Model.)

W. S. BURROUGHS. CALCULATING MACHINE.

No. 504,963.

Patented Sept. 12, 1893.

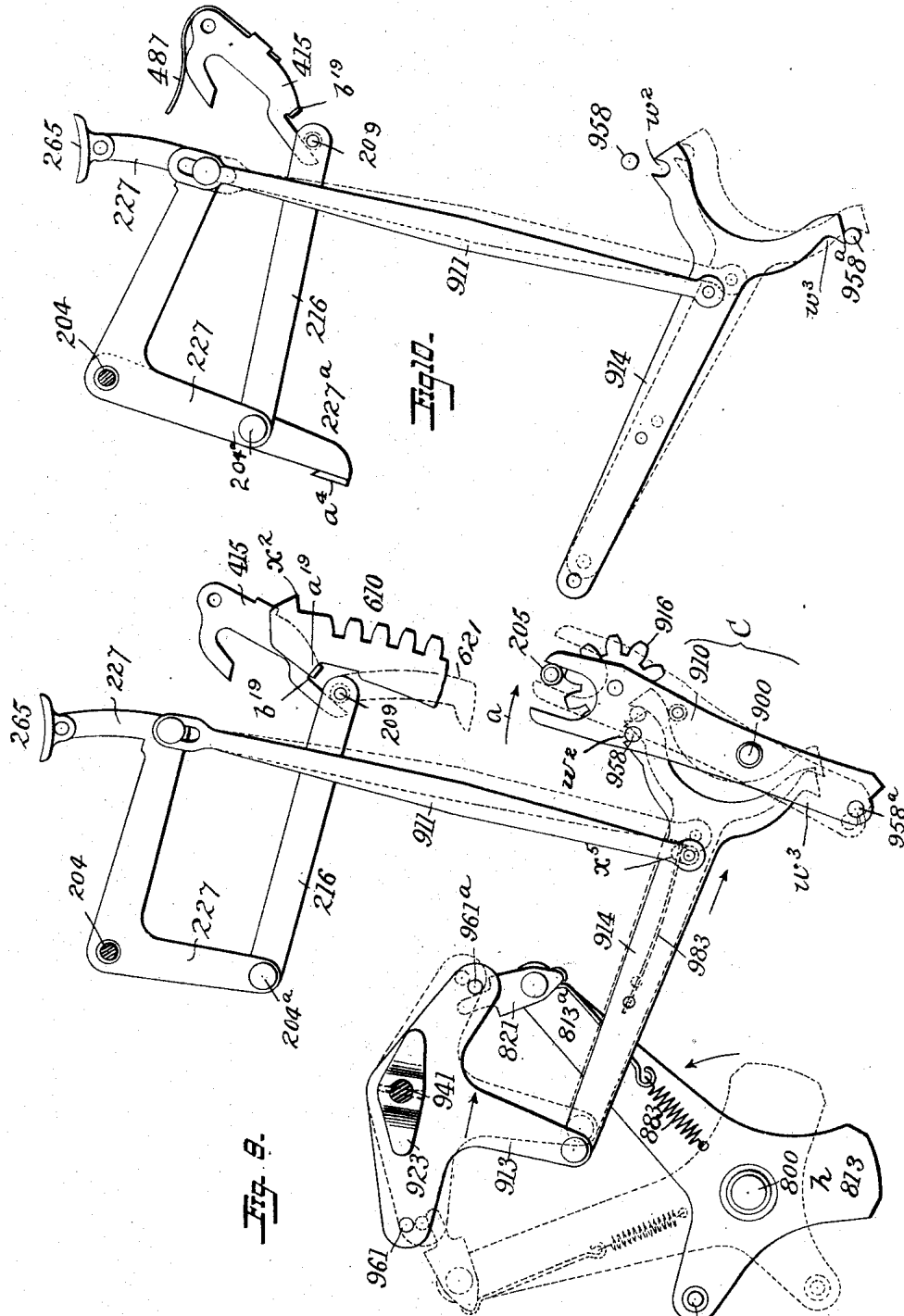

Fig. 9.

Fig. 10.

Witnesses
Robert W. Norris.
Alle N. Dobson

Inventor
William S. Burroughs
 By *853 J. M. & Freeman*
 Attorneys

(No Model.)

9 Sheets—Sheet 7.

W. S. BURROUGHS. CALCULATING MACHINE.

No. 504,963.

Patented Sept. 12, 1893.

Fig. 13.

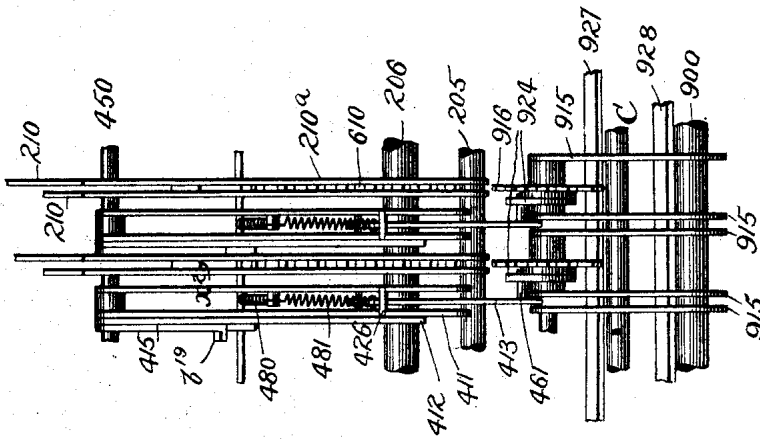
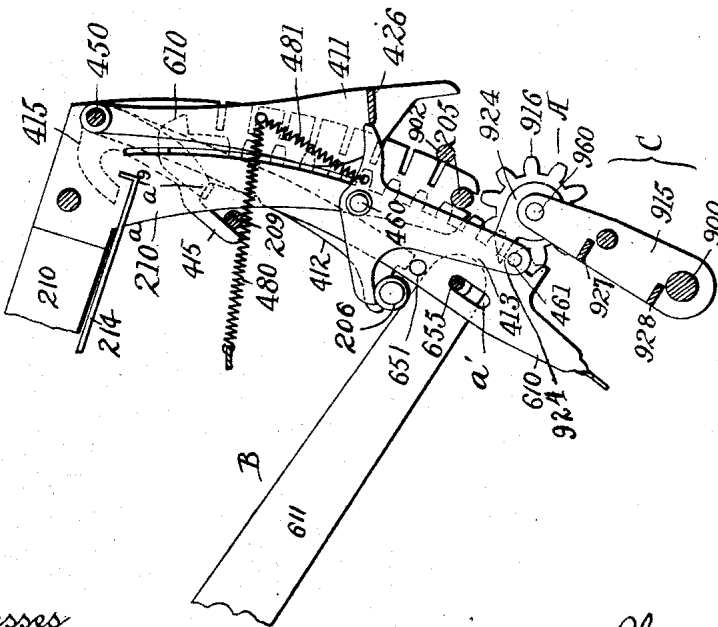

Fig. 12.



Witnesses
Robert C. Woods.

Allen N. Dobson

Inventor
William S. Burroughs
By
John J. Freeman

Attorneys

(No Model.)

W. S. BURROUGHS.
CALCULATING MACHINE.

No. 504,963.

Patented Sept. 12, 1893.

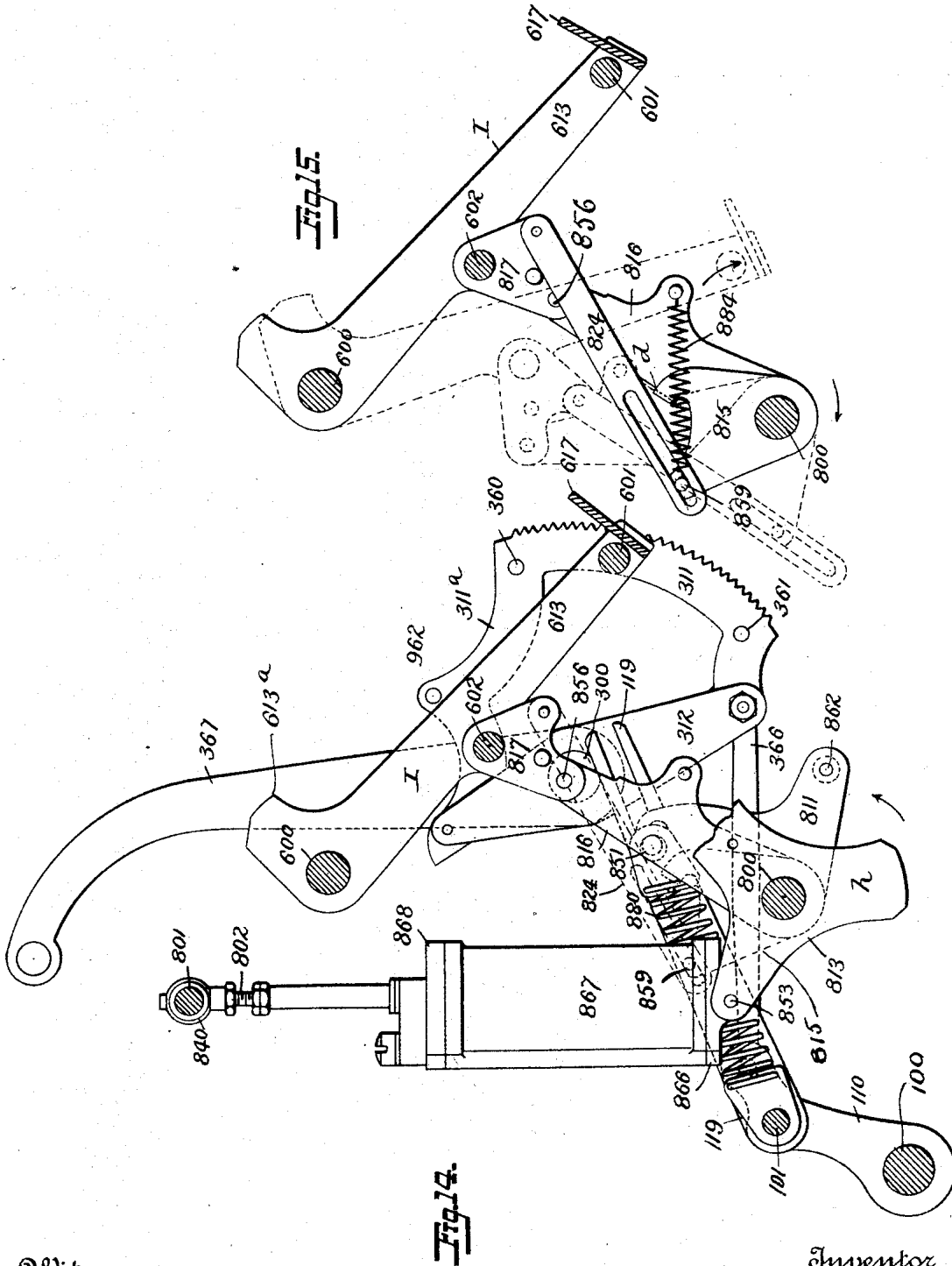

Witnesses
 Robert W. Hoopes,
 Alex. N. Dobson

Inventor
 William S. Burroughs
 By J. H. F. Ferman
 Attorneys

W. S. BURROUGHS.
CALCULATING MACHINE.

No. 504,963.

Patented Sept. 12, 1893.

Fig. 16.

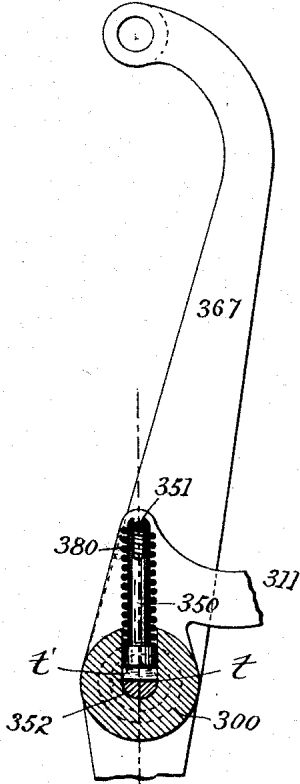
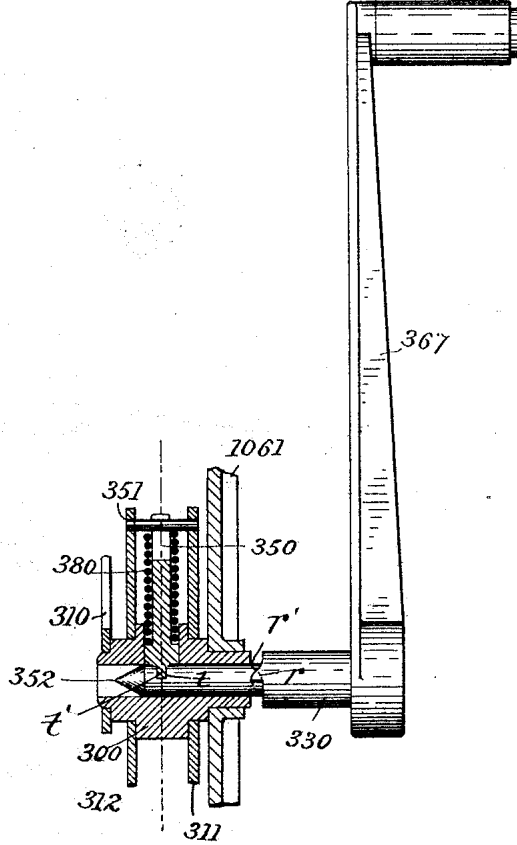

Fig. 17.



Witnesses:

Robert W. Nourse.

Allen N. Dobson

Inventor:

W. S. Burroughs.

By J. H. Freeman
Atty.

UNITED STATES PATENT OFFICE.

WILLIAM S. BURROUGHS, OF ST. LOUIS, MISSOURI, ASSIGNOR TO THE
AMERICAN ARITHMOMETER COMPANY, OF SAME PLACE.

CALCULATING-MACHINE.

SPECIFICATION forming part of Letters Patent No. 504,963, dated September 12, 1893.

Application filed May 5, 1892. Serial No. 431,964. (No model.)

To all whom it may concern:

Be it known that I, WILLIAM S. BURROUGHS, a citizen of the United States, residing at St. Louis, in the State of Missouri, have invented certain new and useful Improvements in Recording Calculating-Machines, of which the following is a specification.

This invention relates to certain new and useful improvements in calculating machines; and it consists substantially in such features of construction, arrangement, and combinations of parts as will hereinafter be more particularly described.

The invention has reference more particularly to the class of calculating machines, such for instance as is shown and described in Letters Patent Nos. 388,118 and 388,119, issued to me on the 21st day of August, 1888; and the object of the invention is to reduce the number of operating parts in such machines, without materially varying the principles of operation.

In the accompanying drawings—Figure 1, is a side elevation, in part section, showing such parts, as are more directly connected in operation, the remaining parts being omitted to prevent confusion. Fig. 2, is a side elevation, in part section, showing some of the parts illustrated in Fig. 1, but principally showing another series of parts that occupy a position farther to the right of most of those illustrated in Fig. 1. Fig. 3, is a detached detail plan, showing the arrangement of two of the key levers. Fig. 4, is a top plan view of the machine, as it appears when ready for use. Fig. 5, is a sectional plan view of the machine taken in a plane beneath the sets of key levers. Fig. 6, is a detached side elevation of one of the racks, together with its operating lever. Fig. 7, is an edge view of the parts shown in Fig. 6. Fig. 8, is a detached view of the devices for operating the pinion-carrying frame. Fig. 9, is a detached view of the devices for operating the pinion-carrying frame and for reversing the motion. Fig. 10, shows part of the devices represented in Fig. 9, in a different position. Fig. 11, is a detached view of the devices for throwing out of operation the automatic key-resetting appliances. Fig. 12, is a side view illustrating the means for operating the racks and

pinions; and also showing the "carrying" mechanism. Fig. 13, is a front view of the parts shown in Fig. 12. Fig. 14, is a view illustrating the connection between the main shaft and the handle-lever shaft. Fig. 15, is a detached view of some of the parts illustrated in Fig. 14. Figs. 16 and 17, are sectional views illustrating the connections between the operating handle and the shaft.

As in the class of machines embodying the principles of operation set forth and shown in my former Letters Patent referred to so there is in the present instance a key board marked D'', in which are arranged or set a number of series of keys, each series comprising nine keys 221, capable of vertical movement independently of one another. There is also a series of toothed pinions or wheels 916, (see Figs. 1, 5, 8 and 9,) constituting the register mechanism, which pinions or wheels are operated or turned by the movement of curved racks 610, loosely connected with rack levers B, that are operated in the manner hereinafter described. Located beneath the separate series of keys 221, are also separate series of crank levers 217, a lever for each key, and which crank levers are depressed or thrown rearward by the action of forcing down the keys substantially as described in the former Letters Patent hereinbefore referred to. Each crank lever is connected by its pendent arm with the rearward end of a rod 270, which rods at their opposite ends are bent or turned at c, to form stops which slide in the grooves of a stop-plate 210, pendent from the upper side of the machine, as shown in Fig. 1. The curved racks 610, near their upper ends are provided with lips x^2 , designed to engage the stops c, of the rods 270, whenever the stops are thrown back in their slots, and their corresponding racks lowered; and thus is the extent of the downward movement of the racks determined and limited. The rack-levers B operate the register devices, which may also be a recording device when a permanent record is required. If desired the register devices may be of the character indicated in the former patents referred to, but I prefer to construct them as herein shown, that is to say, of a series of type Fig. 1, carried at the end of the inner or rear

arms 611^a, of the rack levers B, and which is more particularly described in my application for Letters Patent, Serial No. 432,971, filed May 14, 1892. As herein shown the key board D'', consists of two plates 298, 299, Fig. 2, supported in any suitable manner by the side frames 1061 which are both secured to the base 1060, and which are connected transversely by various shafts and cross bars hereinafter referred to. The vertically operating keys are slotted as shown at 273^a, and extending transversely through the slots of such keys as are on the same transverse line are the cross-rods 273 Fig. 2, the arrangement of such rods being between the plates 298 and 299, and their purpose being to prevent the keys from being withdrawn or thrown off of the said plates. The keys 221, rest upon the crank levers 217 below them, and said crank levers are supported upon cross-bars 200 Fig. 2, so as to swing; and located upon said cross-bars also is a series of plates 210, each of which extends alongside of or adjacent to the crank-levers of each series, and the said crank-levers are caused to be pressed against the sides of said plates by means of springs 282 Fig. 3. By this construction the crank-levers of each series are caused to press against their adjacent side plates with sufficient friction to hold the crank-levers in the positions to which they are set, and they are likewise prevented from movement by jarring.

As in the case of my former patents, the pendent arms of the crank levers pass through slots in slotted bars 214 see dotted lines, Fig. 2, extending from front to back of the machine beneath each series of keys. The said bars as herein employed have their forward ends turned upward, see Fig. 1, to form lips for engaging the crooked fingers of suitable retainers 415, Figs. 1, 9, and 10, such retainers being also formed or provided with lips b¹⁹, that engage shoulders a¹⁹, of the racks 610, when the latter are in their upward position (see Figs. 1 and 9). Thus by depressing any one key of a series and thereby rocking its crank-lever 217, the bar 214, operating in conjunction with such series, is moved back, and, by the connection formed between the lips of such rod and the crooked finger of its retainer 415, such retainer will be thrown upward in a manner to release engagement between its lip b¹⁹, and the shoulder a¹⁹, of the co-operating rack. By pressing upon any key, the crank lever beneath the same is swung backward and the stop c of the rod 270, is thereby drawn to the end of its slot in the guide-plate 210, in position to be struck by the shoulder x², of the corresponding rack 610.

In the construction illustrated in my former Patent No. 388,119, the racks are a part of and swing with their levers B, upon the supporting shaft 600 while the rear arms 611^a of said levers have a slight independent movement. In the present construction the rear arms 611^a, and the front arms 611, of the le-

vers B, are rigidly connected, while the racks 610 have a slight vertical movement independent of the front arms, which movement is permitted by a movable connection between the lower ends of the racks and their front arms. Thus, as best shown in Figs. 6 and 7, the arms 611, are provided with pins 655, which enter slots a', in the racks 610, and the said arms and racks are connected by springs 680, which tend to normally lift or elevate the racks to the limit of their upper movements. This means of connection permits the operations requisite to move any one of the pinions 916 one step whenever the pinion next preceding it or of lower order completes a revolution, for the purpose of carrying "one" to the pinions of the next higher order, as will be more fully understood from the detailed description in the patents before referred to. The means for securing this independent and increased movement of any one of the racks at the proper time, are best shown in Figs. 12 and 13, from which it will be seen that each pinion 916 has at one side a cam 924, having a projecting toe adapted to engage a pin 461, upon a lever 413, a stud 460 of which lever rocks in bearings in depending arms 210^a, of adjacent plates 210; each lever 413, controls this independent movement of the adjacent rack 610, and is in turn operated by the movement of the next lower rack.

The racks 610, are provided with studs 651, which when the arms 611, of levers B, are carried to the limit of their upward movement, make contact with the lower ends of detents 412, pivoted to swing on studs 450, of adjacent plates 210, so that the racks can accompany the arms 611 only until the studs 651, strike the detents 412, after which the arms 611, continue their upward movement, and the pins 655 are brought to the upper ends of the slots a'. If the detents 412 are swung out of the way as presently described, the springs 680, see Figs. 6 and 7, lift the racks sufficiently to turn the pinions 916 one step farther than they would be carried, did not the described movable connection between the racks and levers B, exist. It will be understood that it is only at the times mentioned that any one or more of the racks are thus operated and that ordinarily the racks will only be lifted upward in proportion to the extent to which their downward movement is limited by the stops c.

In order that the detents 412, shall be caused to swing out of engagement with the studs 651, of the racks at the proper time I provide a striker 411, for each detent which strikers each consist of an arm pivoted upon the stud 450, and having a portion 426, normally resting against or making contact with the toe of the corresponding lever 413, the said strikers being drawn toward the levers by the action of springs 480, and when the cam 924 of one pinion strikes and pushes back the stud 461, of the lever 413 corresponding with the pin-

ion of the next higher order which is to be moved one step in excess of what it would ordinarily be moved, (see Fig. 12) the said lever will be swung so as to carry its toe away from contact with the portion 426, the striker will be drawn inward suddenly by the spring 480, until it strikes the detent 412, whereupon the latter is carried out of the way of the stud 651, and the springs 680 then raise the corresponding rack 610 and the latter will turn the pinion 916 with which it engages one step.

The pinions 916, are carried by a swinging frame C, (Figs. 12 and 13) consisting of duplicate arms 915, which are fixed to a cross-shaft 900, the said duplicate arms all being connected by transverse bars 927 and 928. The said frame C, swings for the purpose of carrying the pinions 916, into and out of engagement with the racks 610, to effect the same results that are effected in my aforesaid patents carrying the pinions into and out of engagement with the racks. The strikers 411 are all thrown forward by the movement of a cross bar 902, (Figs. 1 and 2,) carried by arms 922, mounted on a rock-shaft 904, so that said strikers again engage the toes of the levers 413.

It is important to lock all the keys 221, in their positions after any of the keys have been set. In order to effect this locking I employ a cross-bar 203, (Figs. 1 and 2) which extends across all of the slotted bars 214, and engages with lugs *e*, with which each of the said slotted bars is formed or provided. When the bars 214, are forward or in their normal positions, the lugs *e*, thereof are also forward of the cross bar 203, as in Fig. 2; and whenever a bar 214 is moved back by depressing the key corresponding thereto, the lug *e*, of such bar will be back of the cross-bar. The said cross-bar 203, is supported between two arms 220, (one on each side of the machine) suspended loosely on the shaft 200^a, and said bar is normally held up out of engagement with the lugs *e*, of the bars 214, by means of the cross-rod 208, which is supported between the dependent members of the arms 220, and which rod normally rests upon cam edges 613^a, Fig. 1, of the lifter-frame I hereinafter referred to. It is obvious that whenever the lifter frame is operated as described hereinafter, the cam edges 613^a, will pass from beneath the rod 208, and the arms 220 will thereby drop and carry with them the bar 203, which latter engages the lugs *e*, of the bars 214, thereby preventing any movement of any one of the said bars or the depression of any of the keys.

It is evident that any suitable form of locking device may be employed for holding, binding, or clamping the bars 214, upon initial movement of the crank levers, with like effect, and that the locking bar 203, may be applied to any part moved by the keys. All the keys are restored to their normal positions by moving the bars 214 forward simultaneously, and this is effected by the forward

swinging movement of a cross-bar 202, (see Figs. 1, 2, and 11,) carried between the upper ends of two arms 219, rigidly mounted upon a rocking shaft 207, which cross-bar 202 makes contact with the rear ends of all the bars 214. The movements of the bar 202, are limited by slots in the pivoted arms 229, suspended from the upper cross-rod 200 Fig. 2, or that cross-rod which is to the extreme rearward end of the machine, see Fig. 2. The rocking of the shaft 207, is produced both automatically and by hand, as hereinafter described, and is held in its backward position by means of a spring 281, see Fig. 1.

In the construction illustrated in my Patent No. 388,118, the operating handle is connected to operate the shaft upon which the rack-levers B, move; but in order to protect the working parts of the machine from undue strain and speed by carelessness on the part of the operator, I in this invention make use of a main shaft 800, yieldingly connected in one direction to a counter or supplementary rock shaft 100, which is positively operated by the operating handle 367 attached to the shaft 300 during its forward movement, but is allowed to return under the action of the spring 180.

The various rack-levers B, are lifted after they have fallen by the operation of a lifter frame I, which is for the purpose of elevating the racks, as will appear. The said frame I, consists of two arms 613, carried by the shaft 600, and supporting the cross lifter bar 617 Figs. 1, 5, 14, and 15, that engages with the lower edges of the arms 611, of the rack levers B. The shaft 600 is rocked from the shaft 800, to swing the lifter frame I, by means of a connection, Figs. 14 and 15, which I prefer to make in the form of a toggle to secure sufficient power at the termination of the motion to lift the rack arms 611, against the power of the rack motor springs 680. The toggle connection is in the form of two levers or arms 816, and 817, the arm 816 swinging freely on the shaft 800, and the arm 817, pivoted by any suitable pivot, as 602, to the lifter frame, and the pivot 856, which connects the arms 816, 817 is carried slightly beyond a central line drawn through the shaft 800 and the pivot 602, for the purpose of locking the parts when they are at the limit of their forward position. The shaft 800, carries an arm 815, having a lip *d*, which, upon the movement of the shaft in the direction of the arrow, Fig. 15, presses against the toggle arm 816, and carries the toggle to the forward position shown in said figure. It is necessary to throw the pinions 916, out of gear before releasing the rack levers in order to prevent the pinions being turned by the downward movement of the racks, and, therefore, the shaft 800, by which the pinion frame C is operated, must have a reverse movement, independent of the toggle connection, sufficient to enable the pinions to be swung out of the way before the toggle is

loosened, for which purpose I connect the toggle loosely with the said shaft 800. Thus the arm 815, is connected with the arm 817, of the toggle through the medium of a connecting rod 824, having a slot receiving a pin 859, on the arm 815, (see Figs. 1 and 15) which pin only makes contact with the lower end of the slot after the shaft 800, moving in the direction of the arrow Fig. 14, has caused the pinions 916, to swing out of gear with the rack, when the arm 816, will be swung to carry its pivot 856, backward past the central line; and the weight of the connected parts will cause the lifter frame I, to drop, and the toggle connection will be carried to the position shown in dotted lines, Fig. 15. To insure this final operation, and, as auxiliary to the weight of the parts, I make use of a spring 884, connecting a point upon the arm 816, and the arm 815.

The motion is communicated from the handle shaft 300 to the main shaft 800, by means of the devices best shown in Figs. 2 and 14, in which an arm 312, on the handle shaft 300, is connected by a rod 366, with an arm 110 on the rock-shaft 100; and a forked rod 119, pivoted to a cross-rod 101, (see Fig. 5) extending between the arm 110 and another arm 116, receives within its fork a stud 851, upon a two armed lever 811 mounted upon the shaft 800. The cross-rod 101, and the upper arm of the lever 811, are connected by means of springs 880 Figs. 2 and 14, attached at the ends of the said cross-rod and arms, so that when the shaft 300 is rocked in the direction of the arrow marked 1, Fig. 2, the arm 110 is carried backward, tending to distend the spring 880, rocking the lever 811, and turning the shaft 800, but not with a positive movement, so that if the handle is jerked forward too rapidly the effect will be to temporarily distend the spring, and the contraction of the latter will gradually draw upon the lever 811, and turn the shaft 800, without an abrupt shock. I supplement this yielding connection by a dash-pot Figs. 1 and 14, the piston rod 802 of which is connected at 801, to the frame and carries a piston at the lower end, while its cylinder 867, is connected to an arm of a lever 813, mounted upon the shaft 800. The cylinder has a diaphragm secured about midway thereof, with a valve 841, opening downward to permit the fluid to flow into the chamber below from which it circulates to an outside channel f through two small openings or channels i^1, i^2 , when the cylinder is moved downward or upward by the action of the lever 813, and thereby governs the rate of movement resulting from the action of the springs 880. By this means I absolutely prevent any detrimental strains or abrupt movements. Either one of the channels i^1, i^2 , may be controlled in size to regulate the speed in either direction. As shown, an adjusting screw 857, turns in the channel f , so as to be carried to a greater or less extent over the opening i^2 ,

which opening is in the partition between the channel f , and the main cylinder 867.

The return movement of the parts above described is effected by any suitable controlling spring, as, for instance, springs 180, Figs. 1 and 2, having an adjustable hooked connection 113 for engaging any one of a series of notches in the base 1060, and connected by a link 112, with the cross rod 101. If the handle were drawn forward and released too rapidly there would not be time for the proper movement of the parts connected with either the rack levers or the recording mechanism, before the return movements effected by the springs 180. I therefore provide means for temporarily restraining the action of the springs 180 until the other movements are accomplished. Thus the arm 116, mounted on the shaft 100 has a toe j , which when the shaft 100 is turned back to its full extent engages a shoulder j' , (Fig. 2) upon a catch lever 527, swinging on a shaft 501, and pressed forward by a spring 586, attached to said lever 527, and bearing against a bar 701. As the shaft 800 rocks to its extreme backward limit, a stud 854, on the arm 823 (Fig. 1) strikes the lower end of an arm 711, upon a rock shaft 703, which carries arms 711 and 711^a, supporting between them a cross-bar 704; and upon the arm 711^a, is a lip k' , (Fig. 2,) which on the forward movement of the arm makes contact with the upper arm of a catch or lever 714, the lower arm of which has a hooked end engaging a striker plate 713. The said striker plate has a lip k , that is brought against the forward edge of the lever 527, with a quick percussive action under the influence of a spring 783, (Fig. 2) to vibrate the lever 527, and release the arm 116, as the shaft 800 terminates its movement, whereupon the shaft 100 and parts connected therewith will be released and returned to their normal positions. After the release of the toe j the first part of the forward movement of the shaft 100, and forked rod 119, will be under the influence of the springs 180 and the dash-pot will not act until the end of the slot in the rod 119, is in contact with the pin 851, and the movement of the levers 811, and 813, begins. It is, therefore, desirable to prevent any shock upon releasing the arm 116. This is done by means of wire springs 885, held upon a small cross rod 862, (Fig. 2) arranged beneath and backward of the shaft 800, and which resists the blow as the end of the slot in the rod 119, makes contact with the pin 851, which pin 851, is not fixed to the lever 811, but has a slight movement, in a slot in the arm thereof, and is held at the end of said slot by the springs 885.

After the movement of the shaft 300, rocked by the action of the operator upon the handle 367, once begins it is important that it be completed in the same direction, and I therefore provide the shaft 300, with a curved rack 311, Figs. 2 and 14, adapted to engage the teeth

313, 314, of a double pawl E, hung to the side frame and having a sprung end e' , that bears frictionally against the side of the rack 311, so that when the latter begins to swing in the direction of its arrow, Fig. 2, the pawl E (bearing with a terminal lug 331, against the end of a spring actuated arm 316) will maintain its position, without engaging the rack but if any action is taken to reverse the movement of the shaft, 300, the friction between the arm e' , and the rack will carry the pawl E, to a position for the tooth 313, to engage the rack and prevent any return movement. When, however, the shaft 300, has been rocked to its full extent a stud 360, of the rack striking the side of the part e' of the pawl will swing the latter to one side forcing out the spring arm 316, so that the lug 331, passes to the position shown in dotted lines, Fig. 2, whereby the teeth 313 and 314 of the pawl are brought to such a position that the rack 311 can move back as the shaft 300, returns toward its first position. This movement, however, cannot then be reversed, because of the frictional adhesion of the part e' , to the rack 311 which then would cause the pawl to turn so as to bring the tooth 314, into engagement with the rack; but as this movement is completed, the stud 361 of the rack is brought against the opposite side of the part e' , and restores the pawl against the action of the spring actuated arm 316, to the position shown in full lines, Fig. 2. The cross-bar 902, Fig. 2 the movement of which restores the strikers 411, to their set or normal position, shown in Fig. 12, is operated by means of a cam lever 918, Fig. 2, pivoted on the shaft 206, and operated by a stud 962, upon the frame carrying the rack 311, as the rack reaches the limit of its movement in the direction of the arrow. The cam lever 918, has a slot for receiving the cross-bar 902, the edges of which slot are of such a shape as is required to carry the bar 902, outward, as the cam end of the lever is raised, and draw it inward, as it is depressed under the action of a spring 381, which connects the lever 918, and the arm 316, and serves therefore, also as a means of imparting a yielding pressure to said arm. The frame C, Figs. 9 to 13 that carries the pinions, 916, is swung inward and outward through the medium of a T-lever 913, pivoted between its two upper arms to the side frame on a stud 941. Motion is transmitted to the frame C from the pendent arm of the lever 913, through the medium of a connecting rod 914, which as shown, and for the purposes described hereinafter, is forked at its forward end and is provided with a notch w^2 in one tine or member of the fork to receive a stud, 958, on the frame C above the shaft 900, and with a notch w^3 in the other tine or member of the fork to receive another stud 958^a on the frame C, below the shaft 900. The forward end of the connecting rod 914, is supported by a link 911, from a stud upon the bell crank lever 227, at the left hand side of

the machine connected at its corner to a shaft 204, extending through the plates 210.

It is necessary in ordinary operations, to throw the pinions 916, out of gear with the racks 610, at the beginning of the movement of the shaft 800, and to throw them into gear at the beginning of the return movement for which reason I provide the shaft 800, with an arm 813^a, carrying a reversible spring actuated pawl 821, which engages with studs 961, 961^a, upon the opposite arms of the lever 913. As the shaft 800, and its arm 813^a, swing in the direction of the arrow, Fig. 9, when the handle lever 367 is first drawn forward, the pawl 821, engages the pin 961^a and swings the lever 913, to throw forward the connecting rod 914 and the top of the frame C in which position they remain until the shaft 800 completes its movement in one direction. The pawl 821, as it passes below the pin 961, swings over to the position shown in dotted lines, Fig. 9, and as the shaft 800, is swung in the opposite direction, the pawl will engage the pin 961, so as to reverse the oscillation of the lever 913, and carry the pinions into engagement with the racks.

In order to effect the transfer of the amount registered upon the wheels of the sight register to the wheels of the printing register, as set forth in lines 26 to 95, page 6, of Patent No 388,118, it is necessary to vary the action above described and instead to retain the pinions 916, in gear with the racks during the entire forward movement of the handle. I, therefore, provide means for reversing the action. Thus, the lever 913, is thrown out of action upon the frame C, by rocking the bell crank lever 227, to lower the link 911, and the connecting rod 914 as shown in full lines Fig. 10, so that the upper tine of the latter will not engage the stud 958, during the forward movement of the operating handle, and the lever 913, will swing forward without, in any way, affecting the position, of the frame C, and if the lever 227, is retained in the position shown in Fig. 10, the arm 914 as it completes its forward movement will drop over the pin 958^a, as shown in dotted lines, Fig. 10, and upon the backward movement of the lever 913, the lower tine of the lever 914, will engage the pin 958^a, and swing the frame C, to carry the pinions, 916, away from the racks. The lever 227, is provided with an upwardly extending arm, which carries a thumb piece 265, above the top of the key-plate, so as to enable the operator to manipulate the lever.

It is often necessary in printing long lists of amounts to divide the list into columns of reasonable length in which case it is desirable after printing the total at the bottom of one column to carry it forward to the top of the next column. This is effected automatically as follows: The thumb piece 265, is depressed thereby rocking the lever 227, as above described; but if released at any time during the forward movement of the operating lever it will return at once under the action of the

spring 288, and will lift the arm 914, and thus prevent the notch w^3 , of said arm from engaging the stud 958^a, on the return movement of the operating lever, thus leaving the pinions 916, in gear with the rack 610, during both the downward and upward movement. By this action the pinions 916, are returned, each to its respective position as prior to the taking of the total; by repeating the operation above described the same total is printed at the top of the next column and the pinions return to position, and as other amounts are set up and printed they will be added to the total already on the pinions. All of the racks 610, should be released prior to the adjustment of the lever 227, and this is effected by connecting a cross bar 209, with the pendent arms of the levers 227, and 227^a, by means of the two parallel links 216, Figs. 1, 2, 9, and 10. It should be understood that the levers 227 and the levers 227^a are on opposite sides of the machine, and are connected by the shaft 204. The cross-bar, 209 extends beneath the terminal finger of all the retainers 415, each of which has a spring 487, tending to throw it down. As the lever 227, is released, and returns to its normal position, it is locked, by reason of the parts being again restored as before. Consequently a slight play in the arm 911, is necessary to permit the upper tine or member of the fork of the arm 914, to ride under pin 958. This play is afforded by a slot x^5 , in the lever 914, in which enters a stud on the rod 911, a spring 983, lifting the lever 914. To prevent movement while the machine is in motion, the lever 227 is locked by a toothed arm 621, Figs. 1 and 2, hung to the shaft 600, the teeth of said arm engaging with a projecting lip a^4 , upon the arm 227^a, extending from the shaft 204, and the arm 621, has its end extended downward, so as to be struck by the stud 962, on the rack frame 311, when the handle lever 367, returns to its normal position, thereby lifting the bar 621, and unlocking the lever 227, and connected parts. The lever 913, is held, in any position to which it is thrown, by means of a flat double arm friction spring 923, Fig. 9, secured to the stud 941, the arms of which spring bear against the lever 913, with sufficient frictional force to retain the lever in any position to which it is set, until sufficient power is applied to swing the lever. To prevent the pinions 916, from turning, after they have been thrown out of gear with the racks, I make use of teeth 926, Figs. 1 and 8, preferably with beveled edges which are carried in between two teeth of the opposite pinions to temporarily lock them whenever the latter are carried away or from the racks, the said teeth at other times, being drawn back to permit the pinions to turn. The teeth 926 are carried by a vibrating frame D, swinging loosely on the shaft 900, Figs. 1 and 8; said frame consisting of side arms 920, connected by stay-rods. As shown, one of the arms 920, is provided with a stud 960, entering a slot in

a three armed lever 917, which is pivoted on a stud 942, to one of the side frames. The lever 917, is drawn in one direction by a spring 982, and has an arm g , with a double beveled end engaging with a double beveled lug g' , on the end of one of the side arms of the frame C, so that as the latter swings in either direction, it will depress the arm g , and swing the lever 917, so as to swing the frame D, and throw in all of the teeth 926, until the points of the projections g, g' , pass each other, after which, the lever 917, will reverse its motion, and the teeth 926, will be carried out under the action of spring 982. It is desirable to lock the frame C, in either position to which it is set, as soon as it has been put in said position, and this I effect by securing to the shaft 800, a cam h , which may be part of one of the arms on the lever 813, Fig. 8, the edge of which cam is carried above a stud 963, of the lever 917, as soon as the shaft 800, has moved sufficiently to set the frame C, to one position or the other. The presence of the edge of the cam h , above the stud 963, prevents any rocking of the lever 917, or movement of the frame C.

To correct any errors made in striking the keys, it is necessary to restore them to their elevated positions, which restoration must, of course, be effected before any movement of the hand lever 367.

Instead of using a separate key and mechanism, I make use of the key 265, by connecting one arm of the lever 227, through the medium of a link 226, Fig. 1, with the lower end of one of the arms 219, mounted on the shaft 207, so that by depressing the key 265, and swinging the arms 219, the cross bar 202, is brought against all the slotted bars 214, and the keys are thereby restored to place. It is necessary to automatically elevate all the keys at the latter end of the stroke of the hand lever 367, after the functions of the parts set by the keys have been performed, and to effect this automatically, I rock the shaft 207, and bring the bar 202, against all the bars 214, by means of a lever 622, Figs. 2 and 11, on the shaft 600, one arm of which lever carries pivoted thereon a pawl 623, see Fig. 11, the movement of which is limited by projections a^7 , and a^8 , overlapping the edges of lever 622. As the lever 622 turns from the position shown in dotted lines, Fig. 11, to the position shown in full lines, the pawl 623 engages the stud 232, on one of the arms 219, and swings the latter in the direction of the arrow Fig. 11, and then escapes from the stud to the position shown in full lines, the arm 622 being operated by the contact of an arm k^3 , on the lever 622, Fig. 2, with a projection k^4 , of the rack frame 311^a. In this position the further swinging movement of the arms 219, is not interfered with.

It is, at times, quite important to repeat the same number two or more times, as for instance, when a bank teller has to add together a series of checks, a number of which,

in succession, are for the same amount. To avoid the necessity of setting up this amount prior to every stroke of the lever, I make use of means to prevent the keys from being elevated automatically at the end of the stroke and for returning the connected parts to their positions.

Any suitable locking devices that will prevent the operation of the usual automatic appliances may be employed. I prefer, however, the devices best illustrated in Figs. 2 and 11, in which 266, is a key above the key plate connected with a lever 211, swinging upon one of the shafts 200, and having an arm p , which, when the key 266, is depressed is brought above an arm p' , of the lever 622, in such a manner as to hold the latter in a position to prevent it from swinging to engage and rock the arm 219, and hence to prevent movement of the slotted bars 214, as well as the crank-levers working in conjunction therewith and operated by the keys 221. The arm 622, is rocked by means of the spring 687, (see Fig. 2) connected with the pawl 623, and with any stationary part which draws down the back end of the lever 622 and the pawl, whenever the projection k^4 , of the rack frame 311, is carried forward and away from the arm k^3 . The lever 211, is held down by the action of a forked friction spring 211^a, see Fig. 11 that bears against the side of the lever 211, and the parts are retained in position during repeated movements of the operating handle 367. After the last amount has been repeated the desired number of times, the automatic key-setting devices are unlocked by carrying the lever 211, to the position shown in full lines Fig. 11, by depressing the key 266, which rocks the shaft 207, and brings the shaft 202, against the end of the slot of a link 212, connected with the lever 211, and thereby restores the lever 211 to its normal position.

It is desirable to connect the operating handle lever 367, detachably to the shaft 300, so that the machine may not be interfered with by unauthorized persons, and it is also desirable that the lever 367 shall swing backward without operating the shaft 300, and thereby straining the connections. To this end I provide a clutch connection see Figs. 16 and 17 between the lever and the shaft in the form of clutch teeth r , upon the shaft and each beveled at one side, and provided with an abrupt shoulder on the other, and reverse clutch teeth r' , upon the shaft 300, which engage the teeth r , when the operating handle lever is pulled forward but ride over said teeth, when the operating handle lever is pushed back. The operating handle lever is provided with a pintle 352, having a conical inner end, and with a transverse slot t , adapted to receive a lip t' , upon the end of a spring actuated stud 350, carried in bearings upon the shaft 300, which stud is slotted at its upper end and guided by a short rod 351, supported in suitable bearings the slot t being so

arranged that when the pintle is pushed in to its full extent, the lip t' , will enter said slot and prevent the pintle from being drawn out, except when the same is turned quarter way round, when the locking bolt will be pushed outward, until the bottom edge of the lip t' , is in contact with the periphery of the pintle. When the parts are in this position, the operating lever may be easily withdrawn.

Without limiting myself to the precise construction and arrangement of parts shown, I claim—

1. The combination in a calculating machine, of a key-plate, a number of series of vertically movable keys extending through said plate and arranged side by side, each key having a slot, and cross-rods extending beneath the plate and passing through the slots of the keys which lie in the same transverse line, substantially as described.
2. The combination of the operating keys, the stops operated thereby, the crank-levers 217, upon which the keys rest, and which are connected with the stops, side bearings for said levers, and springs bearing against the levers and pressing them frictionally against the said bearings, substantially as described.
3. The combination of the series of levers B, and a rack connected to each lever to move longitudinally independent of said lever to a limited extent, and connecting springs to lift the racks with respect to said levers when the latter have been brought to the limit of their upward movement, substantially as described.
4. The combination of the levers B, racks movably connected therewith, to slide independently thereof to a slight extent a series of pinions 916, a cam carried by each pinion, a detent as 412 arranged to make contact with a stop as 651 upon each rack, and intermediate devices between the cams and the detents for moving each detent as the pinion gearing with the adjacent rack completes a revolution, substantially as set forth.
5. The combination with the levers B, a rack movably connected with each lever and provided with a stop, a detent bearing against said stop, a striker arranged to operate said detent, and pinions, each provided with a cam and a movable lever 413 having a bearing for the striker and another for the cam, substantially as set forth.
6. The combination of the series of strikers, a series of levers arranged to make contact with bearings upon the strikers, means for shifting the levers to release the strikers and a cross-bar 902, and independent means carrying said cross-bar for swinging the latter to carry back all of the strikers, substantially as set forth.
7. The combination with the series of keys, and with the series of bars 214 operated thereby, of a movable locking bar 203 and contact pieces upon the bars 214, substantially as set forth.
8. The combination in a calculating machine, of the keys and stops connected to be

- set thereby an operating handle and devices connected therewith for operating the different parts of the machine, a locking bar for locking the keys in their different positions, and connections between the locking bar and the operating handle for shifting the bar to lock the keys as the handle begins its movement, substantially as set forth.
9. The combination with the series of keys, the series of levers 217 and slide-bars 214, and the bearings for said levers, of a cross-bar 202, and means for automatically swinging said cross-bar to bring the same against said slide bars, substantially as set forth.
10. The combination with the keys, registering mechanism, intervening connections, and an operating handle, of a main shaft carrying the main actuating devices of the machine and a handle rock-shaft connected with the main shaft and intervening connections between the main shaft and handle rock-shaft, substantially as set forth.
11. The combination of the handle rock shaft 300 connected with the operating handle, and parallel main shaft 800, of an arm connected with a handle shaft and a yielding connection between the arm and the main shaft, substantially as described.
12. The combination of the parallel shafts 300 and 800 provided with arms and with a shaft 100 provided with arms, of reciprocating connections between the arms of the shafts 300 and 100 and a spring 880 connecting the arms of the shafts 100 and 800, substantially as set forth.
13. The combination of the shafts 100 and 800, of a lever 811 having a stud, a forked rod embracing said stud and an arm upon the shaft 100 connected with said rod, substantially as set forth.
14. The combination with the shaft 800 and lever 811 of a stud connected movably with said lever, a spring buffer bearing upon the stud and a forked rod 119 receiving said stud, substantially as set forth.
15. The combination of the shafts 300 and 100, the main shaft 800, and intermediate yielding reciprocating connections, and a dash-pot and an arm connected with said shaft 800, and with the dash-pot, substantially as described.
16. The combination of the shafts 300 and 100, the main shaft 800, and intermediate yielding connections between said shafts, and a dash-pot an arm connected with said shaft 800 and with the dash-pot, the said dash-pot being constructed of the main cylinder having a side chamber, and provided with a diaphragm having a valve, and upper and lower openings leading from the main cylinder into the side chamber, substantially as described.
17. The combination with the operating shaft connected with the handle the parts moved thereby and springs 180 for effecting the return movement of said parts, of a catch lever 527 and an arm connected with said springs arranged to engage with said catch lever and connections between the said catch lever and an operating part of the machine for releasing said catch lever as said part reaches the limit of its movement, substantially as set forth.
18. The combination with the arm 116, catch lever 527, and shaft 800, of a catch 714, striker plate 713, and connections between the catch 714 and the shaft 800 arranged to swing the said catch as the shaft terminates its movement, substantially as set forth.
19. The combination with the arm 116, connected with the springs for imparting the return movements of the parts of a calculating machine, of a catch lever 527 and a striker plate, as 713 for operating said catch and means for releasing the said striker plate, substantially as described.
20. The combination with the lifter frame I, of the series of rack levers B, and operating handle connected with the shaft 300, a main shaft 800, and yielding connections between the shafts 300 and 800 and connections between the shaft 800 and the lifter frame, substantially as set forth.
21. The combination of the lifter frame I, the shaft 800, the toggle-levers 816, 817, the lever 815 carrying the pin 859, and the slotted connecting rod 824, the slot of which receives a pin on lever 815, and the spring 884, substantially as set forth.
22. The combination with the strikers 411, the means by which the same are actuated, and the vibrating curved rack 311, of the cross-bar 902, supported intermediate of said strikers, and actuating devices, cam-lever 918, for moving said cross-bar, a spring for moving the cam-lever in one direction and a stud upon the rack to make contact with said lever to move it in the opposite direction, substantially as described.
23. The combination with the frame carrying the pinions 916, of a vibrating lever, a connecting rod and means for shifting the connecting rod to bearings upon opposite sides of the pivot of said frame, substantially as set forth.
24. The combination with the frame C and pinions 916 carried thereby, a connecting rod and means for shifting the same, to bearings on opposite sides of the pivot of the frame lever 913 to which the connecting rod is pivoted, and a shaft carrying an arm provided with a reversible pawl arranged to engage bearings upon the lever 913, substantially as set forth.
25. The combination with the lever 913, frame C, forked connecting rod having notches for engaging studs upon opposite sides of the pivot of said frame and pendent link 911, connected movably to the connecting rod and means for setting the link in position substantially as set forth.
26. The combination of the frame C, and the pinions carried thereby, the forked con-

necting rod, key 265, lever 227, and means connecting said lever and forked connecting rod, substantially as described.

5 27. The combination with the frame C, key 265 and intermediate connections, the racks and retainers 415 for the racks, and cross bar 209 contacting with the retainers and connected to be operated by said key, substantially as set forth.

10 28. The combination of the lever 227 and lever 227^a, the locking arm 621, therefor and the rack frame 311 carrying a stud for making contact with said arm, to lift the same substantially as and for the purpose set forth.

15 29. The combination with the series of pinions 916, of retainers for holding the same while out of gear, and means for swinging the retainers to engage the pinions as the latter are swung in either direction, substantially as set forth.

20 30. The combination with the series of pinions 916, carried by a frame, a series of teeth carried by arms or levers pivoted to the shaft of said frame, a lever 917, for operating the frame, and having a beveled end engaging a beveled edge upon said frame, substantially as set forth.

25 31. The combination with the frame C, and its operating devices, a spring-controlled lever 917 engaging the frame when at the limit of its movement in either direction, and an automatic locking device for holding said lever after the frame reaches either position, substantially as set forth.

30 32. The combination with the keys, the cross-bar 202, and connections for restoring the position of the keys, the key 265, and con-

nections between said key and the cross-bar, substantially as set forth.

33. The combination with the bar 202, vi- 40
brating arms 219, supporting the same and one provided with a stud, the rock-shaft 600 supporting an arm and a spring pawl upon said arm arranged to engage said stud, substantially as set forth. 45

34. The combination with the main operating keys, the cross-bars 202, and connections for restoring the positions of the keys, of the key 265, the frame C, and its locking devices, and connections between such devices and 50
said key 265, substantially as described.

35. The combination of the handle-lever formed or provided on its hub with teeth *r*, beveled on one side and provided with an abrupt shoulder on the other, said lever be- 55
ing provided with a slotted conical pintle, the shaft 300, having reverse teeth *r'*, and the spring actuated stud provided with a lip for entering the notch of the pintle, substantially as shown and for the purpose described. 60

36. The combination with a series of keys and parts shifted thereby, and lugs arranged upon said parts, of a movable locking bar 203 arranged to occupy a position on either side of said lugs when at the limit of their differ- 65
ent positions, substantially as set forth.

In testimony whereof I have signed my name to this specification in the presence of two subscribing witnesses.

WILLIAM S. BURROUGHS.

Witnesses:

E. PARMER,

A. H. B. OLIVER.