

W. T. ODHNER.
CALCULATING APPARATUS.

No. 514,725.

Patented Feb. 13, 1894.

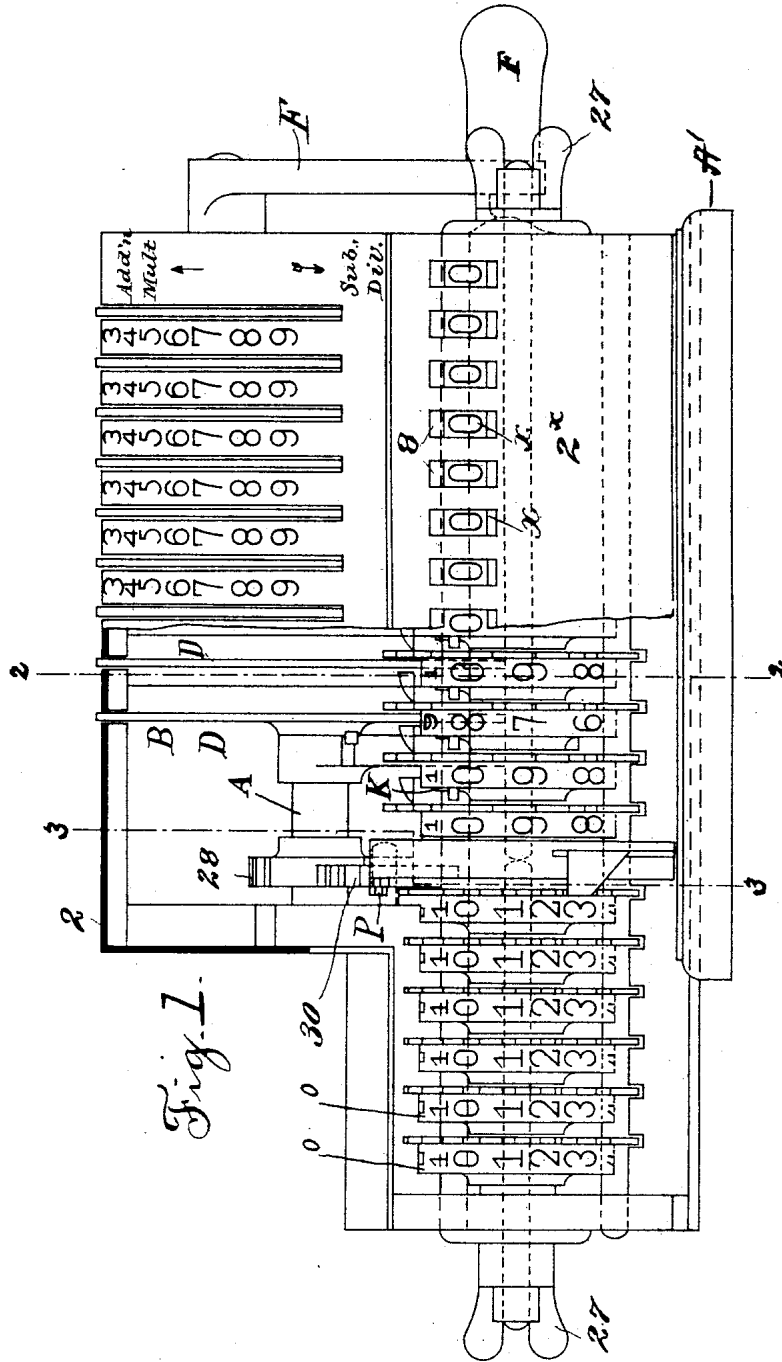

Fig. 1.

Witnesses
 Chas. B. Chandler
 Arthur P. Jenkins.

Inventor
 Willard Odhner.
 By Chas. F. Lander
 Attorney.

W. T. ODHNER.
CALCULATING APPARATUS.

No. 514,725.

Patented Feb. 13, 1894.

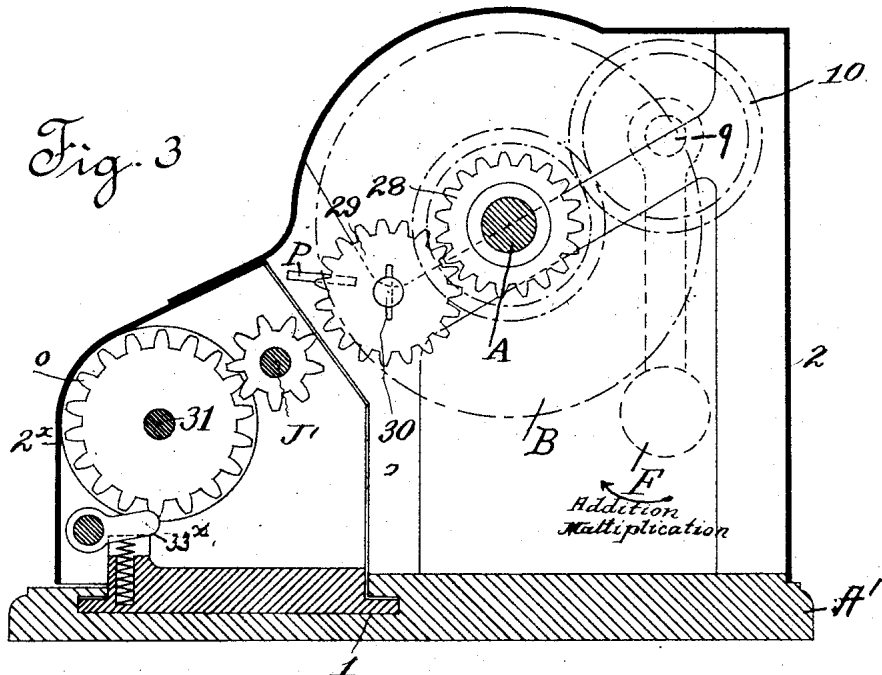
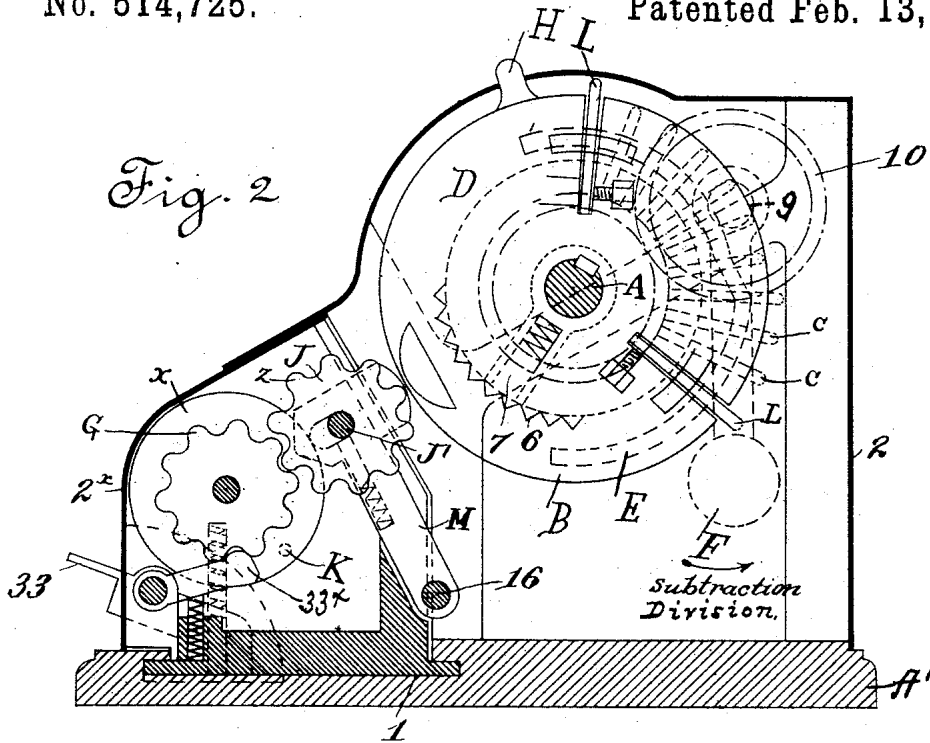

Witnesses
 Chas. B. Chandler
 Arthur P. Jenkins

Inventor
 Willgodt Odhner
 By Charles T. Landley
 Attorney.

(No Model.)

5 Sheets—Sheet 3.

W. T. ODHNER. CALCULATING APPARATUS.

No. 514,725.

Patented Feb. 13, 1894.

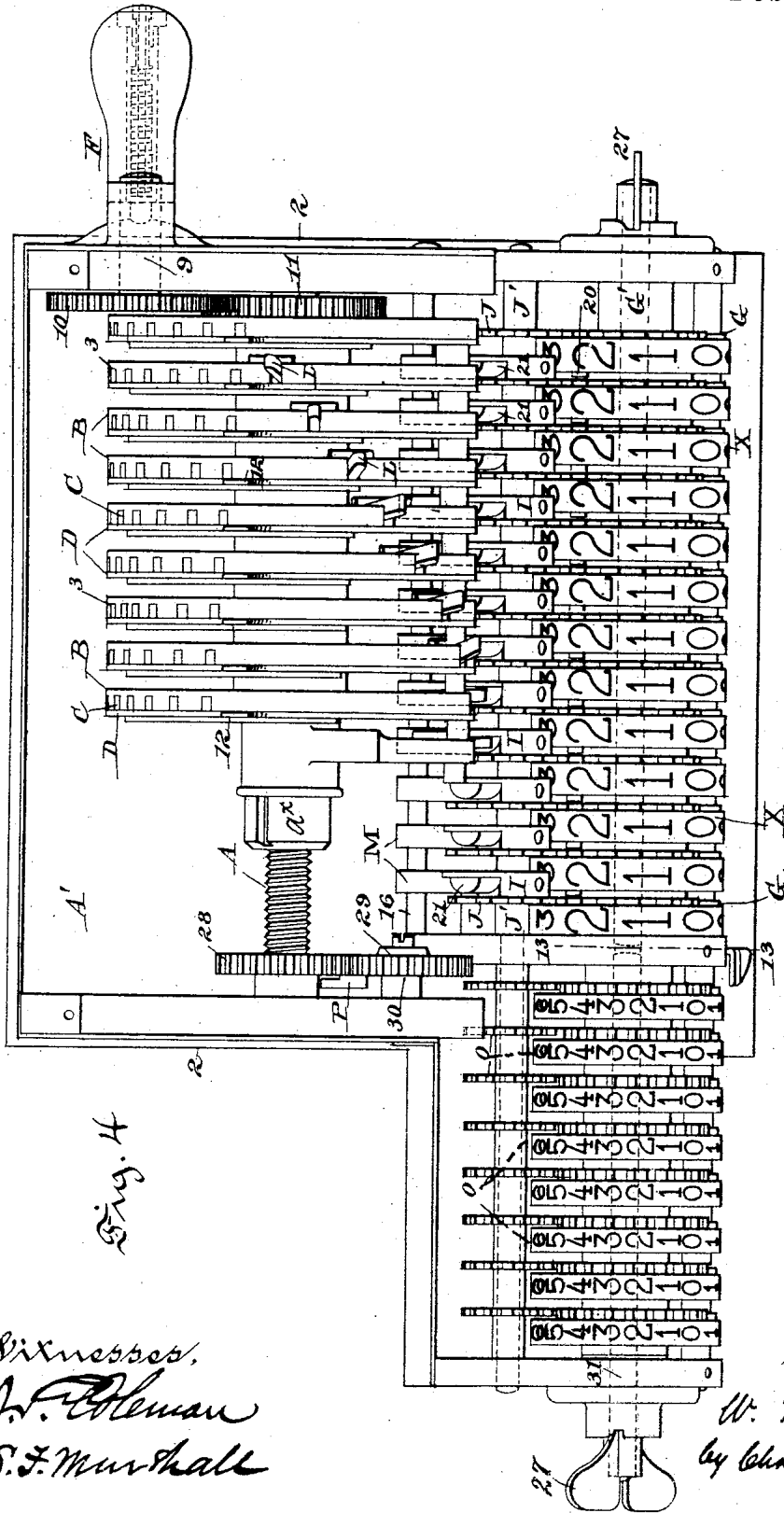

Fig. 4

*Witnesses,
J. P. Coleman
S. F. Marshall*

*Inventor
W. T. Odhner
by Chas. S. Landis*

att'y.

W. T. ODHNER.
CALCULATING APPARATUS.

No. 514,725.

Patented Feb. 13, 1894.

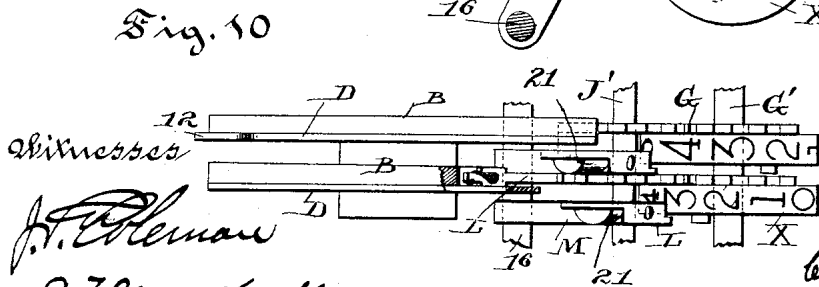
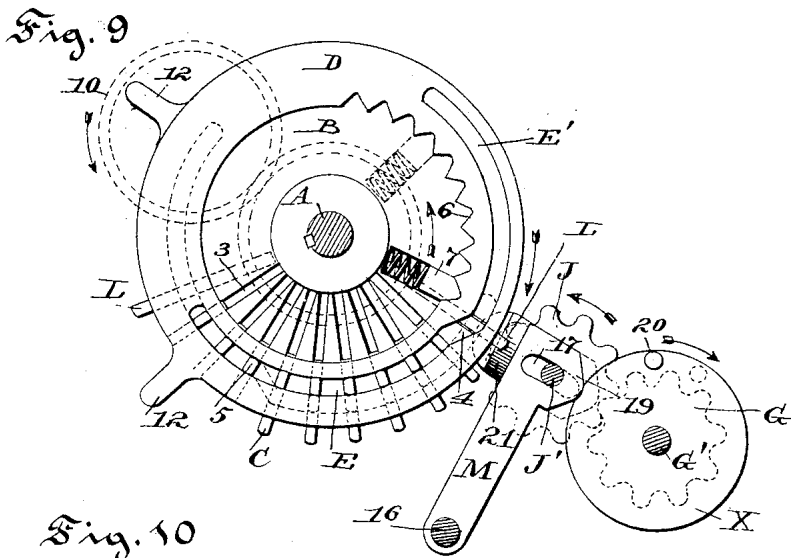
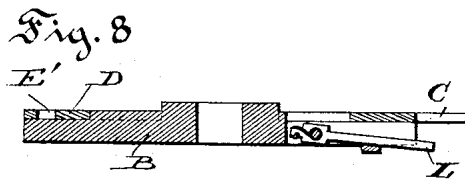
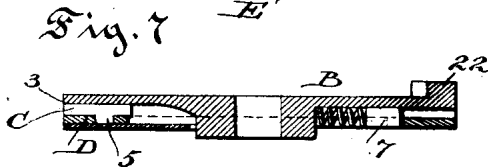
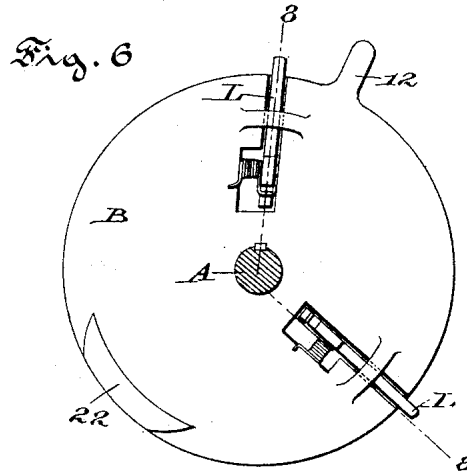
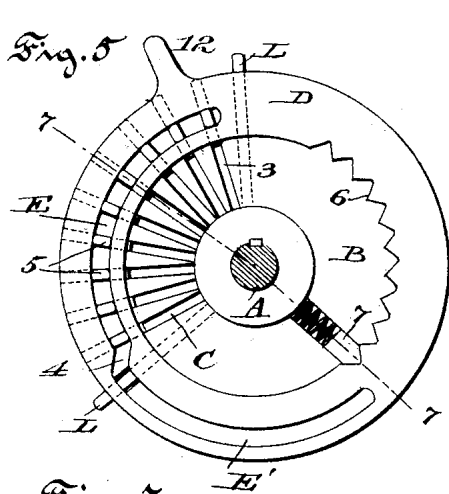

Witnesses
J. F. Coleman
S. F. Marshall

Inventor
W. T. Odhner,
 by
Chas. S. Landers,
 atty.

(No Model.)

5 Sheets—Sheet 5.

W. T. ODHNER.
CALCULATING APPARATUS.

No. 514,725.

Patented Feb. 13, 1894.

Fig. 11

Fig. 12

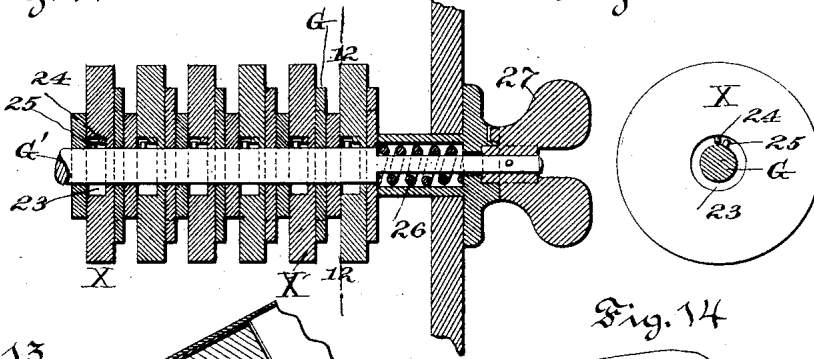
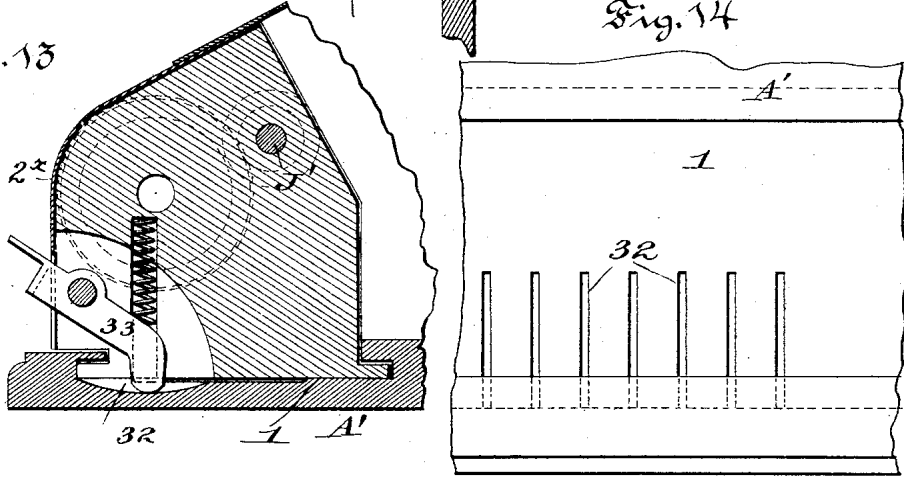

Fig. 13

Fig. 14



Witnesses

J. Coleman
S. F. Marshall

Inventor

W. T. Odhner,
by Chas. S. Landers.

att'y.

UNITED STATES PATENT OFFICE.

WILLGODT THEOPHIL ODHNER, OF ST. PETERSBURG, RUSSIA.

CALCULATING APPARATUS.

SPECIFICATION forming part of Letters Patent No. 514,725, dated February 13, 1894.

Application filed January 3, 1893. Serial No. 457,179. (No model.) Patented in France August 29, 1890, No. 207,932; in Luxemburg August 30, 1890; in Belgium September 15, 1890; in Sweden September 26, 1890, No. 3,264; in Norway October 9, 1890, No. 2,117; in Austria-Hungary December 15, 1890, No. 40 and No. 3,843, and in England August 29, 1891, No. 13,700.

To all whom it may concern:

Be it known that I, WILLGODT THEOPHIL ODHNER, a subject of the King of Sweden and Norway, residing in St. Petersburg, in the Empire of Russia, have invented a new and useful Calculating Apparatus, (for which I have obtained patents in Norway October 9, 1890, No. 2,117; in Austria-Hungary December 15, 1890, No. 40 and No. 3,843; in Belgium September 15, 1890; in France August 29, 1890, No. 207,932; in Luxemburg August 30, 1890; in Great Britain August 29, 1891, No. 13,700, and in Sweden September 26, 1890, No. 3,264,) of which the following is a specification.

My invention relates to improvements in calculating machines; and the object is to provide a machine for adding and subtracting numbers, and similar arithmetical purposes or uses, which is of simple construction, accurate in results, and easy of manipulation.

I have fully and clearly illustrated the invention in the accompanying drawings, wherein—

Figure 1 is a plan view of the machine with the plate or cover having the tabulations, &c., thereon. Fig. 2 is a transverse vertical section on the line 2—2. Fig. 3 is a similar section taken on the line 3—3, of Fig. 1. Fig. 4 is a plan view of the machine showing the mechanism; the cover-plates being removed. Fig. 5, is a side view of one of the calculating-wheels, showing the sliding-rods or pins, and the annulus, with the means for holding the annulus in a set position. Fig. 6 is a reverse side view of one of the calculating wheels. Fig. 7 is a sectional view taken on the line 7—7 of Fig. 5. Fig. 8 is a section taken on the line 8—8 of Fig. 6. Fig. 9 is a detail section showing the calculating and registering wheels and the intermediate mechanism. Fig. 10 is a detail plan view of the same mechanism shown in Fig. 9. Fig. 11 is a longitudinal section of a portion of the registering wheels and their shaft. Fig. 12 is a cross section taken on the line 12—12 of Fig. 11. Fig. 13 is a section on line 13—13 of Fig. 4. Fig. 14 is a plan view of a part of the base-plate showing the recesses or kerfs which are engaged by the latch to hold the sliding-table in a set position.

A' designates the bottom of the box or casing having a flanged-way 1 in it to take and hold the casing of the registering mechanism. On the bottom A' is sustained and secured a suitable casing 2, adapted to sustain and surround the calculating-mechanism.

On a suitable shaft A, journaled in bearings at the ends of the machine, are fixed calculating wheels B arranged on the shaft adjacent to each other, substantially as indicated in the drawings. The wheels B are each provided with a group of nine radially disposed slots 3, in which are fixed movable pins or rods C, adapted to be moved back and forth lengthwise so that in their outward movement they may be moved to project beyond the perimeter of the wheel. This movement of the rods C is effected by means of an annulus D mounted at the side of the calculating-wheel, and provided with concentric slots E, E' opening into each other by a curved or inclined step 4 in which shoulders or lugs 5 on the pins C engage and are thrown out and depressed by turning the annulus. To hold the annulus in any position to which it may be turned to the extent desired, a series of notches 6, is cut in the inner edge thereof, which are engaged by a spring-actuated plug 7 substantially as shown in Figs. 5 and 6 of the drawings. When any one or number of pins C is made to project as mentioned on turning the crank F the projecting pins engage with tooth-wheels J see Figs. 2 and 9 journaled on a shaft J' which wheels in their order engage with the toothed registering-wheels G, having disks x connected to them, with figures from 0 to 9 on their circumferential faces. The figures on the disks x may be rendered visible through openings 8, in the cover 2^x of the registering-disks, indicating thereby, after turning the calculating-wheels, the number the machine has added or otherwise been moved to.

The crank F is mounted on a journal 9 carrying a gear-wheel 10 which meshes with a pinion 11, on the shaft A which carries the calculating-wheels B.

The annuli D have finger pieces 12, which project through slots 13, in the cover of the case, as shown, so that they may be conveniently operated. In order that the annuli D,

may be turned to throw out the desired number of the pins C, there are figures 14 indicated at the sides of the slots, as shown in Fig. 1 of the drawings. This arrangement has the advantage that the annuli D may be made much simpler, and require less space between the calculating-wheels, and the figures easily observed and always visible.

The shaft A is shown threaded in Fig. 4 of the drawings and has fitted on it a holding-nut a^x , to clamp the wheels on the shaft.

The intermediate wheels J transmit rotative motion to registering wheels G through the engagement of the pins of the calculating wheels. These wheels J insure the exact movement of the registering-wheels, G and prevent the latter from being moved too far during a rapid rotation. To carry the "tens" to the next column of value a series of arms M is fulcrumed on a rod 16, the arms being formed with heads or shoulders I on their upper ends, formed with a slot 17 through which a shaft J' is loosely projected. The rear ends of the shoulders I are formed with a cam surface 19 which is engaged by a pin 20, on the registering-wheels, which engagement throws the arm M with the shoulder I forward with the front end projecting between the calculating-wheels B. On the side of the forward end of these shoulder-pieces is a cam-surface 21 which when the shoulder piece is moved forward lies close to the next adjacent intermediate-wheel of higher order, as shown in Fig. 10 of the drawings.

In each calculating-wheel B are two pins or teeth L the ends of which extend beyond the peripheries of the wheels, and stand normally to one side, so as not to be in the same line of rotation with the pins C of the calculating-wheels. Normally these pins L stand to run between the intermediate wheels J but when the shoulder pieces I are moved forward between two of the wheels B, the pins L are deflected to run on the line of rotation of the pins C, by the engagement with the cam face 21, and the end of the pin L then engages the tooth of the adjacent intermediate wheel J and turns that the distance of one tooth, and thereby turns the wheel G one tooth and registers the "ten." To return the shoulder-pieces to their normal position a projecting piece 22, see Figs. 6 and 7, is fixed to each calculating wheel which engages the end of the shoulder-pieces and pushes them back into position.

The registering-wheels G are mounted to turn on a shaft G' and have annular recesses 23 in the hubs, in which is a lug 24, which may be engaged by a pin 25, on the shaft. The shaft G' has a limited longitudinal movement in its bearings through the agency of a spring 26, and snap finger-piece 27 substantially as shown in Fig. 11 of the drawings, so that when the registering wheels have been moved, to register any result, the shaft may be moved lengthwise and may be turned by

the finger-piece and the wheels be reset to zero.

On the shaft A is a gear wheel 28, meshing with a gear wheel 29 on a stud bearing 30 and on the wheel 29 is an arm P which engages with one of the gears o on the shaft 31 and registers the number of rotations made by the crank F and calculating wheels B. The gears o are mounted on their shaft similar to the main registering-wheels. The directions in which the crank F is to be turned to produce the certain results have been indicated by arrows on Figs. 2 and 3 of the drawings.

To operate the machine for addition the following example is stated: Add 75,384, 6,278 and 9,507. Having drawn the finger-pieces of the annuli to indicate 75,384 the crank is turned one rotation whereupon these integers are thrown into view in the registering mechanism, then turn the finger pieces to 6,278 and 9,507 in succession and the sum or 91,169 will be registered on the wheels G. Examples in subtraction may be done in the same way except the rotation of the crank is reversed. It will be seen by reference to the drawings that the registering-wheels G are mounted in a frame which slides longitudinally in the way 1 in the bottom of the case; this is to aid in solving examples in multiplication and division. In the bottom of the way are recesses or stops 32 which are placed a distance apart of two registering-wheels, and are engaged by a spring catch 33 which holds the case of the registering wheels in any set position. In Figs. 2 and 3 this spring-catch 33 is shown in modified form, being an arm 33^x , extended between two of the registering-wheels.

The following illustration will show the operation in multiplication: Multiply 87,659 by 6,034. Draw the finger pieces of the annuli to register the multiplicand, then turn the crank four times, then move the register case one stop to the right and turn the crank three times, then move the register case two stops to the right and turn the crank six times, and the product 528,934,406 is registered and the multiplier 24 will be registered on the disks o .

To operate the machine in division the following example is given:—Divide 8,450 by 26:—The dividend 8,450 is first registered on the disks x and the figure 1 appears on the units disk of the disks o indicating that the crank has been turned one revolution. The disks o are then turned so that naughts are registered. The finger-pieces of the calculating-wheels are then turned to zero and then moved to indicate the divisor 26; the register-case is then moved to the right two lines or spaces, bringing the divisor 26 over the numbers 84 of the dividend. The handle is then turned three times in the direction of the indicating word "Div." or until the remainder is less than 26; the registering-case is then moved one space to the left and the

handle turned in the same direction as before two rotations until the remainder shows less than 26; the registering-case is then moved again one space to the left and the handle turned in same direction five times, or until the remainder is shown less than 26. The quotient 325 will appear registered on the disks o and the remainder (in this instance nothing) will appear registered on the disks α .

What I claim is—

1. The combination with the calculating-wheels, formed with a radial slot, a pin in the slot resting normally to one side, the intermediate wheels, the registering wheels, shouldered arms between the intermediate wheels, having their lower ends fulcrumed on a shaft and their heads formed with cam-surfaces on the side, and a slot to take the shaft of the intermediate wheels, means on the registry

mechanism to push the arms forward whereby the pin in the calculating wheel is moved to vertical position to engage the next adjacent intermediate wheel, as and for the purpose specified.

2. The combination with the shaft, the calculating-wheels, of a gear wheel thereon, a gear wheel mounted in mesh with the other gear and having an arm, and a series of registering wheels arranged to be engaged by the said arm, whereby the rotations of the calculating wheels are registered.

In witness whereof I have hereunto signed my name in the presence of two subscribing witnesses.

WILLGODT THEOPHIL ODHNER.

Witnesses:

D. A. LORING, Jr.,

W. FRISK.