

(No Model.)

5 Sheets—Sheet 1.

F. WOODBRIDGE.
CASH REGISTER AND RECORDER.

No. 585,996.

Patented July 6, 1897

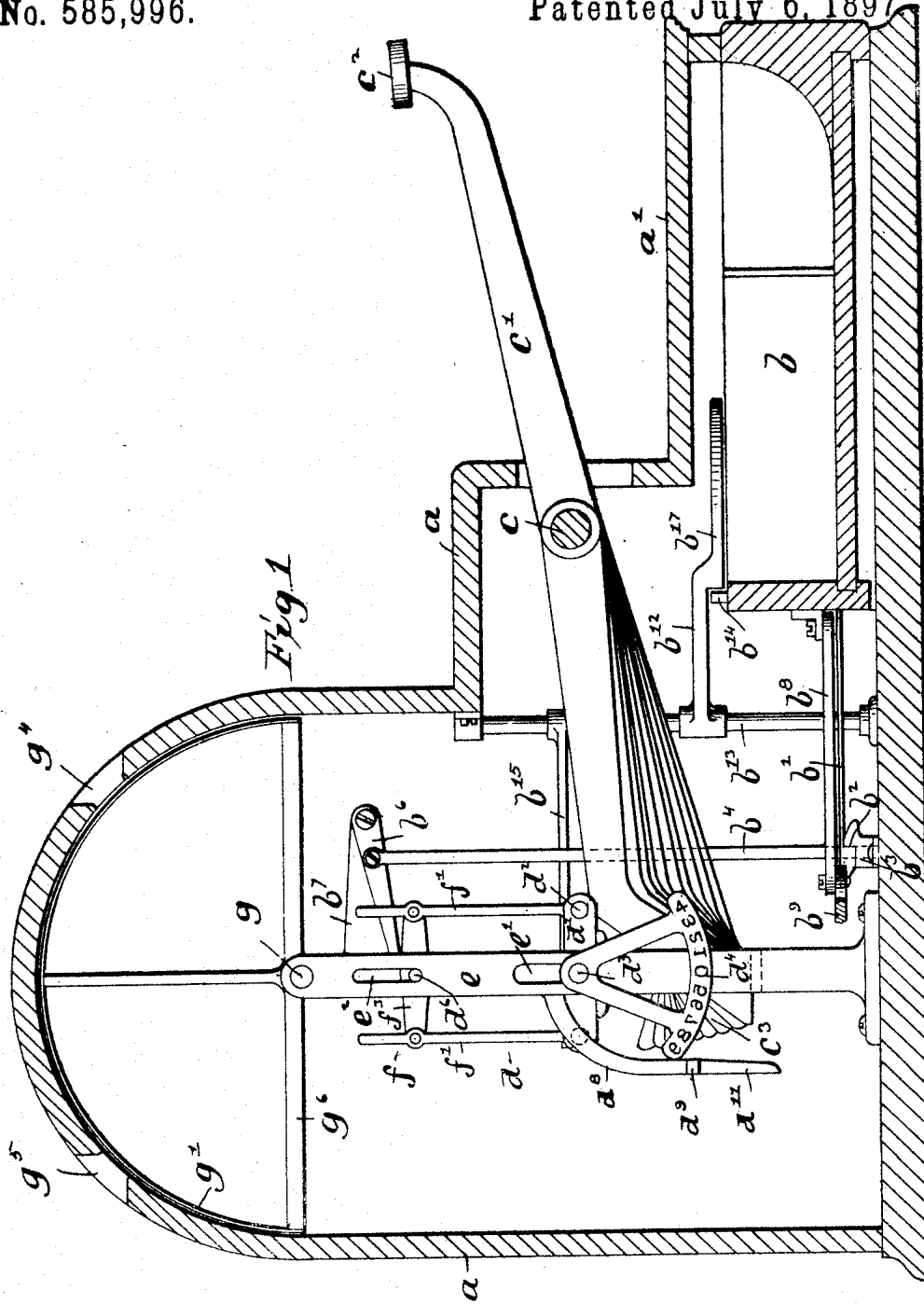

Witnesses
G. M. Bradley
Chas. J. Welch

Inventor
Frank Woodbridge
 By his Attorney
Paul A. Wiley

(No Model.)

5 Sheets—Sheet 2.

F. WOODBRIDGE.
CASH REGISTER AND RECORDER.

No. 585,996.

Patented July 6, 1897.

Fig. 2

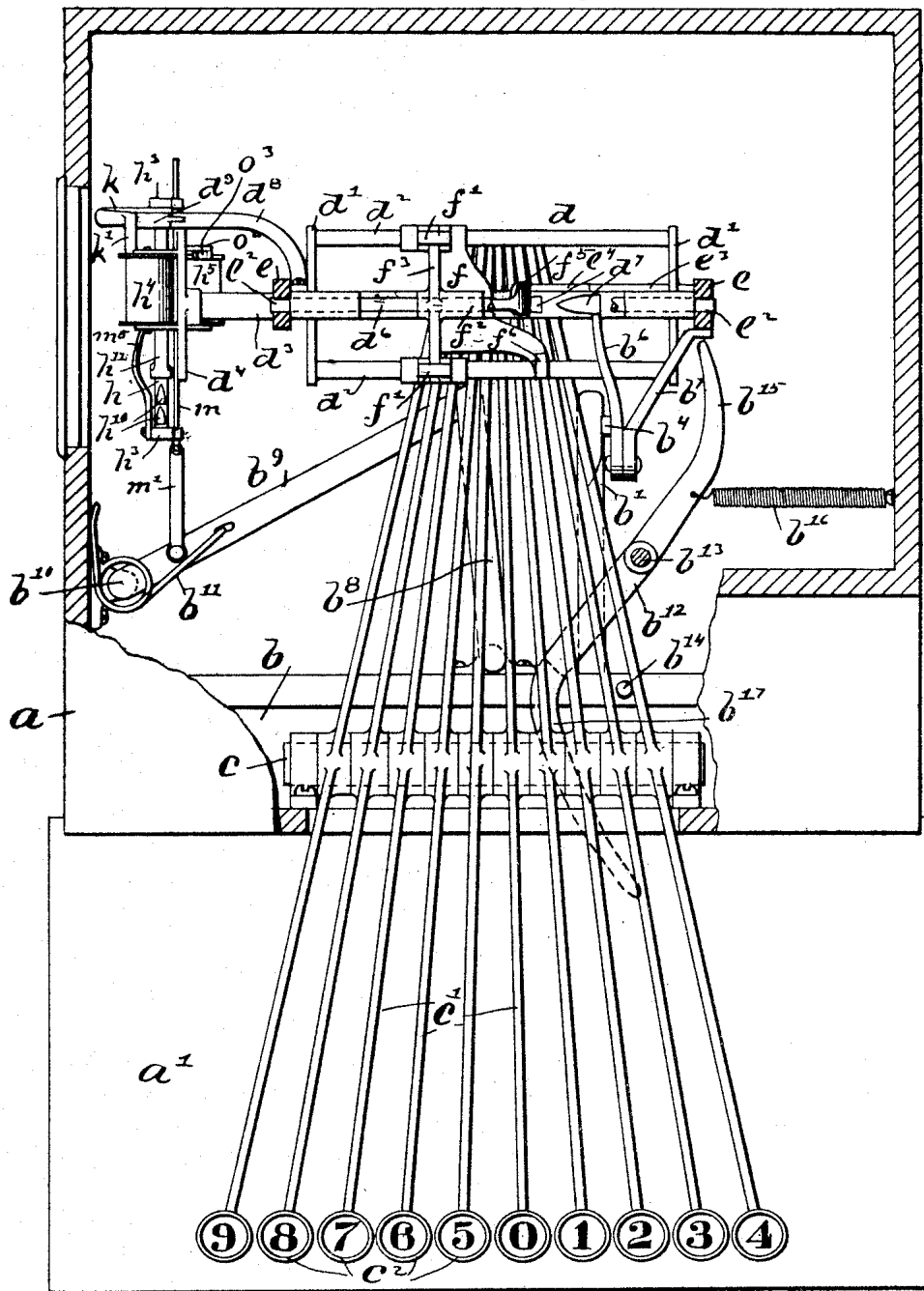

Witnesses
 J. M. Bradley
 Chas. J. Welch

Inventor
 Frank Woodbridge
 By his Attorney
 Paul A. Atkey

F. WOODBRIDGE.
CASH REGISTER AND RECORDER.

No. 585,996.

Patented July 6, 1897.

Fig. 3

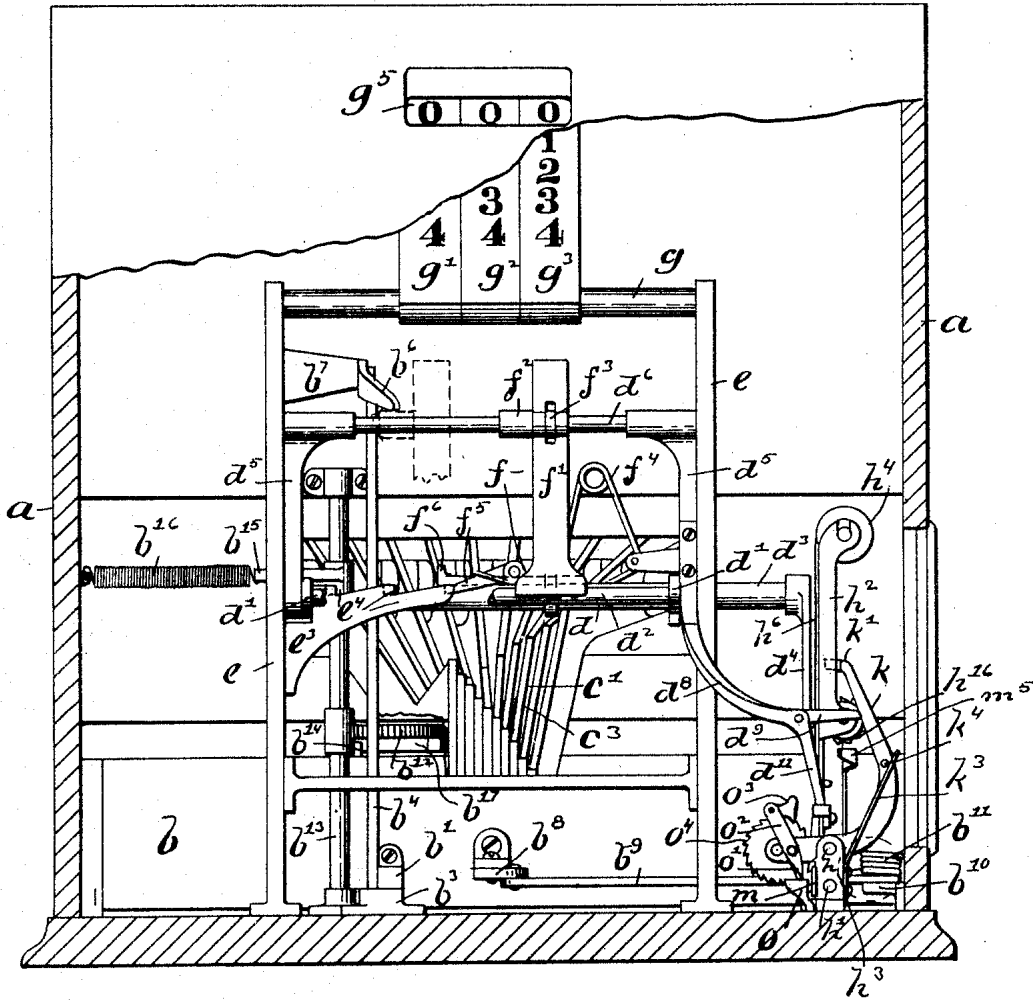

Witnesses
G. M. Bradley
Chas. J. Meloh

Inventor
Frank Woodbridge
 By *his* Attorney
Paul A. Wiley

F. WOODBRIDGE.
CASH REGISTER AND RECORDER.

No. 585,996.

Patented July 6, 1897.

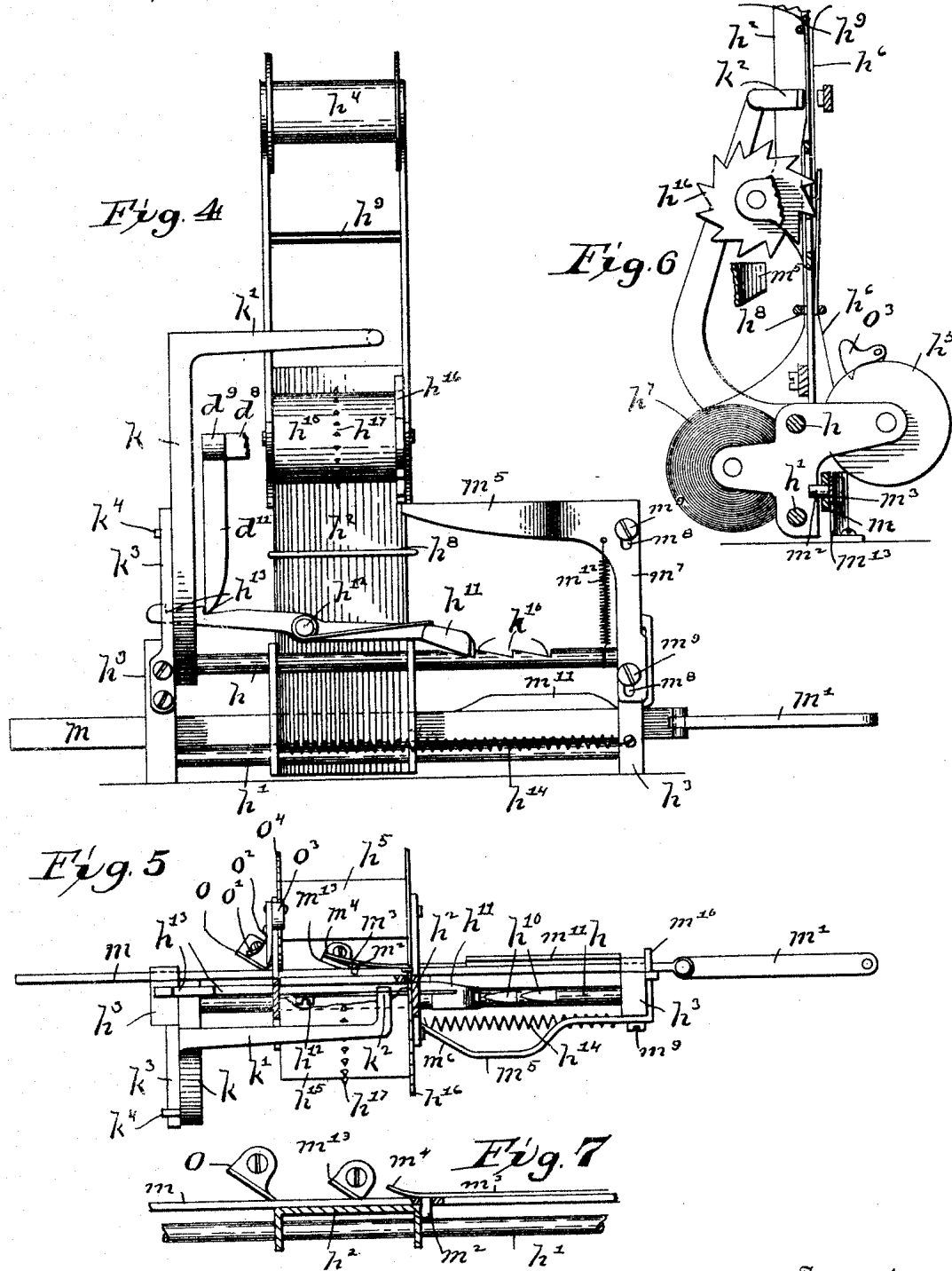

Witnesses
J. Milgriddle
Chas. J. Welch

Inventor
Frank Woodbridge
 By his Attorney
Paul A. Wiley

F. WOODBRIDGE.
CASH REGISTER AND RECORDER.

No. 585,996.

Patented July 6, 1897.

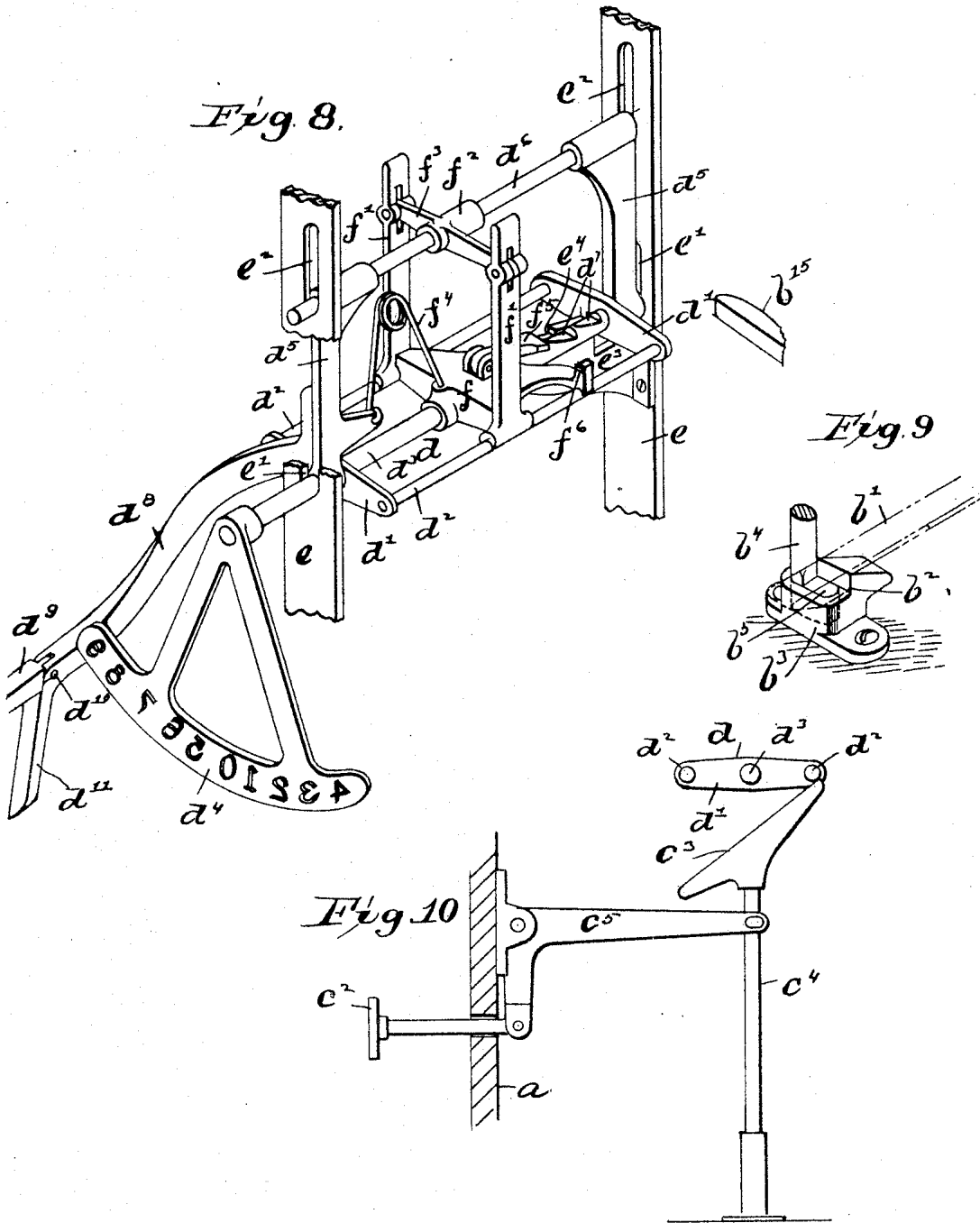

Witnesses
G. M. Ridley
Chas. J. Vial

Inventor
Frank Woodbridge
 By his Attorney
Paul A. [Signature]

UNITED STATES PATENT OFFICE.

FRANK WOODBRIDGE, OF INDIANAPOLIS, INDIANA.

CASH REGISTER AND RECORDER.

SPECIFICATION forming part of Letters Patent No. 585,996, dated July 6, 1897.

Application filed September 8, 1896. Serial No. 605,207. (No model.)

To all whom it may concern:

Be it known that I, FRANK WOODBRIDGE, a citizen of the United States, residing at Indianapolis, in the county of Marion and State of Indiana, have invented certain new and useful Improvements in Cash Registers and Recorders, of which the following is a specification.

My invention relates to improvements in cash registers and recorders; and my invention consists in the various constructions and combinations of parts hereinafter described, and pointed out in the claims.

In the accompanying drawings, Figure 1 is a sectional elevation of a machine embodying my invention. Fig. 2 is a plan view of the working parts with the casing and some of the parts shown in section. Fig. 3 is a rear elevation of the operating parts with a portion of the casing broken away and shown in section in order to show the interior arrangement. Fig. 4 is a side elevation of the recording mechanism. Fig. 5 is a plan view, partly in section, of the same. Fig. 6 is an end elevation of a portion of the same, and Fig. 7 is a detail view. Fig. 8 is a perspective view of the intermediate actuating devices for the indicators and recording device. Fig. 9 is a detail view of the drawer-locking mechanism, and Fig. 10 is a modification.

Like parts are represented by similar letters of reference in the several views.

In the said drawings, *a* represents an outer casing, which may be of any suitable size or shape. The front of the casing is preferably extended, as shown at *a'*, and there is located with this extension a cash-receptacle *b*, preferably in the shape of a drawer, adapted to slide out of and into the lower part of the casing or its extension *a'*. Above the drawer *b* and preferably pivoted on a common supporting rod or bar *c* is a series of key-levers *c'*, having numbered button *c²*, and which may be termed the "cash-keys." These key-levers *c'* extend inwardly, preferably at an angle, toward the center, so that their inner ends are brought close together and with small compass. The ends of the levers are all formed at different angles, as shown at *c³*, and they normally rest below a pivoted vertical movable frame *d*. This frame *d* is preferably formed of cross-bars *d'* and lon-

gitudinal rods *d²* *d³*, which extend from the respective ends of one cross-bar to the corresponding ends of the other cross-bar. The bars *d'* are secured to a central shaft *d³*, which in turn is seated in slotted openings *e'*, formed in the upright frame-pieces *e*, secured to the inside of the casing or forming a part of an interior frame of the machine. The shaft *d³* carries on one end a sector *d⁴*, which is numbered around on the face near the outer periphery with numbers corresponding to the numbers on the cash-keys.

One of the prime objects of my invention is to provide means for registering a number composed of several denominations—such as units, tens, hundreds, &c.—with one series of cash-keys which are numbered from "0" to "9," respectively, and I accomplish this in the following manner: There is mounted loosely on the shaft *d³* of the frame *d* a movable head or traveler *f*, which has extending upwardly therefrom vertical arms *f'*, which preferably have bearings at their lower ends, respectively, on the longitudinal frame-rods *d²*. Above the shaft *d³* and connected thereto by suitable standards *d⁵* is a rod or shaft *d⁶*, the respective ends of which are extended through slotted openings *e²* in the vertical frame-pieces *e* in line with and above the openings *e'*, in which the shaft *d³* is seated. There is journaled loosely on the rod *d⁶* a sleeve *f²*, from which project arms *f³* *f³*, pivotally connected to the vertical arms *f'* of the traveling head *f*. A spring *f⁴*, connected at one end to one of the standards *d⁵* and at the other to the traveling head *f*, tends to move said head longitudinally on the shaft *d³* and the longitudinal bars *d²*. A pivoted pawl *f⁵*, however, on said head, by engaging in notches *d⁷* on the shaft *d³* tends to hold said traveler from being moved longitudinally in the frame *d* by the spring *f⁴*, except in the manner hereinafter described.

Arranged in the top of the casing and journaled on a suitable frame-rod *g* in the top of the standards *e* are the indicators *g'* *g²* *g³*. These indicators are preferably made in the form of a half-circle and are provided with numbers from "0" to "9," inclusive, which are adapted, as the indicators are moved, to be brought successively opposite an opening *g⁴* in the upper part of the casing. These in-

dicators are preferably provided with a double series of numbers, and two openings g^1 and g^2 on opposite sides of the casing are preferably provided, so that the numbers may be read from either the front or rear of the machine. In the normal position of the machine the vertical arms f' of the traveling head f stand directly under the first indicator or indicating-wheel, each of said indicators being provided at the bottom with a base or cross-bar g^6 . The indicators g^1 , g^2 , and g^3 are balanced on the shaft g and are adapted to remain in any position of adjustment which they may assume in the operation of the machine until moved to a different position. Now from the description this far it will be seen that when any lever of the cash-keys is operated by depressing the forward end the rear end will be elevated so as to bring the inclined portion c^3 thereof in contact with the longitudinal bars d^2 . If the lever is inclined in one direction, it will strike the front bar first, and if in the other direction it will strike the rear bar first; but in either case the shaft d^3 will be turned until the said bars assume the same angular position as the end of the key depressed. The upper end of the projecting arms f' will also assume a position in a plane parallel with that of the bars. A further movement of the lever will cause the frame d , with the traveling head f and vertical arms f' , to be raised vertically, the shafts d^3 and d^6 , respectively, rising in the slotted openings e^1 and e^2 in the frame-pieces e . The ends of the vertical arms f' will be brought in contact with the first series of indicators—that is, in the present case the hundreds indicator—and the lower cross-bar of said indicator will be turned to an angle corresponding to the angle of the lever, and this will bring the number on the indicator corresponding to the number of the key depressed opposite the display-openings.

As before stated, the pawl f^5 , engaging with one of the notches d^7 on the shaft d^3 , prevents the traveling head f from moving longitudinally on said shaft. It should be stated, however, that there is secured to one of the frame-pieces e a stationary bar e^3 , having a series of notches e^4 corresponding to the notches d^7 on the shaft, except that the notches e^4 stand slightly in advance of those d^7 , and in the normal position the pawl f^5 rests in the first notch or against the end of the bar e^3 . As soon as the frame d is raised, however, the pawl, being withdrawn from the end of the bar e , will drop into the first notch d^7 and prevent further movement of the traveling head while the frame is in an elevated position. As soon as the frame is released, however, by releasing the key-lever it drops to its normal position, and the pawl f^5 , contacting with the bar e^3 , is withdrawn from the first notch d^7 and enters the first notch e^4 , thus advancing the traveling head a distance equal to the width of one of the indicators. The indicator g^3 , however, representing hun-

drreds, remains in the position to which it has been moved by the vertical arms f' . It will be seen now that if the same or another key is again depressed the operation will be repeated, but the vertical arms or standards f' being opposite the second or tens indicator g^2 this indicator will be moved. As the frame d rises, the pawl will be released from the notch in the stationary bar and engage the notch in the shaft and advance slightly, so that when the frame is dropped it will drop on top of the stationary bar and be thus withdrawn from the notch d^7 , which will permit the head to advance the distance of another notch on the bar d^3 . This brings the vertical arms f' under the third or units indicator, and, the operation being repeated, the units indicator will be set to correspond to the third key depressed.

Since in my improved device the drawer is opened only after the operation of the units-indicator, which in this case would be the third in the series, means are provided for releasing the drawer when the frame is elevated the third time. This is accomplished as follows: The drawer is provided at the rear with a spring-catch b^1 , which is adapted to engage with a shoulder b^2 on a stationary catch b^3 , secured within the casing. This catch b^3 is provided adjacent to the face of the shoulder or lug b^2 with a pocket or opening in which is seated the end of a rod b^4 , having a laterally-projecting finger b^5 , which normally rests under a spring-catch b^6 , one end of which is pivoted to a suitable support b^7 on one of the frame-pieces e and the other end projected in proximity to the shaft or bar d^6 , on which travels the sleeve f^2 . The end of the arm or lever b^6 is sufficiently removed from the shaft or bar d^6 to permit a vertical movement of said bar, but when the traveling head is moved laterally, so as to bring the vertical arms f' in line with the units-indicator, the sleeve f^2 will come under the end of the arm b^6 , and when the frame d is elevated by the depression of a key the arm b^6 will be raised by said sleeve, thus raising the rod b^4 , bringing the finger b^5 in contact with the spring-catch b^1 , and raising it from engagement with the shoulder b^2 .

There is connected to the rear of the drawer, by means of a link b^8 , a spring-actuated lever b^9 , pivoted at b^{10} to the side of the casing, and so connected to a spring b^{11} that when the drawer is released the spring, acting against the arm, will, through the medium of the link b^8 , cause the drawer to be opened.

It will thus be seen that any desired number may be indicated by successively operating the same series of keys, always beginning with hundreds and ending with units, and when the units are indicated the drawer will be opened.

Means are provided for returning the parts to their normal positions as the drawer is closed, and this is accomplished through the medium of a cam-lever b^{12} , mounted on a

suitable shaft b^{13} and extending in proximity to the top of the drawer and adapted to be engaged by a pin or projection b^{14} in the drawer as the drawer is closed. The shaft b^{13} is further provided with an arm b^{15} , which extends in opposite directions and in line with a suitable lug or projection f^6 on the traveling head f , a spring b^{16} being connected to the arm b^{15} to return it to its normal position after being moved by the closing of the drawer. It should be noted that the curved or cam portion b^{17} of the arm or lever b^{12} is in a different plane from the main body thereof, so that as the drawer is closed the projection b^{14} will release said lever and permit the same to be returned to its normal position by the spring b^{16} after the drawer is completely closed. The contact between the projection b^{14} and the end of the lever b^{12} causes the arm b^{15} to engage in the traveling head and move it longitudinally in its frame d until it reaches its normal position, when the machine is again ready for operation, the indicators remaining in the position in which they were last set. As the projection b^{14} reaches the end of the curved or cam-shaped portion of the lever b^{17} said lever is released by said projection and is returned to its normal position by the spring b^{16} . This spring b^{16} is adapted to act to a limited extent in both directions—that is to say, when the lever is in the normal position the spring permits the lever to move backward sufficiently to allow the projection b^{14} to pass the end of the cam-shaped portion thereof as the drawer is opened, so that it will engage the opposite side of the lever as the drawer is closed.

To provide for registering or recording the amounts thus indicated, I employ a shifting recording device adapted to cooperate with the numbered segment d^4 on the end of the shaft d^3 , and this is constructed and arranged as follows: Arranged on suitable guiding-rods h and h' at one end of the casing adjacent to the numbered segment d^4 is a traveling frame h^2 , the guiding-rods h h' being supported at each end in suitable standards h^3 , which may form a part of the main frame or be secured directly to the casing. This frame h^2 is extended upwardly and is provided at the top and bottom with rollers h^4 h^5 , upon and from which an ordinary inking-ribbon h^6 is adapted to be wound and unwound. The frame also carries a suitable paper-reel h^7 upon the opposite side thereof from the ribbon-roller h^6 , and the ribbon and paper, respectively, from said rollers are extended upwardly through suitable guides h^8 and h^9 , so as to pass parallel across the face of the numbered segment.

There is secured on the rod h a curved lever k , which is provided at the upper end with a laterally-projecting arm k' , having at the end a hammer k^2 , which is adapted as the segment d^4 is raised vertically to stand in line with the respective numbers on said seg-

ment. A spring k^3 , secured to one of the standards h^3 and operating against a projection k^4 on the lever k , serves to impart motion to said hammer, in the manner hereinafter more fully described.

The guide-rod h for the traveling frame h^2 is provided with a series of notches or teeth h^{10} , which are adapted to be successively engaged by a pivoted pawl-lever h^{11} , pivoted at h^{12} to the traveling frame h^2 . This pawl-lever h^{11} is extended beyond its pivotal support, and the projecting end is also provided with ratchet-teeth or notches h^{13} .

There is connected to one of the standards d^5 of the vertically-moving frame d a laterally and downwardly curved arm d^8 , having pivoted thereto a finger d^9 , which is free to move upwardly with relation to said arm, but may not move downwardly beyond the horizontal position, being held in this position by shoulders d^{10} , which engage the arm d^8 at the joint or pivoted connection, as shown in Fig. 8. Below this joint or pivoted connection the arm d^8 is extended in the nature of a pawl-finger d^{11} , and in the normal position engages with the end of the pawl-lever h^{11} and in contact with one of the teeth h^{13} therein. The relative arrangement of the teeth h^{10} in the rod h and those h^{13} in the lever h^{11} is such that when the finger d^{11} is in contact with one of the teeth h^{13} the lever h^{11} will be slightly back of the corresponding tooth h^{10} on the rod h . A spring h^{14} , attached to the movable frame h^2 , is adapted to move the same laterally along the guide-rods h and h' , except as it is retained by the respective ratchet-teeth h^{10} and h^{13} .

Extending laterally through the standards h^3 is a sliding bar m , having pivotally connected thereto at one end a link m' , which in turn is pivoted to the spring-actuated lever b^9 . This bar m is perforated and has extending through the perforation a pin m^2 , supported on a spring m^3 , secured at one end to said sliding bar and at the other end curved or beveled slightly, as shown at m^4 . This pin normally rests back of the frame h^2 ; but when the sliding bar m is moved by the opening of the cash-drawer the pin is moved past the frame and is forced through the opening in the bar so as to engage the edge of the frame, as shown in Fig. 6, when the sliding bar m is moved backward by the closing of the drawer.

Journalled in suitable bearings in the frame h^2 is a paper-operating roll h^{15} , provided at one end with ratchet-teeth h^{16} , and preferably provided with a series of small spikes or teeth h^{17} in the middle of its length, which teeth or spikes are adapted to engage the paper and withdraw the same from the roll h^7 as the roll h^{15} is rotated in the manner hereinafter specified. From the roll h^{15} the paper may pass through the guide h^9 to a suitable receiving-roll (not shown) in a well-known manner, or it may be made to pass out through a suitable opening in the side of the machine

to form a check or ticket, or otherwise disposed of in such manner as is common in the art.

Adjacent to the ratchet-teeth h^{16} and normally below the bottom of the roll h^{15} is a projecting arm m^5 , the outer end of which is inclined to the line of travel of the frame d , as shown at m^6 . This arm m^5 is preferably formed integral with a vertical plate m^7 , having slotted openings m^8 , through which fastening-screws m^9 pass to attach it to one of the standards h^3 and permit a limited vertical movement. A laterally-projecting finger m^{10} on the plate m^7 projects across and above the movable sliding bar m , which is provided with an elevated cam-shaped part m^{11} , adapted as the bar is moved to engage said finger. A spring m^{12} serves to hold the lever m^5 in its normal position.

Adjacent to the line of travel of the bar m is a stationary inclined cam-piece m^{13} , adapted, as the bar m is moved backwardly, to engage the end of the spring m^4 and withdraw the pin or projection m^2 through the perforation in said bar, so as to release the frame h^2 . A similar stationary cam projection o is adapted to engage the beveled end o' of a pivoted lever o^2 , which carries at its upper end a pawl o^3 , adapted to engage in suitable ratchet-teeth o^4 on the ribbon-carrying spool or roller h^5 .

As thus described the operation is as follows: As a cash-key is depressed the traveling frame d is revolved on the frame-supports e by the inclination of the key-lever engaging the rods d^2 , in the manner before described. This turns the segment d^4 and brings the number on said segment corresponding to the number of the key in line or substantially in line with but below the hammer h^2 . The further movement of the cash-key and its lever, which raises the movable frame d in the frame-pieces e , withdraws the finger d^{11} from the first tooth h^{12} in the pawl-lever h^{11} and allows said pawl-lever to engage the first tooth in the guide-rod h . The further movement of the movable frame d brings the number on the segment corresponding to the key depressed directly opposite the hammer, and the pivoted finger d^9 on the curved arm d^8 contacts with the laterally-projecting portion k' of the arm k and forces said lever backwardly against the spring k^3 , which is thus compressed until the finger d^9 passes the arm k' , when the hammer is released, and, forced by the spring, strikes the paper and causes an impression of the number to be made on the paper in a well-known manner. As the frame d is returned to its normal position by releasing the key the finger d^{11} will descend on top of the tooth which it formerly engaged by reason of the limited movement of the frame h^2 . This will raise the lever h^{11} from out of engagement with the tooth h^{10} , and the frame will be moved by the spring h^{14} until the second tooth h^{13} engages the finger d^{11} , which

will bring the end of the pawl-lever h^{11} in line with but slightly removed from the second tooth h^{10} in the bar h . The operation is again repeated. The traveler on the movable frame has been advanced in a similar manner, as heretofore described, so as to engage the second indicator in the series.

It will be seen that one less tooth is required on the end of the lever h^{11} than in the rod h , as when the finger descends for the next to last time the traveling frame h^2 may be moved at one operation to its proper position. In the present case there being three denominations, three teeth are employed in the bar h and only two in the lever h^{13} . At the second time the finger d^{11} descends it strikes on top of the second tooth h^{13} , and there being no further teeth in said lever to engage the finger d^{11} the frame h^2 will move until the pawl-lever strikes the third tooth in the bar h , which will bring the proper number in the segment in line with the hammer.

As the drawer opens only after the last or units denomination has been operated, the frame h^2 will move along the guide-rods h and h' , so as to print the numbers successively across the strip of paper in their proper numerical order, after which the opening of the drawer through the medium of the link m' draws out the sliding bar m until the spring-actuated pin m^2 engages with the side of the frame. As the drawer is closed the frame carrying the paper and ribbon will be moved back to its normal position, when the end of the spring m^3 , engaging with the stationary cam projection m^{13} , will withdraw the pin m^2 from contact with the frame, which will cause the parts to assume their normal positions. As the traveling frame h^2 is moved laterally by the spring h^{14} the curved or inclined portion m^6 of the arm m^5 is brought back of the teeth h^{16} of the paper-operating roller h^{15} . As the bar m is moved by the opening of the drawer the lever m^5 is raised through the medium of the cam-lever m^{11} , operating against the finger m^{10} , and thus brings said arm m^5 in line with one of the teeth h^{16} on said roller. As the frame is moved downwardly by the closing of the drawer the inclined portion m^6 of said lever, still engaging said tooth, rotates the roll h^{15} one notch and thus advances the paper a corresponding distance. The backward movement of the bar m and the frame h^2 also causes the beveled end o^2 to engage the stationary cam o , and thus, through the medium of the pawl o^3 engaging with the teeth o^4 , advances the ribbon roll or reel h^5 one notch, so as to bring a new portion of the ribbon opposite the hammer.

In Fig. 10 I have shown a slight modification in the form of the keys and their connections. In this case the inclined portion c^3 , which determines the rotary movement of the frame d , is supported on a vertically-moving stem c^4 , and a connection is formed with the cash-key c^2 through the medium of a bell-

crank lever *c*⁵. It is obvious that other modifications, which will readily suggest themselves, may be employed.

It should be noted that the successive operation of the keys for each denomination is necessary in every case a registration is made before the drawer can be opened. If a registration is to be made in the units denomination only, then the first and second depressions shall be of the zero or cipher key. This serves to move the traveling head the proper distance to insure the opening of the drawer after the registration and to imprint a cipher on the recording-strip. If a registration is to be made in the units or tens series, then a zero or cipher will be first recorded in the hundreds series, and so on through any number of denominations which may be employed.

Having thus described my invention, I claim—

1. In a cash-register, a series of cash-keys representing units in any denomination, a series of indicating-wheels representing different denominations and each having numbers thereon corresponding to the units represented on the cash-keys, a movable frame operated by said cash-keys to contact with said indicators and move said indicators to a position corresponding to the number of the key depressed, and means, substantially as described, for successively advancing said traveling frame to cause it to engage with the indicators of different denominations by its successive operation by any key or keys of the same series, substantially as specified.

2. In a cash register and indicator, a single series of cash-keys representing units of any denomination and a series of indicators representing different denominations and each having numbers corresponding to the units of the cash-keys, a movable traveling head or frame adapted to be operated by said keys to move said indicators by the depression of one of said cash-keys, means connected with said traveling frame to successively move the same opposite the indicators of different denominations after any cash-key of the series has been depressed, a numbered part operated by said frame, and a recording device, adapted, by the successive movements of said frame, to be moved in steps across the face of said numbered part and successively contact with said numbered part as each of said keys is operated, substantially as specified.

3. The combination with a series of cash-keys, a rotating movable frame having a numbered segment thereon, a traveling head in said frame, movable parts connected with said keys having inclined surfaces adapted to contact with said frame and rotate the same to different positions of adjustment, and means connected with said frame to successively release and advance said traveling head after each operation of said movable frame, substantially as specified.

4. The combination with a series of cash-

keys representing units in any denomination, and a series of indicators representing different denominations and each having numbers corresponding to the units on said cash-keys, intermediate mechanism adapted to successively operate said indicators by the successive depression of said keys, a normally-locked cash-receptacle, and means connected with said actuating mechanism to unlock said cash-receptacle when the last indicator has been operated, substantially as specified.

5. In combination with a series of cash-keys having connected thereto inclined parts arranged at different angles as described, a rotating movable frame adapted to be rotated to different angles by the operation of said keys, a series of indicators arranged adjacent to said frame, and a traveling head having engaging standards to engage said indicators on opposite sides of its pivotal center, said standards being adapted to be moved by said traveling frame and occupy the same angular position, and means for successively advancing said traveling head at each successive operation of said frame until said standards have successively contacted with each of said indicators, substantially as specified.

6. The combination with a series of cash-keys, a movable rotating frame having a numbered segment, as described, angularly-arranged parts connected with said keys to contact with said frame and move it to different angular positions of adjustment, and a recording device operated by the depression of said keys to record the numbers on said segment corresponding with the key depressed, substantially as specified.

7. The combination with the movable frame having the traveling head thereon, a single series of cash-keys having connected thereto angular parts adapted to successively change the angle of and elevate said frame, engaging parts on said head, and a series of indicators arranged adjacent to said engaging parts, means, substantially as described, for advancing said head after each operation of said frame to cause the engaging parts to be brought successively in line with the different indicators, a normally-locked cash-receptacle, and means connected with said frame for unlocking said receptacle when the traveling head is brought opposite the last indicator of the series, and means connected with said cash-receptacle for returning the parts to their normal positions by the operation of closing said cash-receptacle, substantially as specified.

8. The combination with the movable rotating frame, a series of cash-keys having inclined operating parts connected thereto adapted to first rotate and then elevate said frame, a series of indicators representing different denominations, and a traveling head on said frame having engaging parts adapted to successively operate said indicators by the movement of said frame, means for successively advancing said traveling head after

each operation of said frame to cause the engaging parts of said head to successively contact with the indicators of different denominations, a numbered part connected to said frame and adapted to move therewith, said part having numbers corresponding to the numbers of said keys, and a movable recording device adapted by the operation of said numbered part and record the number brought opposite the same by the movement of said frame, a normally-locked cash-receptacle, and means on said traveling head for unlocking said cash-receptacle by a movement of said frame after said head has moved in line with the last indicator of the series, and means connected with said cash-receptacle for returning all the parts to their normal positions in the operation of closing the same, substantially as specified.

9. The combination with a single series of cash-keys, of a movable rotating frame having a numbered part connected thereto, angularly-arranged parts connected with said keys to change the angular position of said frame, a traveling recording device adapted to be brought successively opposite the numbers on said numbered part, and means for moving said recording device after each movement of said frame so that the numbers on the keys depressed are successively recorded in their proper numerical order on said recording device, substantially as specified.

10. The combination with the movable rotating frame having the numbered segment thereon, cash-keys having connected parts for first rotating and then elevating said frame, a traveling recording device adapted to travel across said segment, and means connected with said frame for successively releasing said recording device to cause it to travel intermittently across said numbered segment after each movement of said frame, substantially as specified.

11. The combination with the cash-keys, the rotating frame, the traveling head on said frame, a series of indicators representing different denominations, engaging parts on said head for said indicators, a numbered segment connected with said frame, means for successively advancing said head after each operation of said frame, and operating parts connected to said cash-keys to first rotate said frame to different positions and then move the same to cause said engaging parts to move said indicators, substantially as specified.

12. The combination with a movable numbered segment, and cash-keys for setting the same, a traveling frame adapted to move laterally across the line of said segment, and means connected with said segment to successively release and permit the movement of said traveling frame after the operation of said cash-keys, and means, substantially as described, for returning said parts to their normal positions, substantially as specified.

13. The combination with the traveling

frame having the recording-strip as described, a sliding bar for returning said frame to its normal position, a pawl-lever having a series of ratchet-teeth in one end and adapted to engage a series of ratchet-teeth at the other end, a movable part for engaging and disengaging said pawl-lever by the operation of a key to cause said frame to successively travel a limited distance corresponding to said teeth, means for returning said frame to its normal position, and engaging devices to operate and advance the recording-strip as said frame is returned to its normal position, substantially as specified.

14. The combination with the movable frame carrying the recording-strip, a sliding bar for returning said frame to its normal position, a toothed roll to engage said strip having ratchet-teeth thereon, an inclined or beveled arm arranged normally below but in line with said teeth, and means on said sliding bar to elevate said arm to cause it to engage said teeth as said frame is returned to its normal position and thus advance said strip, substantially as specified.

15. The combination with a single series of cash-keys, of a number of indicators, each having numbers corresponding to the numbers on said keys, a movable frame having a traveling head, and parallel engaging arms on said head adapted to be brought successively opposite the respective indicators said parallel engaging arms being arranged on opposite sides of the pivotal center of said indicators and adapted to be moved to different angular positions by said movable frame to correspond to the keys depressed, and means for moving said frame by said keys to cause said arms to engage said indicators on opposite sides of the center thereof and thus positively move and stop said indicators in their proper position of adjustment determined by the key depressed, substantially as specified.

16. In a cash-register, an indicating-wheel journaled on a suitable shaft or support and having a cross-bar extending on opposite sides of its center of rotation, a movable rotatable frame having upwardly-projecting arms in line with said cross-bar, a series of cash-keys, and means connected with said keys for first rotating and then elevating said frame to cause said arms to engage with said cross-bar on opposite sides of the center of rotation and thus positively locate the position of said indicator, substantially as specified.

17. The combination with the rotatable movable frame, cash-keys having connected parts for operating the same, a traveling head in said frame adapted to be advanced at each successive operation of said frame, a normally-closed cash-receptacle, a numbered part connected to said frame, and a traveling recording-strip adapted to be successively brought in contact with said numbered part at each operation of said frame, and means connected with said traveling head to unlock said cash-

receptacle after the frame has been operated a definite number of times, and means connected with said cash-receptacle for returning the parts to their normal positions by the operation of closing said receptacle, substantially as specified.

18. The combination with the cash-receptacle, a spring-catch thereon, stationary engaging parts for said spring-catch, a vertically-movable rod having a plunger normally under said catch, a lever connected to said rod, a traveling part having engaging projections for said lever, cash-keys for moving said traveling part, and means for successively advancing the same after each operation whereby the cash-receptacle is opened after a predetermined number of operations of the cash-keys, substantially as specified.

19. A series of levers having beveled or in-

clined ends at different angles as described, 20
a rotating movable frame arranged above the inclined ends of said levers and adapted to be rotated to a position corresponding to the angle of the lever operated when said lever is brought in contact therewith, engaging de- 25
vices on said frame which assume the same angular position as said frame, and an indicator-wheel having a cross-bar arranged above said engaging devices and adapted to be moved thereby as said frame is moved to a 30
position corresponding to the angle of the lever operated, substantially as specified.

In testimony whereof I have hereunto set my hand this 26th day of August, A. D. 1896.

FRANK WOODBRIDGE.

Witnesses:

F. T. MCWHIRTER,

H. G. COLDWELL.