

(No Model.)

3 Sheets—Sheet 1.

G. L. AULT. ADDING MACHINE.

No. 595,592.

Patented Dec. 14, 1897.

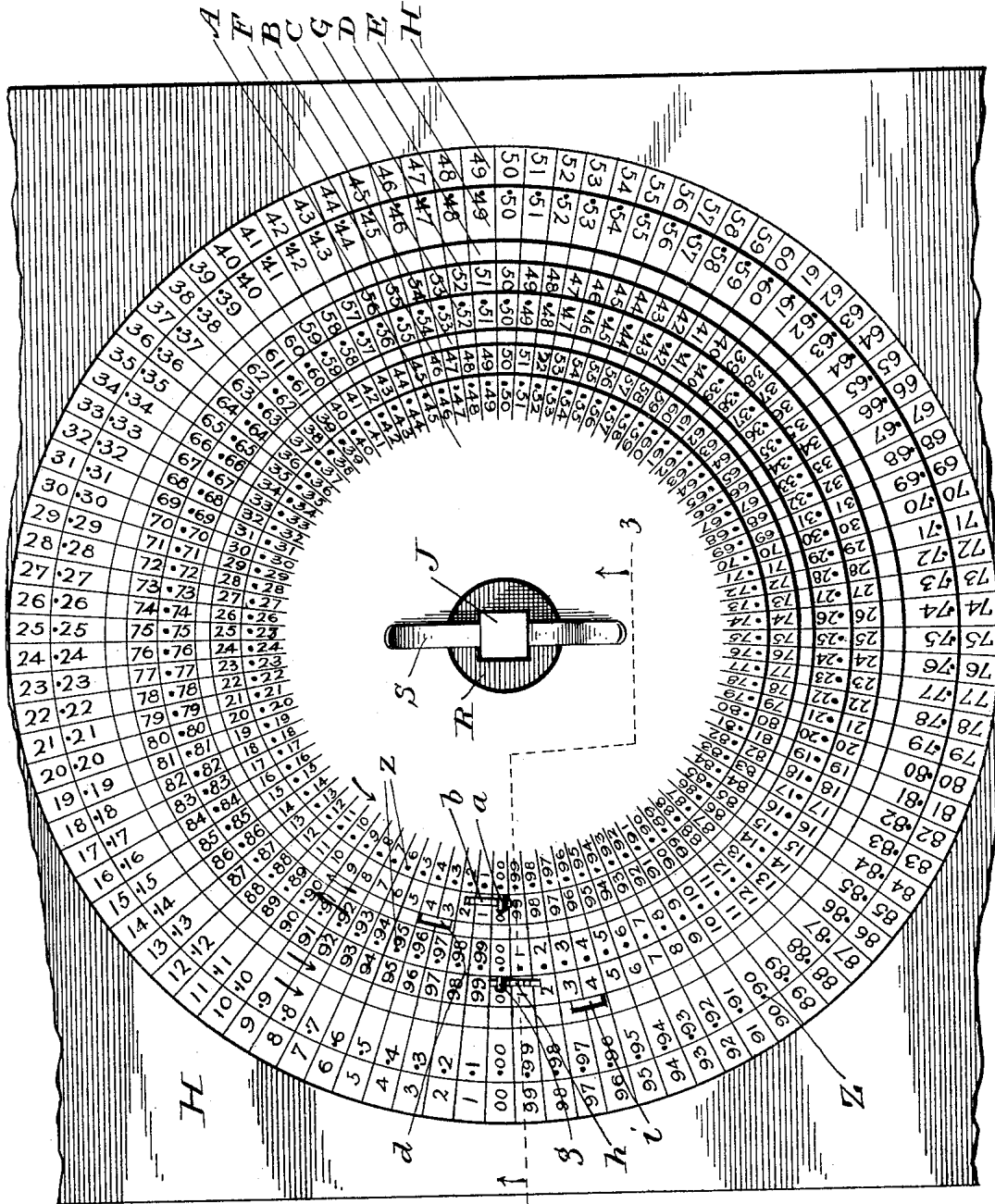

WITNESSES
"J. Frank Culverwell,"
A. M. Poynter

Fig. 1.

INVENTOR
George L. Ault.
By John Henderson
 Attorney

G. L. AULT.
ADDING MACHINE.

No. 595,592.

Patented Dec. 14, 1897.

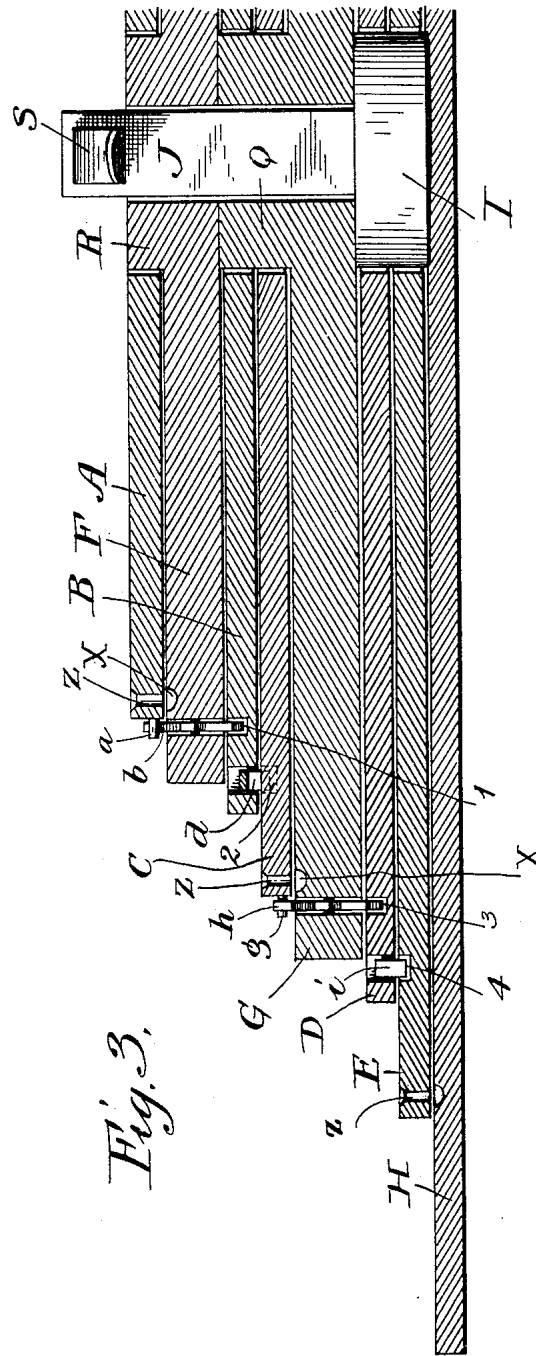
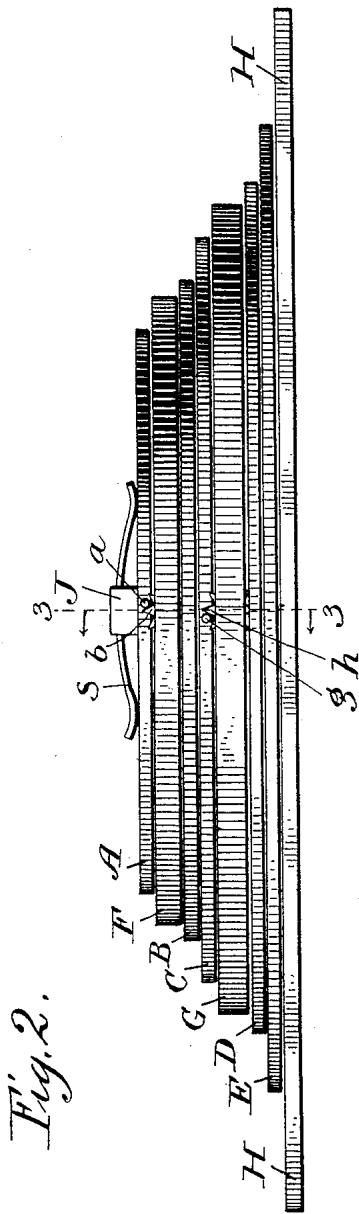

WITNESSES
J. Frank Entwistle,
W. M. Carpenter

INVENTOR
George L. Ault.
John Hedgesburn
 Attorney

(No Model.)

3 Sheets—Sheet 3.

G. L. AULT.
ADDING MACHINE.

No. 595,592.

Patented Dec. 14, 1897.

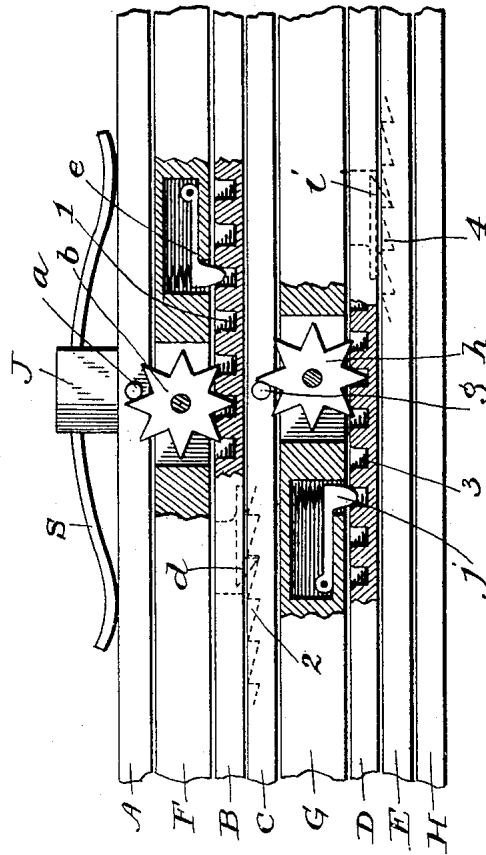
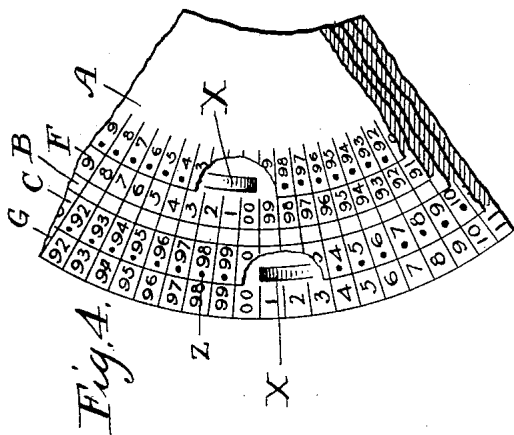
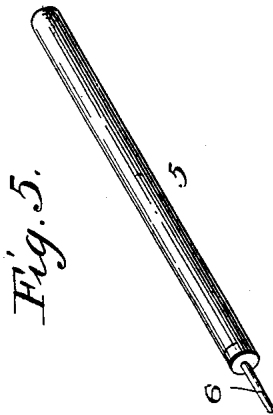

WITNESSES
"J. Frank Culverwell,"
W. M. Dwyer

INVENTOR
George L. Ault
By John Heddlesham
 Attorney

UNITED STATES PATENT OFFICE.

GEORGE LINCOLN AULT, OF BARTLETT, NORTH DAKOTA.

ADDING-MACHINE.

SPECIFICATION forming part of Letters Patent No. 595,592, dated December 14, 1897.

Application filed February 20, 1897. Serial No. 624,453. (No model.)

To all whom it may concern:

Be it known that I, GEORGE LINCOLN AULT, a citizen of the United States, and a resident of Bartlett, in the county of Ramsey and State of North Dakota, have invented certain new and useful Improvements in Adding-Machines; and I do hereby declare the following to be a full, clear, and exact description of the invention, such as will enable others skilled in the art to which it appertains to make and use the same.

This invention has reference to a novel construction in adding-machines; and it consists in the features of construction herein-after fully described and claimed.

In the accompanying drawings, forming a part of this specification, Figure 1 is a top plan of an adding-machine constructed in accordance with this invention. Fig. 2 is a side elevation of the same. Fig. 3 is a vertical section taken on the line 3 3 of Figs. 1 and 2. Figs. 4, 5, and 6 are detail views, which will be understood in connection with the following description.

Referring now to said drawings, H indicates a base-plate for the machine, which is provided with a trunnion I. From the center of this trunnion rises a square post J. The said base H, trunnion I, and post J carry a plurality of disks and plates composing the operative parts of this machine and which consist of three computing-disks A, C, and E, two idler-disks B and D, and two stationary plates F and G. Both the computing and idler disks are rotatable, and the disks D and E, which are lowermost, are provided centrally with openings that fit upon the trunnion I, so that these parts can revolve thereon. The thickness of the disks D and E is such that the upper face of the upper disk D is flush with the upper end of the trunnion I. The upper end of the trunnion I forms an upwardly-facing shoulder, upon which the plate G rests, this plate G being provided with a central aperture to fit the square post J, while said plate G is provided centrally and around the said aperture with an upwardly-extending trunnion Q. The disks B and C are provided centrally with apertures to receive the said trunnion Q, and they rest upon the plate G, their combined thickness being such that the upper face of

the disk B is flush with the upper end of the trunnion Q. Resting upon the upper end of this trunnion Q is a stationary plate F, having a square aperture to receive the post J and provided with an upwardly-extending trunnion R, upon which the disk A turns. The upper end of the post J is provided with a flat spring S, that bears upon the disk A and holds the parts in the above-described position.

The disk A is smaller than the plate F and is provided with a peripheral pin *a* to engage a gear-wheel *b*, that is mounted within an opening near the outer edge of the stationary plate F. This gear-wheel extends above and below the plate F, and the disk B is provided with a plurality of depressions or with an annular rack 1 to receive the teeth of the gear-wheel *b*. In this way it is seen that the rotation of the disk A causes the disk B to rotate in an opposite direction.

To prevent the rotation of the disk B by accident, I employ a spring-pressed detent *e*, that is pivoted to the plate F and enters the depression between the teeth of the rack 1. The disk B is provided with a spring-pressed ratchet *d*, that extends downwardly and engages the toothed rack 2 on the upper face of the disk C, it being noted that the disk B is a little larger than the plate F, although the disk C is considerably larger than the disk B.

It will be seen from the foregoing description that the rotation of the disk B in one direction will cause the similar rotation of the disk C, although the disk C can be rotated in the same direction without moving the disk B, the ratchet *d* passing over the ratchet-teeth 2. The disk C is provided with a peripheral pin *g*, which engages the gear-wheel *h*, that is set within an opening in the plate G and projects above and below the same. The disk D is provided with a toothed rack 3 to intermesh with the gear-wheel *h*, while said plate G is also provided with a spring-pressed detent *j*, that engages the said toothed rack 3 to prevent the accidental rotation of the disk D. The disk E is larger than the disk D and is provided with a ratchet-rack 4 to receive the spring-pressed ratchet *i*, carried by the disk D. It is noted that the ratchets *d* and *i* are set in opposite directions, since the pairs of disks B and C and D and E rotate in oppo-

site directions. Each of the disks A, C, and E is provided near their peripheries with one hundred openings Z, which are equally disposed, while upon the plates F, G, and H, and in alinement with each other are the three recesses X.

I will now proceed to describe the arrangement of the figures upon the different plates and disks. The disks A, C, and E and plates F, G, and H are each provided with figures running from "00" to "99." These figures on the disks A, C, and E are situated opposite the openings Z and to the inside of the same. The pins *a* and *g* of the disks A and C are opposite the figures "00" on these disks. The recesses X upon the plates F, G, and H are opposite "00" upon these plates, it being noted that these recesses begin gradually at about the figure "2" and deepen and end abruptly at "00." The parts are operated by means of the pin *5*, having a small end *6*, that is small enough and of sufficient length to enter the openings Z in the disks and to reach into the recesses X in the plates and base.

The operation of the machine is as follows, namely: The machine is adapted to add the units and tens at one operation, the hundreds and thousands at another operation, and the tens of thousands and hundreds of thousands at another operation. It is understood, of course, that by adding additional disks and plates the capacity of the machine can be increased indefinitely. We will suppose, for instance, that the machine is set with all the "00" marks in alinement. On the disk A and plate F the disk E and plate H the figures increase from left to right, while the figures on the disk C and plate G run in an opposite direction, it being noted that the last-named disk and plate rotate oppositely to the first-mentioned parts. In adding a column of figures the end *6* of the pin *5* is first placed in the opening Z of the disk A opposite the number first to be computed on the plate F. The disk A is then moved from right to left until the point *6* passes into the recess X of the plate F, whereupon the disk A is stopped and the pin removed. In the first movement of the disk A none of the other parts are affected, since the pin *a* on the disk has not passed by the gear-wheel *b*; but suppose that it is desired to add to the sum just computed a second sum which together would equal a hundred or more. It is seen, therefore, that in moving the disk A a second time, as before described, the pin *a*, which stands opposite "00," will turn the gear-wheel *b* the distance between two teeth, which, through the intermediacy of its gearing with the disk B, will cause the disk B to move in an opposite direction the same distance, and this disk B, by reason of its ratchet *d*, will move the disk C the same distance. This operation is continued, it being noted that the gearing between the disk C and disk E will turn the latter the distance between two of the teeth of the gear-wheel *h* at every revolution of

said disk C. It is noted, furthermore, that computing with the disks C or D does not interfere with other disks for computing smaller numbers, owing to the fact that the ratchet connection between the disks B and C and D and E permit the disks C and E to be moved in the proper direction without imparting their movement to the disks A or C, respectively. The computed sum will be found upon the disks A, C, and E in alinement with the "00" mark upon the plates and the base.

Having thus described my invention, what I claim as new, and desire to secure by Letters Patent, is—

1. In an adding-machine, a plurality of stationary plates provided with scales, a plurality of sets of rotatable disks mounted upon said plates and provided with scales, and gearing between said sets of disks to cause each succeeding set of disks to move an interval for each revolution of the preceding disk set.

2. In an adding-machine, a plurality of stationary plates having scales, rotatable computing-disks mounted upon each of said plates and provided with scales, an idler-disk situated between the lower computing-disk and the adjacent stationary plate situated above the same, connections between said idler and computing disks, and a gear-wheel mounted upon said plates and geared to the disks situated below the same and in the path of a pin carried by the disks situated above the same.

3. In an adding-machine, a plurality of stationary plates provided with scales, rotatable computing-disks resting upon each of said plates and provided with scales, an idler-disk situated between the lower computing-disks and the adjacent stationary plates situated above the same, gearing between the said computing-disks and said idler-disks to cause the latter to move once during each revolution of the former, and connections between the adjacent idler and rotatable disks to cause the latter to move in one direction with the former and to allow the latter to be moved in the same direction without moving the former.

4. In an adding-machine, a plurality of stationary plates provided with scales, a plurality of rotatable computing-disks mounted upon the lower stationary plate, a plurality of idler-disks situated between each of said lower computing-disks and the plate situated above the same, a pin upon the upper computing-disks, a gear-wheel carried by each of said plates and situated in the path of said pins, racks upon said idler-disk intermeshing with said gear-wheel, a spring-pressed detent upon each of said upper plates engaging with said toothed racks upon the idler-disks, and spring-pressed ratchets carried by each of said idler-disks and engaging ratchet-racks in the upper face of the computing-disks.

5. In an adding-machine, a stationary plate provided with a scale, a gear-wheel mounted

in said plate and projecting above and below the same, a computing-disk smaller than said plate and provided with a pin situated to engage said gear-wheel, a scale upon said disk, 5 another plate situated below said first-mentioned plate and provided with a scale, a computing-disk resting upon said last-mentioned disk and provided with a scale, a spring-pressed detent mounted upon said first-mentioned plate to engage a rack upon an idler-disk situated between the lower computing-disk and said first-mentioned plate, and a spring-pressed ratchet carried by said idler-disk and engaging a ratchet-rack in the lower 15 computing-disk.

6. In an adding-machine, a stationary plate having a circular scale, a recess near the outer edge of said plate, said recess having an inclined bottom beginning at the surface of the 20 plate and ending at an abrupt wall, the abrupt wall being opposite one number in a scale upon said plate, a rotatable disk mounted upon said plate to rotate concentrically with the scale thereon and provided itself 25 with a circular concentric scale, and a circular concentric line of openings in said rotatable disk, one opening being opposite each

number of the scale therein, and said openings being situated to pass over the said recess of the plate. 30

7. In an adding-machine, a base-plate provided with a circular trunnion and an uprising post, a plurality of plates having central apertures to receive said post and to which they are secured against rotation, the lower 35 plate resting upon the trunnion of said base-plate, uprising trunnions concentric with said plates, the uppermost plates resting upon the upper ends of the trunnion of the plates below the same, sets of disks having concentric 40 apertures to receive said trunnions of the base-plate and plates, each set being situated between two of said plates, a spring connected with the upper end of said post and bearing against the uppermost disk, scales upon said 45 plates and disks, and gearing for causing the relative rotation of said disks.

In testimony whereof I have signed this specification in the presence of two subscribing witnesses.

GEORGE LINCOLN AULT.

Witnesses:

ROBERT MILLER,
F. E. SMITH.