

(No Model.)

4 Sheets—Sheet 1.

W. P. PARSONS. CASH REGISTER.

No. 601,164.

Patented Mar. 22, 1898.

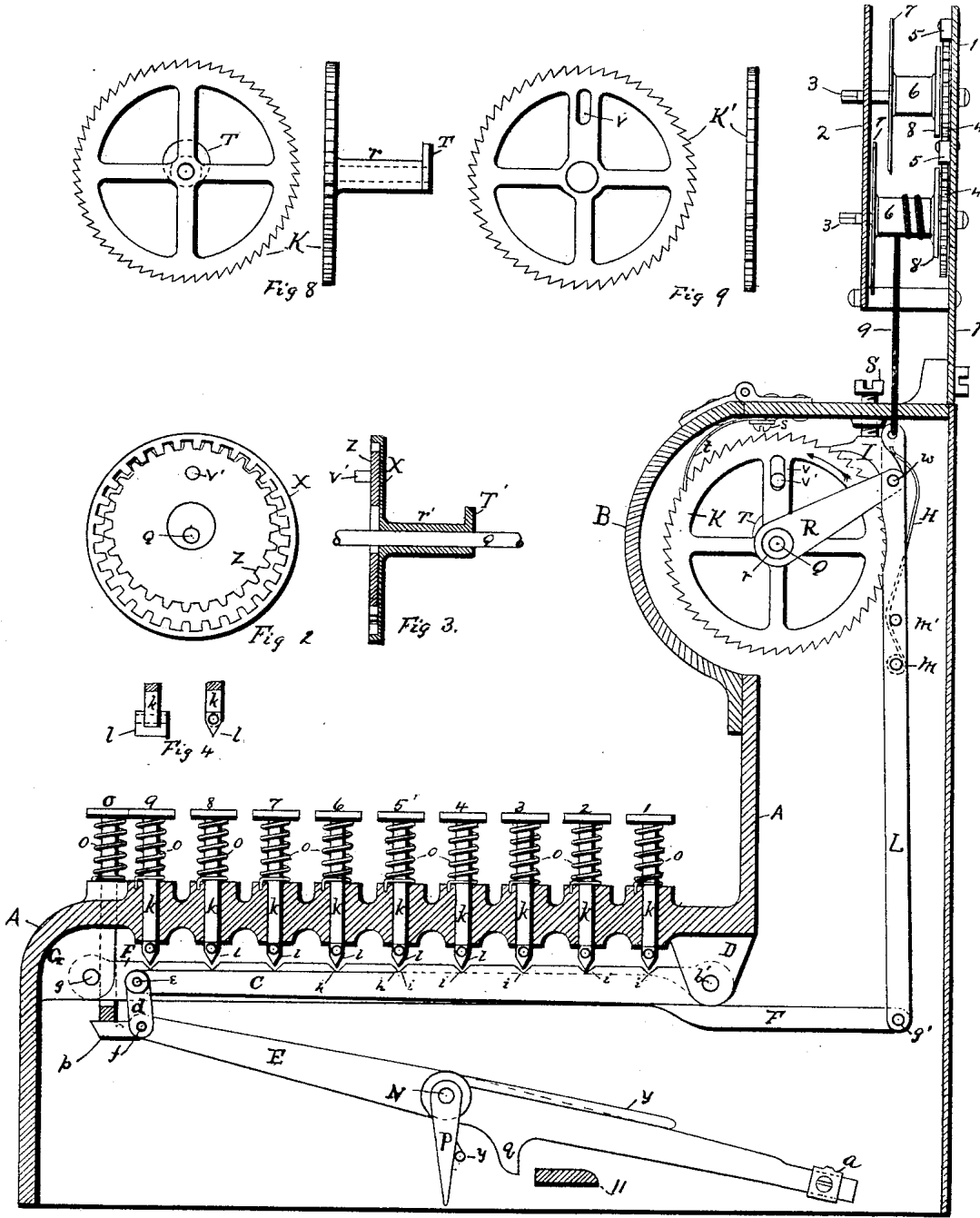

Fig 1

WITNESSES:

Isaac A. Allen
Isabel Parker

Willard Pope Parsons INVENTOR.

BY
J. Russell Parsons
ATTORNEY.

W. P. PARSONS.
CASH REGISTER.

No. 601,164.

Patented Mar. 22, 1898.

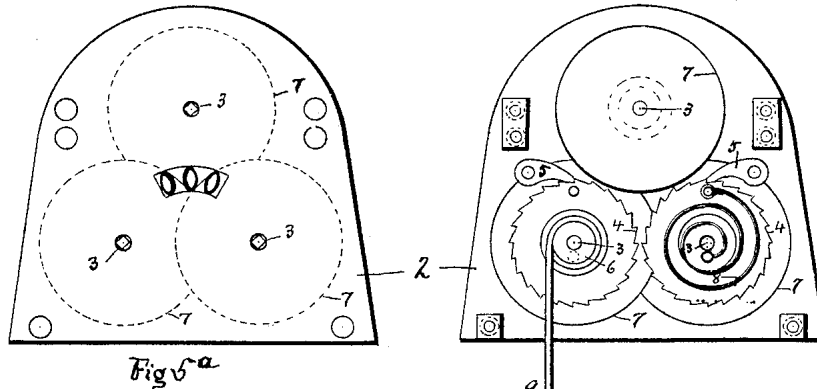

Fig. 4a

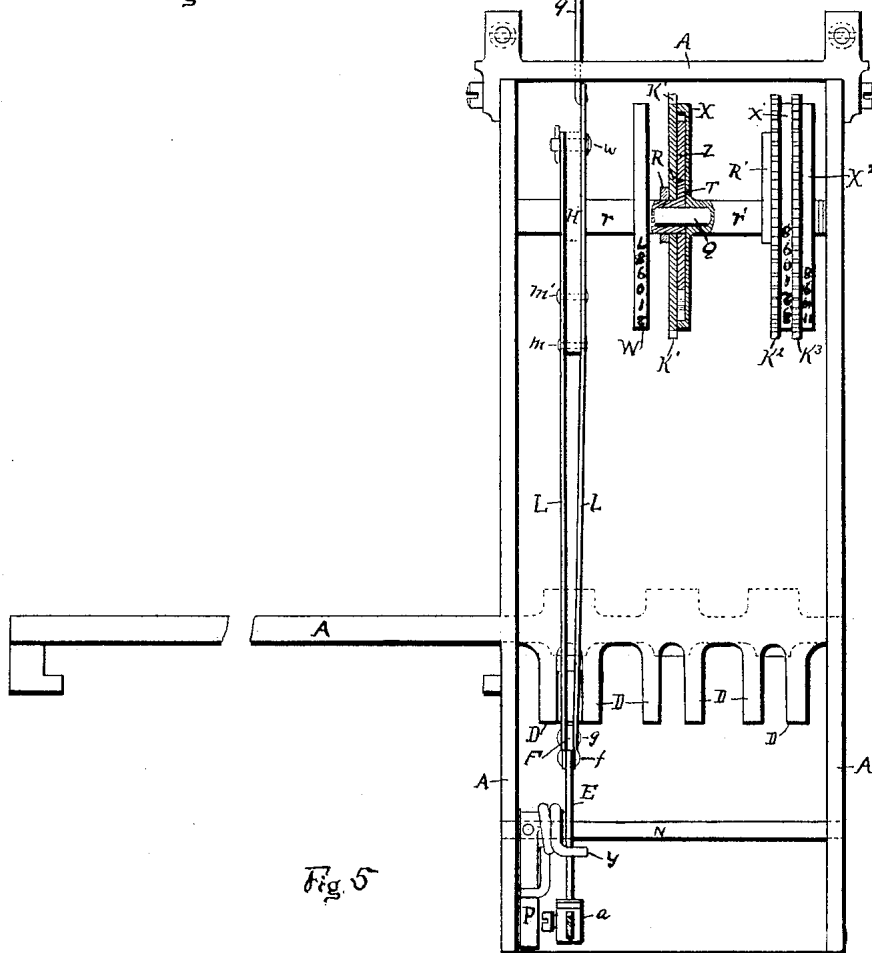

Fig. 5

WITNESSES:

Isaac A. Allen

Isabel Banker

Wilson Pope Parsons INVENTOR,

BY

J. Russell Parsons

ATTORNEY.

(No Model.)

4 Sheets—Sheet 3.

W. P. PARSONS,
CASH REGISTER.

No. 601,164.

Patented Mar. 22, 1898.

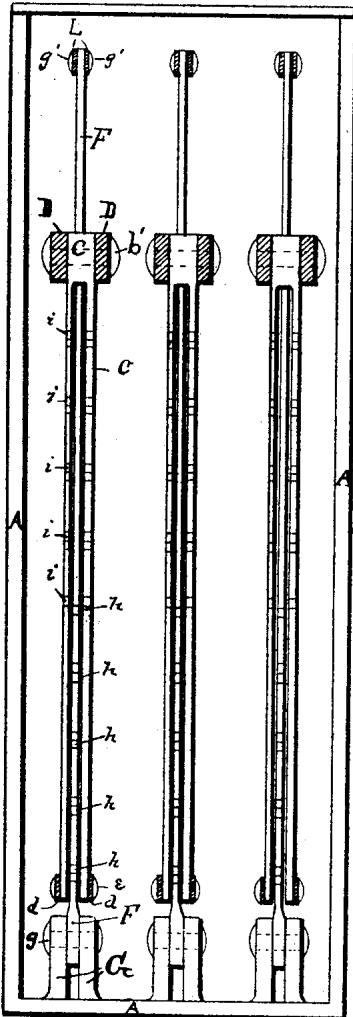

Fig 6

WITNESSES:

Isaac A. Allen
Isabel Banker

William Pope Parsons INVENTOR.

BY
J. Russell Parsons
ATTORNEY.

(No Model.)

4 Sheets—Sheet 4.

W. P. PARSONS.
CASH REGISTER.

No. 601,164.

Patented Mar. 22, 1898.

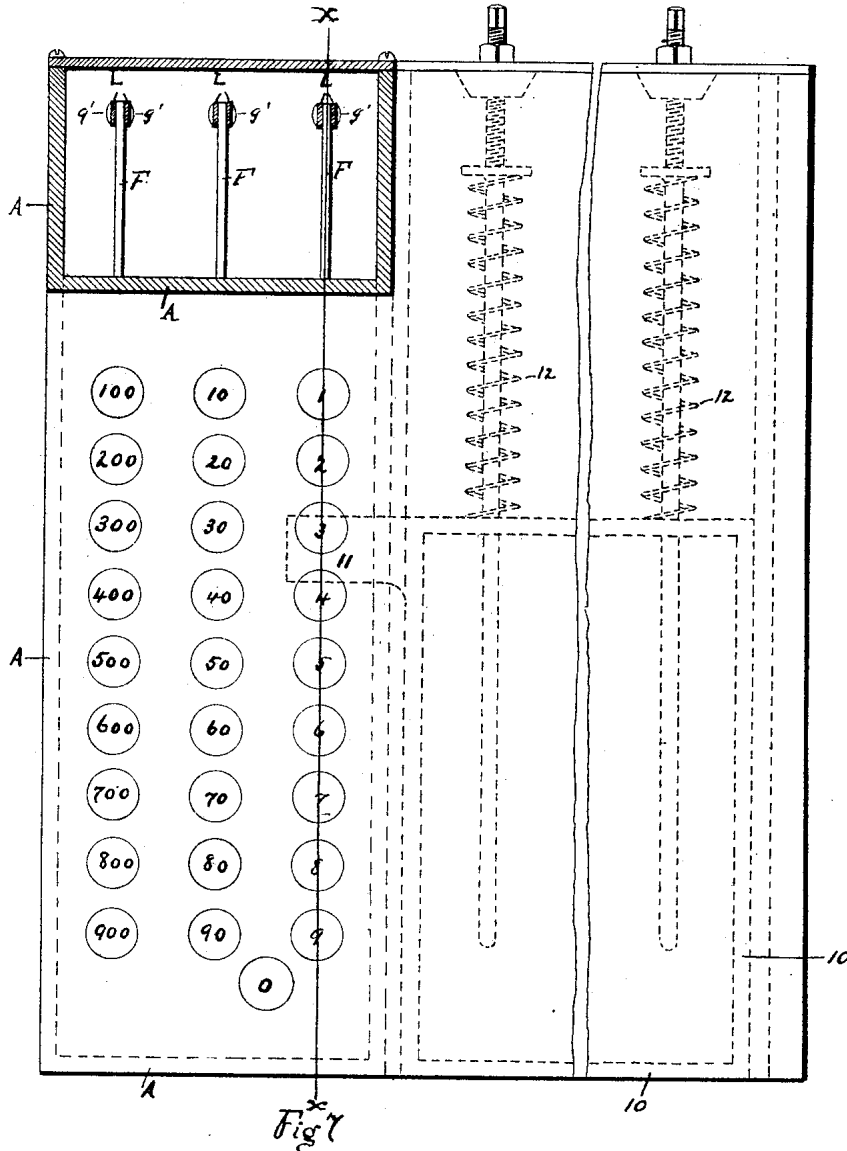

WITNESSES:
Isaac A. Allen
Isabel Banker

Willard Pope Parsons INVENTOR.
BY
J. Russell Parsons ATTORNEY.

UNITED STATES PATENT OFFICE.

WILLARD POPE PARSONS, OF HOOSICK FALLS, NEW YORK.

CASH-REGISTER.

SPECIFICATION forming part of Letters Patent No. 601,164, dated March 22, 1898.

Application filed February 19, 1896. Serial No. 579,838. (No model.)

To all whom it may concern:

Be it known that I, WILLARD POPE PARSONS, of the village of Hoosick Falls, in the county of Rensselaer and State of New York, have made certain new and useful Improvements in Cash-Registers; and I do declare the following to be a full, clear, and accurate description thereof, reference being had to the accompanying drawings, making a part of this specification, in which—

Figure 1 is a view in elevation, showing the casings and a projection from the drawer in section on line *xx*, and Fig. 7 shows the levers, press-buttons, register, and indicator in position. Figs. 2 and 3 are views in elevation and section of the carrying mechanism. Fig. 4 is a view showing side and front elevation of the lower end of the press-button stems. Fig. 5 is a view showing a rear elevation of the case and mechanism for one set of levers with back plates and drawer removed. Fig. 5^a is a view in elevation of the front plate of the casing which incloses the indicating-wheels and shows the opening from which the figures are read, showing the machine in its normal position. Therefore nothing but zeros are shown. It also shows the dials in dotted lines. Fig. 6 is a plan view of the levers within the casing. Fig. 7 is a plan view of the case with registering-box in section and the drawer-springs and drawer in position, shown by dotted lines. Fig. 8 shows an end and side elevation of the ratchet-wheel for the units row of buttons. Fig. 9 shows an end and side elevation of the ratchet-wheel for the rows of buttons of denominations higher than units.

Similar letters and numerals of reference in the several figures represent the same parts.

To enable others skilled in the art to make and use my invention, I will proceed to describe the same with reference to the drawings.

The construction shown and described is for a cash-register having a capacity to indicate any number from "1" to "999" and to register any number from "1" to "59,999," which under my system I term a "three-lever" machine. This capacity can be increased indefinitely by the employment of more levers, press-buttons, and attachments under the same system. The device is so constructed that a large part of the machine

can be placed under the counter or other support, the indicator only being exposed. This economizes counter-room and avoids the necessity of expensive ornamentation. The registering and indicating devices are so connected by operating mechanism that the same number is indicated when the buttons are pressed as is added to the number on the registering-wheel, which is absolutely exact and prevents one source of fraud.

A is the casing (shown in Fig. 1 in cross-section taken through the center line of one row of press-buttons) and is of sufficient width to receive all the rows of press-buttons and connecting mechanism, and, as shown in rear elevation in Fig. 5, the horizontal portion of this casing, which supports and guides the press-button stem *k*, is made heavier than the other parts and is provided with bosses on its upper and under surfaces for the passage of each press-button stem in order to afford a long bearing for each stem. The press-button stems are made with polygonal cross-section (shown in Fig. 4 as square) to prevent their turning, and of course the casing is provided with corresponding holes for the reception of the press-button stems.

The portion of the casing at the left, Fig. 1, is shown curved at the top and extends downward, which forms one side or face of the counter into which the machine is fixed. The other end extends vertically upward above the level of the buttons a sufficient distance to receive the lower end of a hinged curvilinear flap or door B, which covers the registering mechanism. This flap or door is locked to the casing at all times except when it is desired to open it to read the register to see how much cash has been received.

One row of press-buttons *k*, as shown in Fig. 1, are numbered 9 8 7 6 5 4 3 2 1. The rest of the buttons are numbered as shown in Fig. 7. These buttons are each furnished with a stem *k*, smaller than the button ends, and each has a spring *o* coiled around it. The lower end of the spring is fast in the casing and the upper end abuts against the under side of the button, so as to retain the stem on its uppermost position. When the button is pressed downwardly, and with it the stem *k*, the spring is overcome. The pressure being removed the spring will return the

button and its stem to its former position. The lower end of each press-button stem is provided with a wedge-shaped piece *l*, pinned to it, as shown at Fig. 4, the use of which will be more fully hereinafter described.

To the under side of the casing are fastened three pairs of brackets D, one pair for each row of press-buttons, and arranged a sufficient distance apart from the center line to receive the end of the lever C, (shown partly in full and partly in dotted lines,) each lever being pivoted in its pair of brackets by means of the bolt or rivet *b'*. The lever C is bifurcated from a point near its hinged end throughout its length, and at the outer end of each of the arms composing the lever is pivoted a link *d*, by means of the bolt or rivet *e*. This link is composed of two parts, one on each arm, projecting downwardly and receiving the end of a lever E, pivoted between the parts of the link by means of the bolt *f*. (Shown in Figs. 1 and 5.) The purpose of this lever E will be hereinafter explained. A lever F is pivoted in a bracket G, secured to the under side of the casing at its upper left-hand corner, as shown in Figs. 1 and 6, by means of the bolt or rivet *g* and extends toward the right between the two arms of the lever C.

The levers C and F are notched on their upper edges throughout a portion of their lengths, as shown at *i* and *h*, Fig. 1. Their notches receive the wedge-shaped ends of the press-button stems before referred to. The lever F is notched to receive the press-button stems *k* belonging to buttons 5, 6, 7, 8, and 9. The lever C is notched to receive the press-button stems *k* belonging to buttons 1, 2, 3, 4, and 5. The notches made in lever C are made in both of its arms opposite each other, and when notches occur in either lever C or F a smooth surface occurs in the other. This smooth surface is the top edge of the lever and on a line with the bottom of the notch. The wedge-shaped end of the press-button stems being made long enough comes in contact at its edge with the bottom of the notches in arms of lever C and the plain surface of lever F, and vice versa, thus acting on both levers simultaneously. This construction, as shown in the drawings, requires the levers to be dropped down as to the height of their upper edges from about the middle to the end, the lever C being dropped down at the free ends of its bars, the lever F being dropped down at the end opposite its pivot. I have shown the division of the notched and plain portions of the levers at a point where the stem (marked 5) engages the levers.

The construction of the levers C and F, with their attachments, is the same in the three rows or divisions, or for any additional number of rows or divisions. The same is true of lever E, except the one operated by the unit row shown in the drawings. The other E levers and attachments are alike and

differ from the one shown in Fig. 1 by leaving off from the lever the projection *p* at the left-hand end and the projection *q*. However, these may be retained, as they will do no harm, on the other levers, it being only a saving of material to leave them off.

The press-buttons, with their attachments, are all the same in the different rows, as to mechanism, being marked with their proper numbers. I have shown in the drawings the three rows which I call the "unit" row, the "dime" row, and the "dollar" row, with the releasing-lever E preferably connected with the units row.

The lever F is prolonged toward the rear of the machine, and at its end is pivoted the vertical connecting-rod L. This connecting-rod is made in two parts, of flat metal, pivoted at their lower ends astride the lever F by the bolt *g'*, and at their upper ends are spread far enough apart to receive the flat spring H. The lower end of this spring is bent around the bolt *m* and passes over the bolt *m'* on the opposite side from where it leaves the bolt *m*, its upper end pressing against the pawl I, the pawl being pivoted between the parts of the arm L on the bolt *w*. This pawl engages with the ratchet-teeth in the periphery of the ratchet-wheel K and imparts motion thereto at the proper time. The lever E, before alluded to, is pivoted at or near its middle on the shaft N, which shaft extends from one end of the casing to the other, is arranged to turn in its bearing, and receives the other similar levers of the series in the same manner. Securely fastened to this shaft is a projecting lever P, which extends downwardly, and is formed with a hub around which is coiled a spring *y*, the coil in the spring being made at the right place in its length to allow its lower end, which is bent at right angles, to extend across the rear edge of the arm P and its upper end to extend some distance rearwardly along the top edge of the lever E. The lever P, being fast to the shaft N and the shaft N being free to turn in its bearings, the shaft N will turn when the projection 11 strikes the lever P and will assume a position in rear of the projection 11 when the drawer is thrown out. At the rear end of lever E is placed a sliding piece *a*, the lever E being fitted to receive it. This piece is fitted with a set-screw to hold it in any required position.

The ratchet-wheel K must be made with a number of teeth divisible by ten without a remainder, the reason being obvious, as the machine is adapted to the decimal system. The wheel used for the unit line or row is a plain ratchet-wheel, turning freely on the shaft Q. An arm R turns at its lower end on the hub *r* of the ratchet-wheel, its upper end being pivoted to the top of the connecting-rod L and acts as a guide to pawl I, so that when the rod L is pushed upwardly the pawl I will be in engagement with one of the ratchet-teeth, and thus turn the ratchet-wheel K in

the direction shown by the arrow a certain distance, which distance is variable and determined by the particular button which is pressed. To the under side of the casing is secured by the screw *s* the spring *t*, which engages with another tooth of the ratchet-wheel to prevent the wheel from taking any backward movement, and holds it in the position predetermined by the movement of the pawl

I. Through the upper portion of the casing I pass a set-screw *S*, which serves to stop the movement of the pawl at the right time. This is all that is required to register the units to "9," inclusive. In order to register beyond "9," I connect the units ratchet-wheel with the tens ratchet-wheel. To register hundreds, I connect in the same manner the tens with the hundreds, and so on, this connection being now described.

On the hub *r* of ratchet-wheel *K* is placed the eccentric *T*, which turns in an opening in the center of an external gear-wheel *Z*, as shown in Figs. 2 and 3, which gear-wheel *Z* meshes with another and larger internal gear-wheel *X*. The ratio of the sizes of these gears must be such as that the smaller or external gear shall have a number of teeth less than the larger or internal gear, as is represented by the number of teeth in ratchet-wheel *K* divided by ten. Thus if the ratchet-wheel has sixty teeth, as represented in the drawings, the external gear—*i. e.*, the one with cogs external to its periphery—should have fifty-four teeth and the internal gear sixty teeth, or in the same ratio.

Fig. 9 represents the ratchet-wheel *K'*, which registers the tens. It is placed on the hub of wheel *K*, so it can turn thereon between the ratchet-wheel *K* and the eccentric *T* and adjacent to the eccentric. One of the arms of *K'* (or, if a solid wheel, its disk) is provided with an oblong hole *v*, which receives a pin *v'*, fast to the disk of the gear-wheel, having teeth externally or spur-pinion *Z*. This ratchet-wheel *K'* must have a less number of teeth than ratchet-wheel *K* by so many as the number of teeth in *K* divided by ten. As shown in the drawings, it has fifty-four teeth, the ratchet *K* having sixty teeth.

The internally-cut gear *X* is furnished with a hub *r'* and eccentric *T'*, Figs. 2, 3, and 5, the same as the one hereinbefore described, located on the hub of ratchet-wheel *K*, which registers the hundreds. All the other mechanism used to operate the tens, hundreds, &c., is the same as described in the units division. The same construction is carried farther if it is required to register thousands, and so on.

As before stated, I have shown a mechanism to register and indicate units, tens, and hundreds, and, as shown, will indicate up to "999." I add to this combination another set of wheels, which will increase the capacity of the register in the way of addition on the scale shown up to "59,999." This set of wheels is placed at the end of the hundreds or, in the event of the addition of one or more

series or divisions, at the end of the last or highest denomination series. Wheel *K*³ is made to turn by hand to set it, say, at zero or any other figure. This wheel is not necessarily a ratchet-wheel, as any wheel which can be clamped and loosened is all that is required. The series hereinbefore described are set at zero by operating the buttons. The registering-wheel of this addition is set at zero or any other number by turning the wheel *K*³ by hand, and the subsequent additions are registered automatically, the only addition to the wheel *K*³, which is mounted on the hub of the last gear-wheel, being the two gear-wheels constructed and arranged in the same manner as hereinbefore described.

The proper figures for registering may be placed on the face of the gear-wheels *X* *X'* *X*² and a wheel *W*, which registers the units.

The ratchet-wheel *K* in Fig. 5 is hidden behind the spring *H*; but said ratchet-wheel is connected by the hub *r* and eccentric *T* with the wheel *K'* for the purpose of transferring the tens, and, similarly, the wheel *K'* is connected with the wheel *K*² and the wheel *K*² with the wheel *K*³.

In this construction when an indicator to show the purchaser or others the amount of the purchase is required I construct the indicating part of the machine as follows: On top of the casing *A* is fastened in any suitable manner a plate 1, extending upwardly, as shown in Figs. 1 and 5. This plate supports an opposite plate parallel to it by means of bolts shouldered at both ends, after the manner of clock-pillars, at a sufficient distance to receive three shafts 3 3 3, Figs. 1, 5, and 5^a, and to each of these shafts is rigidly fastened a ratchet-wheel 4, held by a pawl 5, riveted to plate 1. Each shaft carries a drum 6, which turns freely thereon and provided with a disk or indicating-wheel 7, rigidly fastened to the drum at the end opposite the ratchets. Upon these disks or indicating-wheels are numbers "0" to "9," both inclusive, placed in a circle near their peripheries. Each drum 6 is connected through the spring 8 with the ratchets. The end of each shaft projects through the plate or casing 2 and is made square at the end for the purpose of regulating the tension of the spring by a wrench. A cord 9 or other flexible connection is fastened at one end to the end of the connecting-rod *L* and its other end coiled around and fastened to the drum 6, so that when the rod *L* is forced downward motion is imparted to the drum 6, overcoming the pressure of the spring, and when the force is removed the spring acts to turn the drum 6 and rewind the cord, but is not strong enough to remove the register ratchet-wheel. The spring is also so adjusted as to balance the weight of the lever *F* and its connecting parts. Each disk has its lever *F*, connecting-rod *L*, flexible cord 9, drum 6, spring 8, and ratchet 4 all alike.

Should the machine be required for registering only, the indicating apparatus can be

dispensed with by simply substituting a spring connection between the rod L and the casing. The money-drawer is preferably located below the counter and supported on a projection of the casing A, as shown in Figs. 5 and 7. The drawer 10, as shown in dotted lines in Fig. 7, carries a projection 11. (Shown in plan view in Fig. 7 and in cross-section in Fig. 1.) It is supported in guides in any well-known way, and at its rear are two rods, on each of which are coiled springs which press against the back of the drawer and tend to open it when it is unlocked, which springs have to be overcome when the drawer is closed or pushed in by the operator. The drawer is locked when closed by means of its projection 11 coming in contact with projection *q* on lever E. It is plain that the different parts must be so adjusted and timed with each other as to operate at the right time and for the right distance to accomplish accurate registry and indication. For this reason ample adjustments are provided; but when the machine is once adjusted there is very little, if any, liability to get out of adjustment.

The operation of the machine is as follows: The machine is set up with the plane of the top of the buttons flush with the upper surface of the counter, the dials or disks, with their numbers, exposed both to the purchaser and the seller. When the machine is first ready for use, the drawer is shut, and held shut by the projections *q* and 11, the dials and registering-wheels all being set at zero. Assuming one of the units-buttons is pressed to register a purchase of any number from "1" to "9," inclusive, the levers F and C are depressed. The lever C tilting the lever E on its fulcrum N through their connection *d*, the piece *a* rises with the opposite end of the lever E until it comes in contact with the descending lever F, and thereby limits the motion. It is plain that the position in space of the levers F and E when brought into contact will depend on the button pressed, owing to the location of the units-buttons with reference to the levers. When a button is pressed, the lever F carries with it downwardly the connecting-rod L and pawl I, leaving the pawl I in engagement with the tooth on the ratchet-wheel corresponding to the button pressed. The lever F through connecting-rod L and cord 9 rotates the indicator-dial until the proper number appears in place of zero. When the lever E is tilted, as above stated, it frees the drawer, and the springs, acting on the back of the drawer, throw it out, and projection 11 takes a position in front of lever P. When the deposit is made, the drawer is returned by the operator. In this operation the projection 11 strikes against the lever P, turning the shaft N, to which it is fastened. The lever P carries with it the spring *y*, the long end of which strikes against levers F and C and forces them into their original position, carrying the connecting-rod L upwardly, thereby causing the pawl I, guided by arm R, to rotate the ratchet-wheel

the distance due to the particular button pressed. In order that the momentum shall not drive the ratchet-wheel too far, I place the set-screw S in the casing and so adjust it that the pawl I will strike the set-screw S at the proper time. The figures on the indicating-dials are changed to zero as the upward movement of the rod L slackens the cord and the spring 8 rewinds the cord on the drum 6 and rotates the dial to its normal or zero position. The units-registering wheel W is turned through the same number of degrees as the units ratchet-wheel. Having taken sixty teeth on the units ratchet-wheel as the proper basis for the illustration, the numbers on the corresponding registering-wheel must be repeated six times—that is, there must be six sets of numbers from "0" to "9," both inclusive, on its circumference. This is the case also with the numbering on the circumference of the other registering-wheels, excepting the last wheel, carrying the highest order of numbers, which I term the "extra adding-wheel" and is not furnished with a set of press-buttons, which has been before described, and this is numbered from "0" to "59," both inclusive. The eccentric T on the hub of the units ratchet and registering wheels moves the spur-wheel Z, and through the intervention of the pin *v'* on wheel Z, passing through the slot *v* on wheel K', and by reason of the difference in rotation of wheels X and Z, due to the differing number of teeth, the wheel K' is rotated at a speed which is one-tenth of the speed of the ratchet-wheel K. Consequently the movement of the registering-wheel in tens division will be one-tenth the movement of the registering-wheel in the units division. The eccentric T' will operate the registering-wheel in the hundreds division, and so on, and each registering-wheel will be governed in the extent of the movement by the requirement of each button pressed. The action of the press-buttons on the levers and other mechanism which are in the tens and higher divisions is the same as on the units division, with the exceptions, first, the levers P of the higher divisions have no connection with the extension 11 of the drawer, but have their springs *y* operated by similar figures to lever P of the units division, but which are fast to the same shaft as P, and the shaft is turned by the contact of lever P with projection 11; second, the ratchet-wheel is connected to the registering device by means of the slot *v* in the ratchet-wheel and pin *v'* in the spur-wheel Z, as it has no hub, but its center is supported on the hub of the next lower system. As the ratchet-wheel rotates it carries spur-pinion Z with it, rotating it on its eccentric and conveying a rotary motion to the internal gear and registering-wheel X and the eccentric for the hundreds division, and so on. This system not only registers the units for a units purchase, but carries forward its result to the tens and hundreds and other higher denominations that are involved in the machine, so that when

the last figures are read at any time from each of the wheels, commencing with the highest grade, the total amount of the receipts will be had.

5 The method of indication, and by "indication" I mean the exhibition of figures to show the purchaser the amount of his purchase, it will be seen from the foregoing description, consists of a set of figures from "0" to "9,"
 10 placed in a circle on the face of a disk. There are to be as many of these disks as there are decimal denominations. I have shown and described in this application one for units, one for tens, and one for hundreds,
 15 with their actuating mechanism connected therewith. The plate 2 has an opening 13, through which these figures are exposed when the machine is in its normal condition—that is, when the money-drawer is shut the three
 20 zeros will appear. When the purchase is made, if the purchase exceeds number "9"—that is, if it is large enough to represent tens and not large enough to represent hundreds—the button representing the tens figure of the
 25 number in the tens row is pushed first, (the representative of the highest denomination being always pushed first,) the units last, as the units row of buttons, with its mechanism, is the only one, as herein arranged and shown,
 30 which unlocks the drawer, as the drawer is located on one side and in close proximity to the units line. The machine may be so constructed, however, that either row of buttons may trip the drawer; but it is the natural
 35 way to read and write amounts to commence with the unit representing the highest denomination. For instance, if it is desired to write "125" we always write the "1" first, "2" second, and "5" last. It is plain that
 40 in some combinations of figures it is necessary to have a separate button which will act on the tripping-lever without indicating or registering. For instance, if it is required to register "111" you would push the button
 45 marked "1" in the hundreds row first, the button marked "1" on tens row second, and the button marked "1" on the units row last. This last will trip the drawer. But if the required number was "110" you would press
 50 the button marked "1" on the hundreds row first, next the one in the tens row, leaving the zero in the indicator unmoved. Then you have the "110" displayed, but have not tripped the lever which releases the drawer.
 55 In order that it may be thrown open by the springs or in case it is required to open the drawer when no purchase has been made, some device must be arranged for this purpose. I provide, as shown in Figs. 1 and 7,
 60 another button marked O, which is fitted with a stem and spring located at some convenient place where it will act on the units-lever E. The stem is made with a blunt end and strikes on the projection of the lever E
 65 and tilts it, thus freeing the drawer. The lever F not being acted upon nothing will be indicated or registered.

This machine will indicate from one cent upward, as above shown, and register perfectly, making complete additions as small
 70 as one and to any number in a machine as herein described, with three sets of buttons and their mechanisms to "59999," at a comparatively small cost and very compact.

The gear-wheels X, X', and X'' instead of
 75 being numbered with the registering-digits may have attached to them registering-disks like W to receive numerals; but I prefer placing the numbers directly on the wheels for cheapness and simplicity. Other mechanisms
 80 may be used between the buttons and the gear-wheels. The best form, however, I deem the one shown. The predetermined difference of the number of teeth in the gear or registering wheels allows the correct
 85 consecutive addition of the sum, so that the amount can be read in the decimal numbers from the adding and registering wheels at any time between zero and the highest number, the limit being the capacity for which the
 90 machine is made.

In this specification I have described a machine which has a ratchet-wheel K having
 95 sixty teeth; but this number of teeth is arbitrary. It is necessary, however, that this ratchet-wheel should have a number of teeth divisible by ten without a remainder, as this system of enumeration consists of ten
 100 primary digits—namely, "0," "1," "2," "3," "4," "5," "6," "7," "8," and "9"—and each tooth must represent one digit. To correspond with this construction, I must have these digits consecutively repeated on the first registering-wheel W six times. In
 105 this specification I have assumed the registering-wheels to be of equal size and all numbered alike, as I deem this the cheapest and simplest construction. The first ratchet-wheel K has sixty teeth. The ratchet-wheels K' K² K³ and whatever others may be
 110 added each have fifty-four teeth only. The first ratchet-wheel K is rigidly connected to the first registering-wheel W, and consequently the two must move together. Not so with the remaining wheels K' K² K³, be-
 115 cause there is interposed the eccentric and gear Z between the ratchets and their registering gear-wheels X X', &c. For example, suppose it is required to register a purchase
 120 of two cents. It will be registered in the following manner: Press the button marked "2" in the units division, which will pull down the pawl I on the ratchet-wheel K two teeth, and through the mechanism already described the
 125 drawer will then be thrown open. When the drawer is closed, the ratchet-wheel will be turned two teeth in the direction of the arrow, and the registering-wheel W will be turned a corresponding distance and expose the figure "2." The eccentric, which is fast
 130 on the hub of the ratchet-wheel, will be moved, and in turn will move the gear Z, directed and controlled by the ratchet K', stationary at this time, by means of slot *v* and pin *v*,

and this motion will move the registering gear-wheel X the amount registered on wheel W, which will be two-tenths of one space between the digits. Succeeding wheels will be moved their corresponding amounts. The registering gear-wheel in the tens division will be moved two-tenths of two-tenths, or two one-hundredths, and so on decimally. This completes the register of the two-cent purchase. Suppose the next purchase to be twenty-five cents. The button marked "2" in the tens division is pressed and the button marked "5" in units division. Both buttons set their respective pawls on ratchet-teeth and, pressing the units-button last, open the drawer, and the mechanism is operated as before. The twenty-five cents in addition to the two cents will be shown on the registering-wheels as twenty-seven cents, so that the last purchase includes in its registration all former purchases. The eccentric, with the gearing, takes care of all addition or carrying from a lower to a higher decimal denomination, while the different ratchet-wheels take care of the additions due to the direct operation of their individual keys.

Having thus fully described my invention, what I claim therein as new, and desire to secure by Letters Patent, is—

1. A registering gear-wheel provided with teeth on its inner circumference in combination with a gear-wheel furnished with teeth on its outer circumference meshing into and driving the said registering gear-wheel, the inner gear-wheel being furnished with a pin v' , a ratchet-wheel provided with a slot v to receive the pin v' the ratchet-wheel K, and an eccentric located on the hub thereof, substantially as and for the purpose described.

2. A registering-wheel provided with teeth on its inner circumference, in combination with a gear-wheel provided with teeth on its outer circumference meshing into and driving the said registering gear-wheel, the inner gear-wheel being furnished with a pin v' , a ratchet-wheel provided with a slot v , to receive pin v' , the ratchet-wheel K, and an eccentric located on the hub thereof, substantially as described.

3. In combination with a registering gear-wheel provided with teeth on its inner circumference, a gear-wheel furnished with teeth on its outer circumference meshing into and driving the said registering gear-wheel, a ratchet-wheel and an eccentric intermediate between the last-named gear-wheel and the ratchet-wheel, said eccentric being rigidly connected with said ratchet-wheel so that it turns with it a predetermined distance substantially as described.

4. The combination of a registering gear-wheel furnished with teeth on its inner circumference, a gear-wheel furnished with teeth on its outer circumference meshing into and driving the said registering-wheel and a ratchet-wheel having an eccentric formed on its hub, substantially as described.

5. The combination of a series of registering gear-wheels furnished with teeth on their inner circumferences, a series of gear-wheels furnished with teeth on their outer circumferences meshing into and driving the said registering-wheels, a series of ratchet-wheels connected with said gear-wheels and having eccentrics on their hubs, and a registering-wheel K³ connected with the above-mentioned registering-wheels but independently operable substantially as described.

6. In a cash-register, the combination of a system of registering-wheels as described, and ratchet-wheels, with a system of press-buttons and intermediate mechanisms between the two systems whereby a sudden pressure on the button will rotate the registering-wheels a certain and positive distance, and said wheels, will be positively retained substantially as and for the purpose specified.

7. In a cash-register the combination of a system of registering-wheels and ratchet-wheels located on the same shaft, said registering-wheels being provided with teeth on their inner circumferences, connections between said registering-wheels comprising externally-toothed wheels and eccentrics, a system of press-buttons and mechanism between the two systems substantially as described.

8. In a cash-register, registering and indicating devices rows of press-buttons arranged in decimal divisions, a system of levers connected with each row of press-buttons, each system including the bifurcated lever C and the lever F located between the forks of the lever C, and mechanism connecting said levers with the registering and indicating devices substantially as described.

9. In a cash-register, the combination of the press-buttons, with the levers C, F, and E, said buttons being made wedge shape at the lower end of their stems, and the levers provided with notches to receive the same substantially as described.

10. In a cash-register, the combination of the press-buttons with the levers C, F, and E, said buttons being made wedge shape at the lower end of their stems and the levers provided with notches to receive the same, the lower or wedge-shaped ends being constructed separately and pivoted to the stem, substantially as and for the purpose described.

11. The combination of the press-buttons, the registering devices and connecting mechanism between the same, said mechanism comprising the levers E, C, and F, rod L, arm R, pawl I, ratchet K, and springs H and t , substantially as described.

12. The combination of the registering device including ratchet-wheels, the press-buttons and intermediate mechanism, said mechanism including the levers C, F, actuated by the press-buttons, rod L pivotally connected to lever F, the pawl I pivoted to the rod L, the arm R connecting the shaft of the ratchet-wheel to the rod L, the spring H pressing against the pawl I, the spring-pawl t and the

lever E suspended from the lever C substantially as described.

5 13. The combination of the registering devices, the press-buttons, the levers C and F and connections therefrom to the registering devices consisting of the rod L, pivoted to lever F, the lever E suspended from the lever C and pivoted on shaft N, the lever P, pivoted on shaft N and the spring *y*, substantially as described.

10 14. The combination of the registering devices, the press-buttons, the levers C and F and connections therefrom to the registering devices comprising the rod L, pivoted to the lever F, the pawl I and ratchet K, the lever E, suspended from the lever C and pivoted on the shaft N, said lever E having a projection *q*, the lever P also pivoted on the shaft

N, spring *y*, adjustable piece *a*, and the drawer A substantially as described.

15. The combination of the lever E, its suspending-link *d*, the lever C, connected to the lever E by said link, the independent press-button O, the lever P and drawer A substantially as described.

16. The combination of the shaft Q, the ratchet-wheel on said shaft the arm R pivoted on said shaft, the pawl I connected to said arm, the spring H pressing against the pawl and the adjustable set-screw S for limiting the forward movement of the pawl substantially as described.

WILLARD POPE PARSONS.

Witnesses:

EDGERTON PARSONS,
ISAAC A. ALLEN.