

No. 646,599.

Patented Apr. 3, 1900.

G. W. CHAPIN.
ADDING MACHINE.

(Application filed Nov. 14, 1899.)

(No Model.)

2 Sheets—Sheet 2.

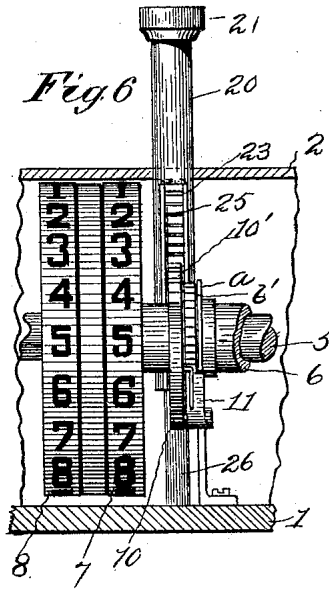
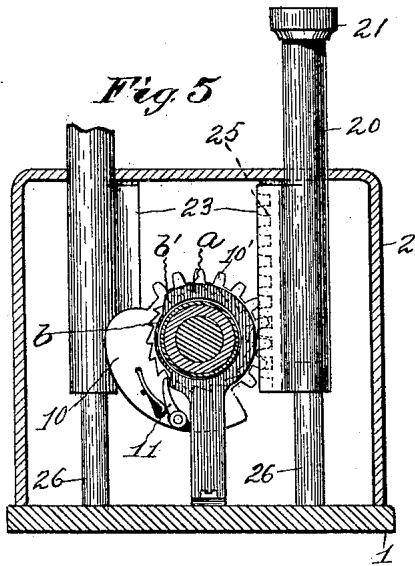
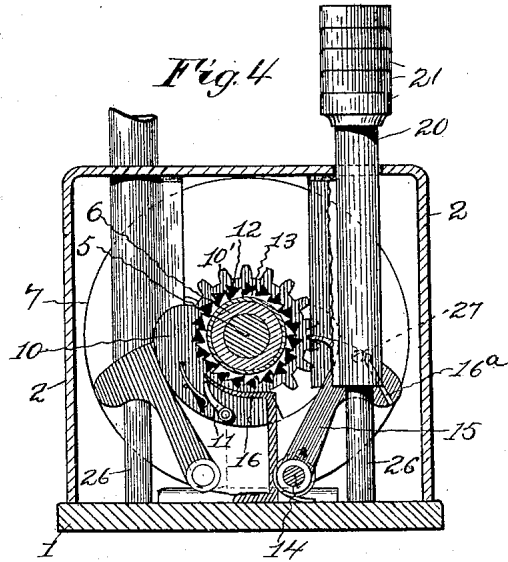
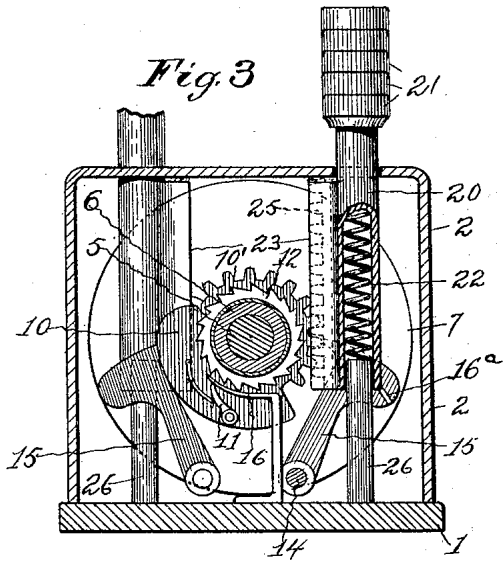

Witnesses:
W. H. Barker.
Luitgard Mola

Inventor:
Gilbert W. Chapin
By W. E. Simonds
Att.

UNITED STATES PATENT OFFICE.

GILBERT W. CHAPIN, OF HARTFORD, CONNECTICUT.

ADDING-MACHINE.

SPECIFICATION forming part of Letters Patent No. 646,599, dated April 3, 1900.

Application filed November 14, 1899, Serial No. 736,913. (No model.)

To all whom it may concern:

Be it known that I, GILBERT W. CHAPIN, of Hartford, county of Hartford, and State of Connecticut, have invented certain new and useful Improvements in Adding-Machines, of which the following is a full, clear, and exact description, whereby any one skilled in the art might make and use the same.

My invention relates to the class of devices commonly known in the art as "computing-machines"—that is, devices having a series of registering-dials so arranged with relation to a keyboard bearing suitable characters that upon the movement of the keys by the operator the dials are so moved as to bring into view characters which record and show at a glance the several steps of a mathematical calculation. For instance, applied to an adding-machine, as herein shown, if the keys bearing the characters "2" and "3" are depressed the registering-dials would instantly show the figure "5."

In many of the devices of the prior art the mechanism for transmitting the proper movements from the keys of the keyboard to the registering-dials is so complicated and so sensitive that in ordinary usage the machines soon become inaccurate, the registering-dials moving too far or too little to bring the character into proper position.

The object of my invention is to produce a device of this class in which many of the objectionable features tending to inaccuracy are eliminated, at the same time providing a machine simple in construction and operation and one which will operate positively, rapidly, and accurately; further, to provide mechanism by which the registering-dials will always be brought to a fixed and positive stop, allowing a substantially-uniform amount of depression to each of the several keys of the keyboard.

To this end my invention consists in the device as a whole, in the details of the several parts, and in the combination of the parts, as hereinafter described, and more particularly set out in the claims.

Referring to the drawings, Figure 1 is a plan view of my improved adding-machine. Fig. 2 is a view in front elevation of the operating parts, the case being cut in section.

Fig. 3 is a cross-sectional view showing more particularly one of the drivers and appurtenant parts. Fig. 4 is a cross-sectional view showing one of the keys and its stop motion for preventing excessive movement of the register-dials. Fig. 5 is a like view showing a modified form of this device. Fig. 6 is a view in side elevation of the parts shown in Fig. 5.

In the accompanying drawings the numeral 1 denotes the base of the machine, and 2 a cover or casing so formed as to completely inclose the operative parts of the machine, protecting them from dust or injury. Mounted upon the base in suitable supports, as 3 4, is the main shaft 5. This shaft has mounted upon it at one end the several dials of a registering device, (denoted by 7 8 9.) As my improvement does not pertain to the register and as any of many forms of rotary registers may be used with my improvement, all of which are well known in the art, a further description of this part of the machine is unnecessary. A sleeve 6 is also mounted upon the shaft 5 and is operatively connected at one end to the first of the series of register-dials 7, so that upon the movement of the sleeve, which is an intermittent or step-by-step movement always in the same direction, the dial 7 will be moved forward, bringing its characters successively into view. As is readily understood, after the dial 7 has moved forward a certain number of steps the second dial 8 will be picked up and moved for one space with the dial 7, and in like manner when the dial 8 has been moved through its series of steps the dial 9 will be caught and moved forward a space. This sleeve 6 (which may well be called the "driving-sleeve") has mounted upon it at intervals corresponding to the distance between the center of the keys drivers 10. These drivers are loosely mounted upon the driving-sleeve 6 and are provided with toothed portions 10', adapted to engage and mesh with the rack-bars 25 of the depression-keys 20, by which they are rotated when the key is reciprocated.

The depression-keys 20, provided with finger-pieces 21, are for convenience tubular in form and project through openings in the case 2, which forms a guide holding them

against lateral movement. Rods 26, secured to the base 1, extend within the lower ends of the tubular depression-keys, and while serving as guides for the keys also form abutments against which one end of the springs 22 rest. These springs hold the keys normally in their uppermost position and are each of sufficient strength to always return the key to its position after it has been depressed.

The rack-bars 25, which mesh with the teeth of the drivers 10, are let into a recess in the projecting portion 23 on the face of the depression-keys, the walls of these recesses forming a guide which, cooperating with the sides of the toothed portion of the drivers, prevents the displacement of the depression-keys.

As already stated, the drivers 10 are loosely mounted on the driving-sleeve 6; but each is provided with one member of a clutch mechanism (in the present case a spring-pressed pawl 11) by which during the movement of the driver in one direction it is locked to the driving-sleeve 6 through the medium of a second clutch member 12, fast on the sleeve and always moving with it as it is revolved. On the reverse movement of the drivers the pawls 11 click idly over the ratchet-teeth of the clutch members 12. It is obvious that as a key is depressed its rack-bar, which is in engagement with the toothed portion of the driver, will move the latter forward, and as the clutch members are engaged the driving-sleeve 6 will be rotated, carrying with it the register-dial 7. As the key is depressed against the pressure of the spring 22, as soon as the pressure of the finger is removed from the key the latter will be returned to its normal position, reversing as it does so the movement of the driver. To prevent too great a movement of the driving-sleeve and to insure a precise movement of the register-dial, stops 13 are arranged on the driving-sleeve in wheel form, one for each depression-key. These wheels are arranged about the driving-sleeve, and their stops are so spaced that upon the depression of a key the driving-sleeve and register-dial will be moved forward a distance equal to the space between two stops. This distance is made exactly the distance which it is necessary for the driving-shaft and register-dial to move to bring the character corresponding to the key into proper position.

At the side of each key and mounted on a bar 14 are spring-actuated stop-levers 15. Pins 27 on the depression-keys 20 are arranged to stand beneath and engage cams 16^a on the side of these stop-levers 15, and these pins move away from the cams when the keys are depressed, but in their upward movement withdraw the stop-levers from engagement with the stop-wheels 13, said levers being meanwhile moved inward. It will be readily seen from this construction that as soon as a key-lever is depressed its driver will move forward, carrying with it the driven clutch member 12 and the driving-sleeve 6. This move-

ment of the driving-sleeve will move the stop-wheel forward, and as the key is depressed still farther the stop-lever 15 will move forward under the impulse of its spring and lie in the path of movement of the next stop, thus permitting only a certain predetermined movement of the driving-sleeve and register-dial.

It is desirable in this class of devices that the amount of depression required to operate the several keys be substantially equal. To equalize as nearly as practical the movement of the several keys and at the same time provide a positive and continuous connection between the keys and the drivers, the clutch members 11 are so arranged that they do not engage the driven clutch members 12 until the keys have been partially depressed. As shown in Fig. 3, a curved guard in the shape of a deflector 16 lies in the path of movement of the clutch member 11, and as the latter is moved backward it is pressed out of engagement with the clutch member 12 and slides along the outer surface of the guard. The amount of this lost motion between the clutch members is varied, according as the keys are of the lower or higher order of figures, it being apparent that the figure "3" key would require less lost motion than the figure "1" key.

In Figs. 5 and 6 a modified form of the device is shown. The arrangement and operation of the drivers and operating-keys are the same as those previously described. In this form, however, a curved guard in the shape of a disk *a* is mounted close to but not interfering with the movement of the driven clutch members. This guard is a trifle larger in diameter than the outside diameter of the clutch members 12. The driving clutch member 11 is made of sufficient width to overlie the edge of the guard *a* and is thus held out of engagement with the clutch member 12 except for such time as it is desired to move the driving-sleeve and its register-dial. As shown in Fig. 5, a small portion of the disk *a* is cut away, as at *b*, thus exposing the clutch member 12 to the action of the driving clutch member 11 only until the latter reaches the point *b'*, when it is thrown out of engagement and becomes inactive.

While I have shown and described a ratchet-and-pawl construction of clutch, it is obvious that other forms of clutch mechanism and stops might be used, and I do not desire to limit myself to the precise construction shown, as other means might be used and come within the scope of my invention.

What I claim as my invention, and desire to secure by Letters Patent, is—

1. In combination in a calculating device, a supporting-rod bearing a register and driving-sleeve for operating the register, a series of driving members loosely mounted on the driving-sleeve each bearing one member of a clutch mechanism, depression-keys in positive and continuous engagement with the

driving members, driven clutch members fast on the driving-sleeve and arranged to be engaged by the driving clutch members in their forward movement, and a curved guard holding the driving clutch member out of engagement with the driven clutch member during the first part of the rotation of the driving members, all substantially as described and for the purposes set forth.

2. In combination in a calculating device, a supporting-rod, bearing a register and driving-sleeve operatively connected with the register, a series of depression-keys, a series of driving clutch members in positive engagement with the depression-keys, a series of driven clutch members adapted to be engaged and move the driving-sleeve and register during the forward movement of the driving clutch members, and a stop mechanism normally disengaged from but arranged to check the movement of the driving-sleeve and register at fixed and predetermined points, all substantially as described and for the purposes set forth.

3. In combination, in a calculating device having a supporting-shaft bearing a register and operating mechanism therefor, a series of depression-keys, a driving-sleeve, mechanism whereby the driving-sleeve and register are adapted to be moved forward upon the depression of a key, a system of stops arranged about the driving-sleeve, and a stop-lever normally out of engagement with the stops but adapted to be thrown into and lie in the path of movement of said stops upon the depression of a key, all substantially as described and for the purposes set forth.

4. In combination in a calculating-machine a register and register-driving mechanism, mounted in operative relation to each other, a series of depression-keys, a series of driving members positively connected with the depression-keys each provided with a driving clutch member, a series of driven clutch members, and means whereby the driving clutch member engages the driven clutch member only during a part of its movement, all substantially as described and for the purposes set forth.

5. In combination in a calculating device, a register and register-driving sleeve mounted in operative relation to each other, a series of depression-keys, a series of clutch mechanisms through the medium of which the depression-keys move the driving-sleeve during their downward movement, and means for engaging and disengaging the clutch mechanism between fixed and predetermined points in the movement of the keys, all substantially as described and for the purposes set forth.

6. In combination, in a calculating device having a supporting-shaft bearing a register and operating mechanism therefor, a series of depression-keys, a driving-sleeve, mechanism whereby the driving-sleeve and register are adapted to be moved forward upon the depression of a key, a system of stops arranged about the driving-sleeve, a stop-lever normally out of engagement with the stops and having a cam, a pin on the depression-key standing below said cam and engaging it on the upward movement of the key to retract the stop-lever, and a spring opposing the movement caused by the pin and cam whereby the stop-lever is adapted to be thrown into and lie in the path of movement of said stops upon the depression of a key, all substantially as described and for the purposes set forth.

7. In combination in a calculating-machine, a register and register-driving mechanism mounted in operative relation to each other, a series of depression-keys, a series of driving members positively connected with the depression-keys each provided with a driving clutch member, a series of driven clutch members, and a series of disks standing in the path of the driving clutch members and cut away at certain points whereby the driving clutch member is permitted to engage the driven clutch member only during a part of its movement, all substantially as described and for the purposes set forth.

GILBERT W. CHAPIN.

Witnesses:

W. E. SIMOND,
LUITGARD MORBA.