

No. 657,266.

Patented Sept. 4, 1900.

A. S. DENNIS.

TYPOGRAPHICAL ADDING MACHINE.

(Application filed Dec. 7, 1895. Renewed Mar. 31, 1898.)

(No Model.)

6 Sheets—Sheet 1.

Fig. 1.

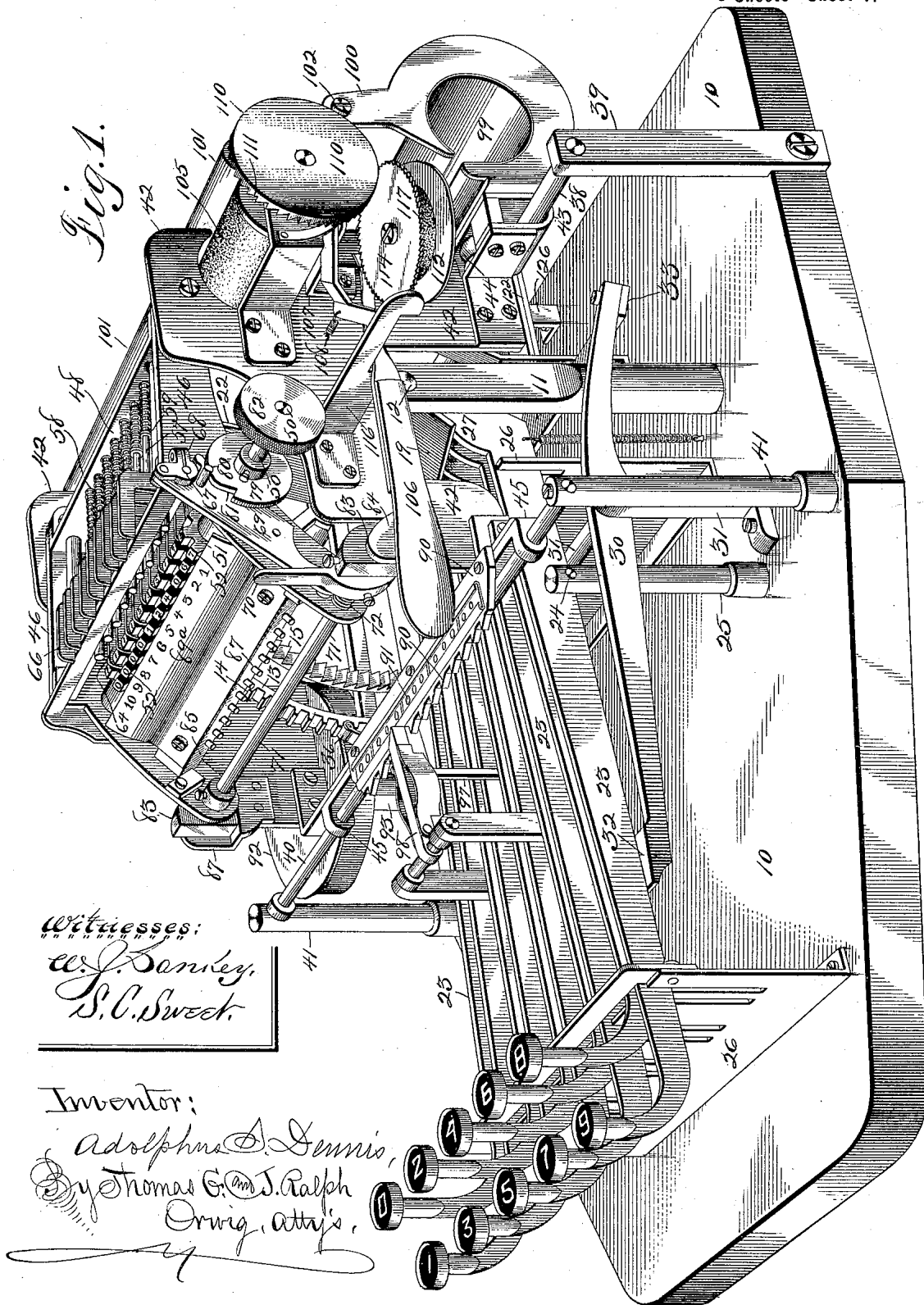

Witnesses:

W. J. Sankey,
S. C. Sweet.

Inventor:

Adolphus S. Dennis,
By Thomas G. & J. Ralph
Orwig, attys.

A. S. DENNIS.

TYPOGRAPHICAL ADDING MACHINE.

(Application filed Dec. 7, 1895. Renewed Mar. 31, 1898.)

(No Model.)

6 Sheets—Sheet 2.

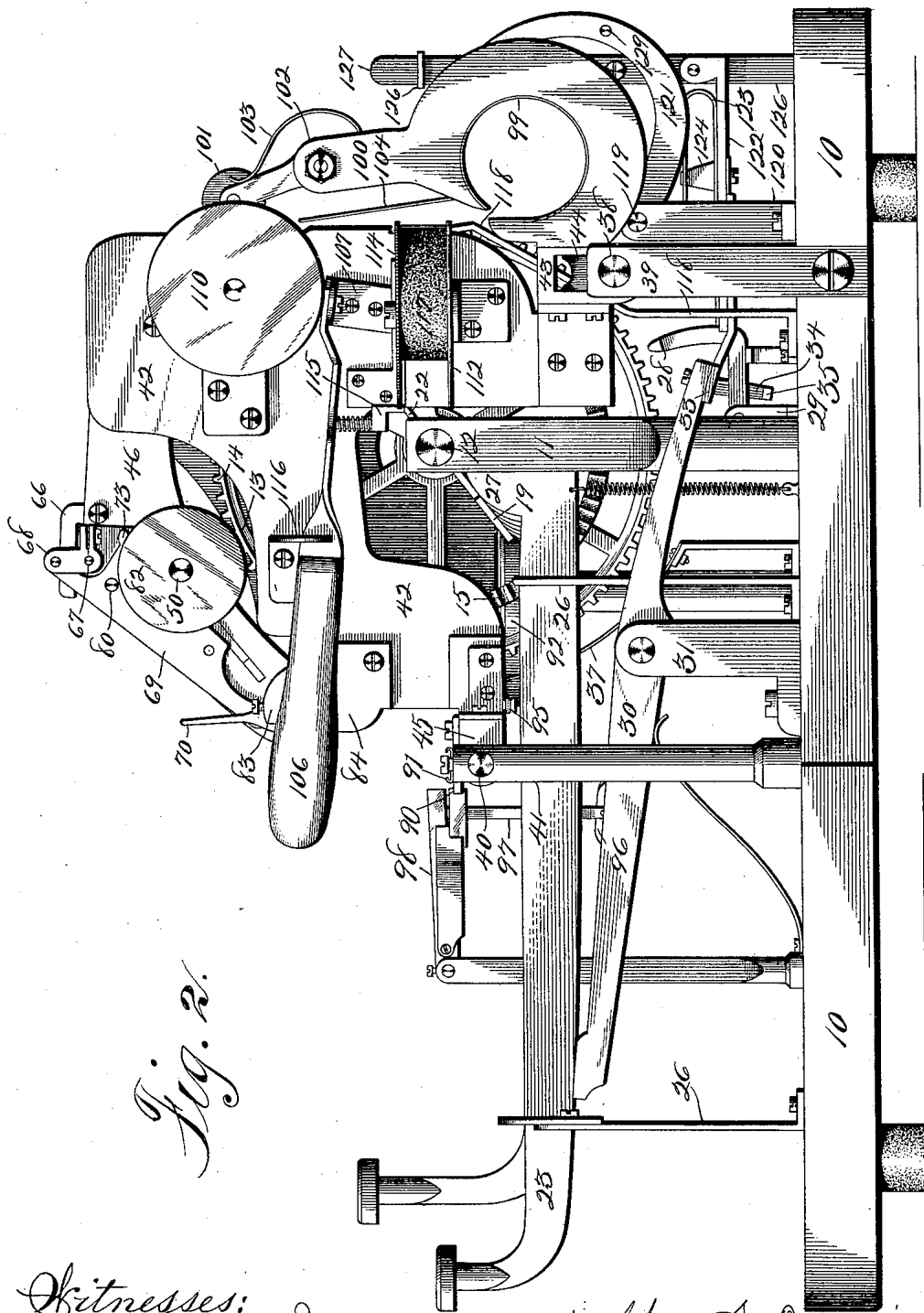

Fig. 2.

Witnesses:
W. J. Sankey,
R. G. Orwig,

Inventor: *Adolphus S. Dennis,*
 By *Thomas G. and J. Ralph Orwig, Attys.*

A. S. DENNIS.

TYPOGRAPHICAL ADDING MACHINE.

(Application filed Dec. 7, 1895. Renewed Mar. 31, 1898.)

(No Model.)

6 Sheets—Sheet 3.

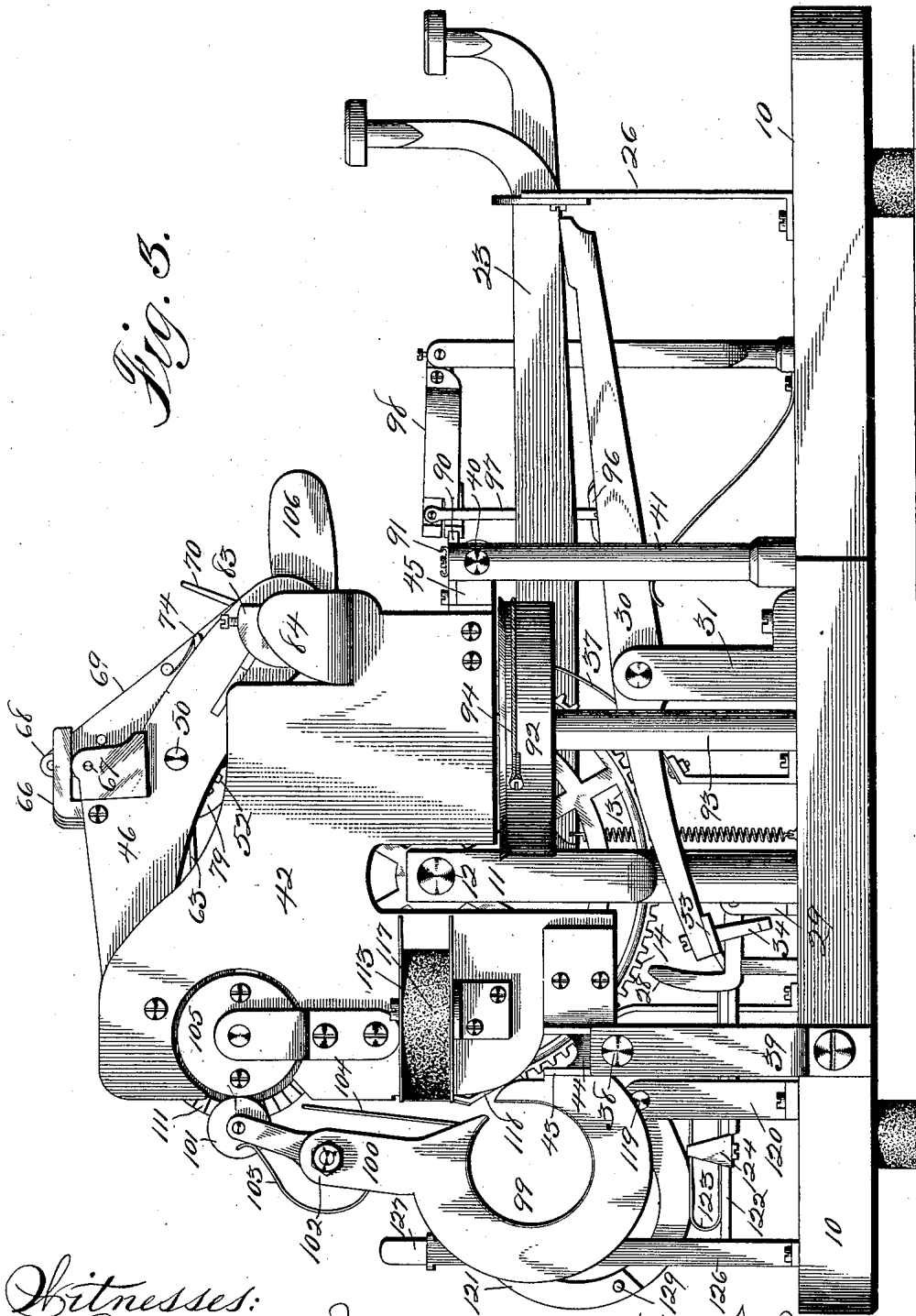

Fig. 3.

Witnesses:
W. J. Sankey,
R. G. Orwig.

Inventor: *Adolphus S. Dennis,*
 By *Thomas G. and J. Ralph Orwig, Attys.*

No. 657,266.

Patented Sept. 4, 1900.

A. S. DENNIS.

TYPOGRAPHICAL ADDING MACHINE.

(Application filed Dec. 7, 1895. Renewed Mar. 31, 1898.)

(No Model.)

6 Sheets—Sheet 4.

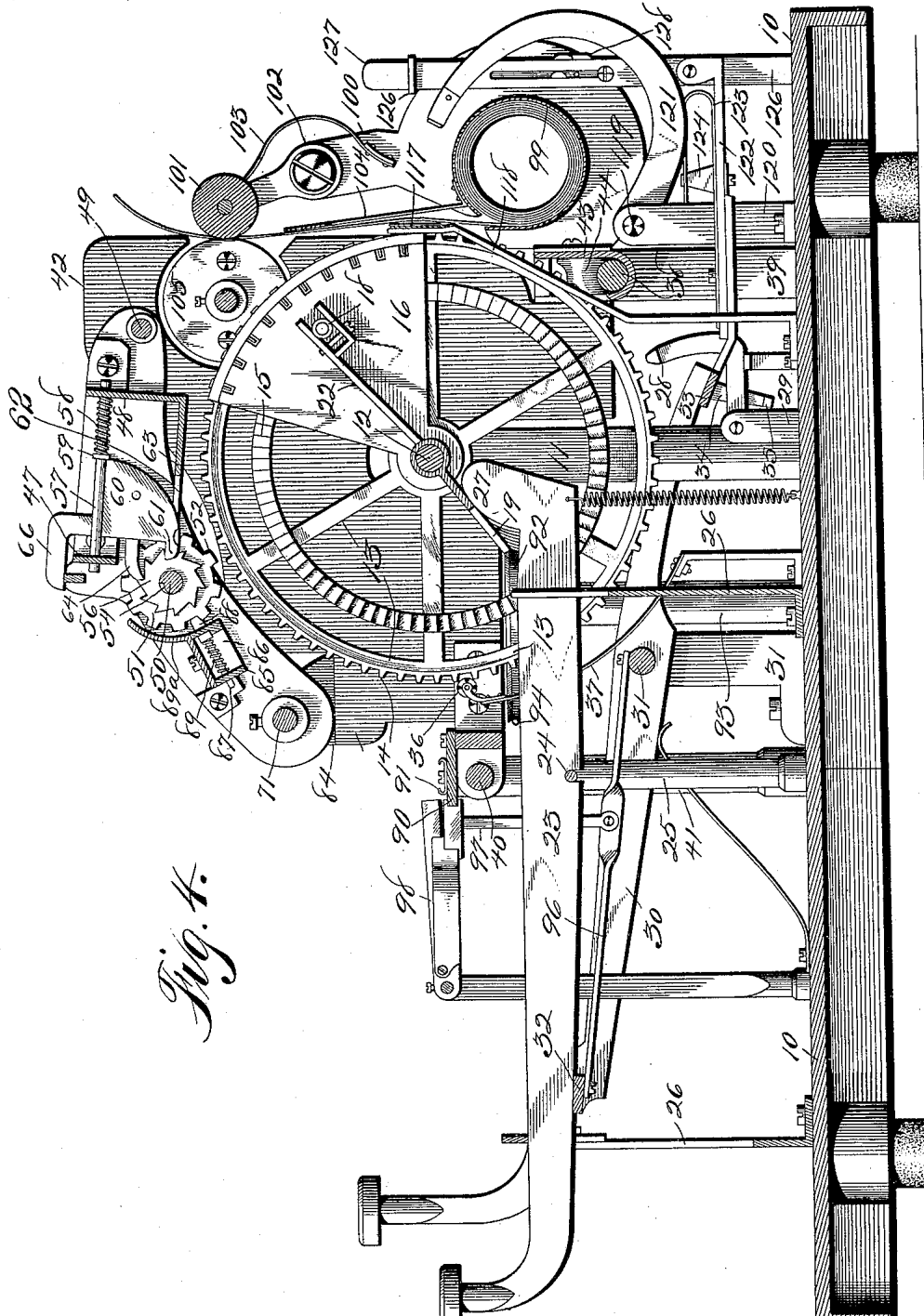

Fig. 4.

Witnesses:
 W. J. Sawyer,
 R. J. Orwig

Inventor: Adolphus S. Dennis,
 By Thomas G. Orwig, Atty.

A. S. DENNIS.

TYPOGRAPHICAL ADDING MACHINE.

(Application filed Dec. 7, 1895. Renewed Mar. 31, 1898.)

(No Model.)

6 Sheets—Sheet 5.

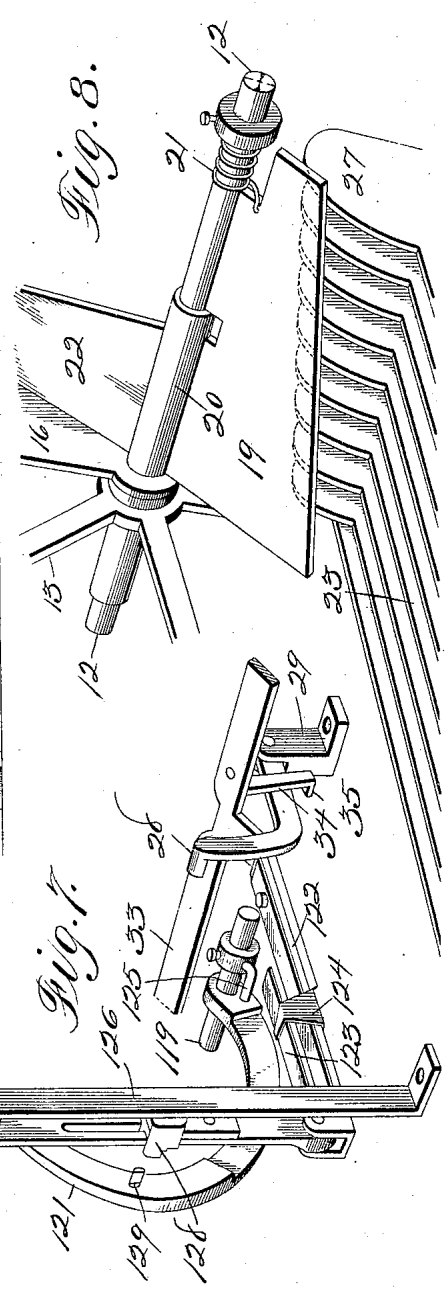
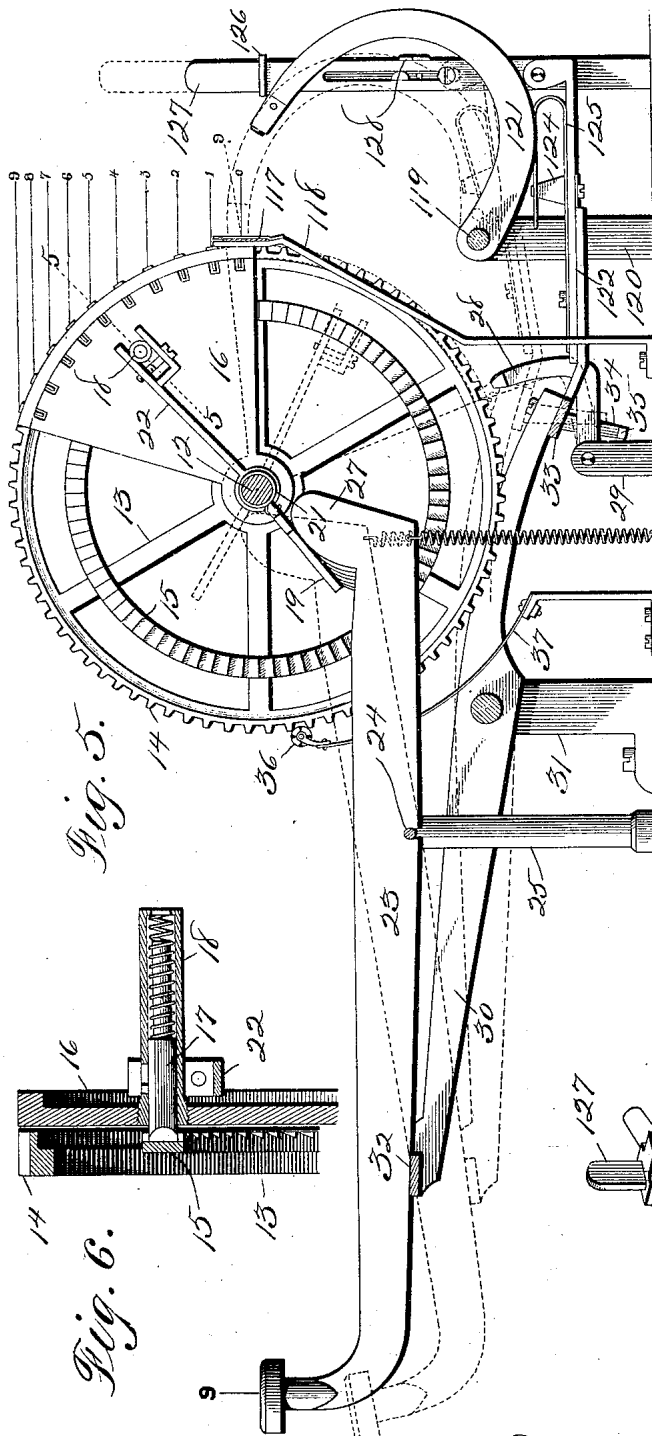

Witnesses:
 W. J. Sankey,
 R. J. Orwig,

Inventor: Adolphus S. Dennis,
 By Thomas G. and J. Ralph Orwig, Attorneys.

No. 657,266.

Patented Sept. 4, 1900.

A. S. DENNIS.

TYPOGRAPHICAL ADDING MACHINE.

(Application filed Dec. 7, 1895. Renewed Mar. 31, 1898.)

(No Model.)

6 Sheets—Sheet 6.

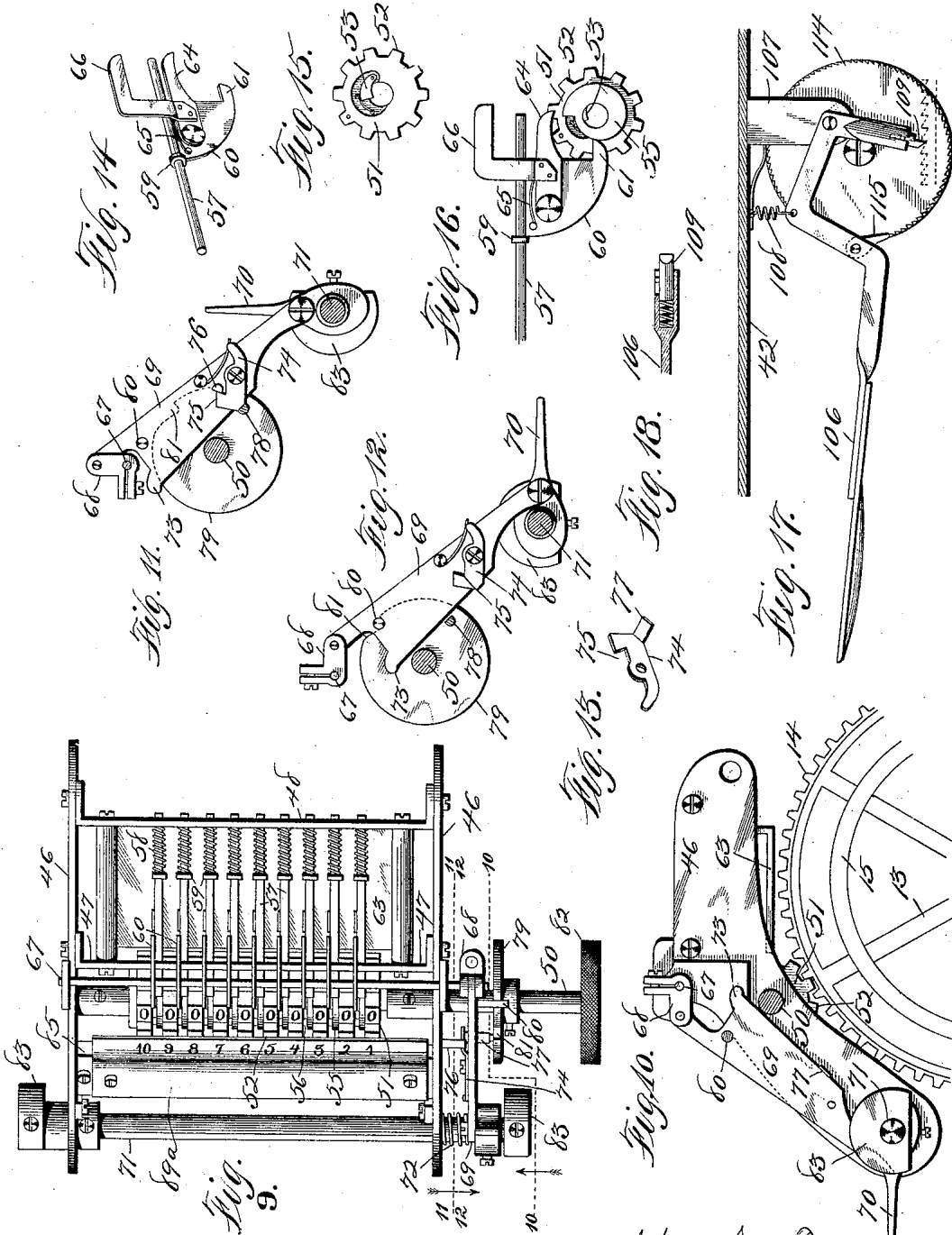

Witnesses:
 W. J. Sansley,
 R. G. Orwig.

Inventor: Adolphus S. Dennis,
 By Thomas C. and J. Ralph Orwig, Attys.

UNITED STATES PATENT OFFICE.

ADOLPHUS S. DENNIS, OF DES MOINES, IOWA, ASSIGNOR TO THE BANKERS
ADDING AND RECORDING MACHINE COMPANY, OF CLEVELAND, OHIO.

TYPOGRAPHICAL ADDING-MACHINE.

SPECIFICATION forming part of Letters Patent No. 657,266, dated September 4, 1900.

Application filed December 7, 1895. Renewed March 31, 1898. Serial No. 676,006. (No model.)

To all whom it may concern:

Be it known that I, ADOLPHUS S. DENNIS, a citizen of the United States of America, residing at Des Moines, in the county of Polk and State of Iowa, have invented a new and useful Typographical Adding-Machine, of which the following is a specification.

My invention relates to that class of typographical adding-machines that employ one adding-wheel and a number of totalizing-wheels mounted in a sliding carriage and adapted to be engaged successively and operated by the adding-wheel.

My object is, first, to provide an adding-machine of simple, cheap, strong, and durable construction.

A further object is to provide in machines of this class having a series of totalizing-wheels improved means for carrying the tens to the adjoining wheel to the left, for returning all of the wheels simultaneously to zero, and for elevating the wheels out of contact with the adding-wheels, so that printing may be carried on without the adding.

My object is, further, to provide improved and simplified paper and ribbon advancing mechanism to be operated by a return of the carriage.

My invention consists in certain combinations of elements and details of construction by which the objects contemplated are attained, as hereinafter set forth, pointed out in my claims, and illustrated in the accompanying drawings, in which—

Figure 1 shows the complete machine in perspective, taken from a point located between the front and right-hand side. Fig. 2 shows the complete machine as seen from the right-hand side thereof. Fig. 3 shows the reverse side of the machine. Fig. 4 is a vertical longitudinal section of the same to show the general arrangement and manner of combination of the parts. Fig. 5 is a side elevation showing in detail the mechanism for operating the type-bearing segment to bring the proper type into the path of the printing-hammer upon a depression of a key, for advancing the adding-gear a distance in proportion to the value of the number on the key depressed, and for operating the printing-ham-

mer, and also illustrating by dotted lines the movements of said parts upon a depression of a key. Fig. 6 is a section through the line 5 5 of Fig. 5, illustrative of the connection between the type-bearing segment and adding-wheel. Fig. 7 is a perspective detail of the printing-hammer and its actuating mechanism. Fig. 8 is a perspective detail illustrative of the mechanism for advancing the type-bearing segment and adding-wheel a distance corresponding to the value of the number on the key depressed. Fig. 9 shows a top view of the carriage bearing the totalizing-wheels. Fig. 10 is a section taken through the indicated line 10 10 of Fig. 9, showing the position of the adding-wheel relative to the totalizing-wheels. Figs. 11 and 12 are sections taken through the line 11 11 and 12 12 of Fig. 9, illustrative of the two positions of the mechanism for returning the totalizing-wheels to zero. Fig. 13 is a perspective of one of the spring-actuated detents of the said mechanism. Fig. 14 shows in perspective one of the devices for controlling the movement of the totalizing-wheels. Fig. 15 shows one of the totalizing-wheels detached. Fig. 16 shows one of the devices for controlling the movement of the totalizing-wheels and also one of said wheels in their relative positions. Fig. 17 is a detail obtained by looking downwardly upon the mechanism for advancing the paper and inking-ribbon synchronously. Fig. 18 is a sectional detail of the pawl for advancing the paper-holding roll.

I shall first describe in detail the means whereby upon the depression of a key the adding-wheel is advanced a distance proportionate to the value of the number marked upon the key and also a type corresponding to the number on the depressed key brought into the path of the printing-hammer.

In the accompanying drawings the referencenumeral 10 is used to indicate the base, and 11 two standards mounted on opposite sides of the base to support an axle 12, and upon this axle the adding-wheel 13 is rotatably mounted. The adding-wheel is provided with cogs 14 on its periphery and an integral ratchet-faced rim 15 on one side. The size of the adding-wheel and the number of cogs

thereon are not essential. However, the cogs 14 and ratchet-teeth 15 must correspond in number.

16 indicates a type-bearing segment rotatably mounted on the axle 12 in close proximity to the adding-wheel, and positioned in the periphery of the segment are a series of types each representing one of the digits. Beginning with zero at the bottom, they are arranged according to their value in regular order on an ascending scale, as indicated in Fig. 5. Mechanism hereinafter described is provided to rotate the segment a distance corresponding to the value of the number marked on the key when said key is depressed, thus bringing the proper type into the path of the printing-hammer. This movement of the segment is caused to advance the adding-wheel, so that the number of cogs thereon that pass a fixed point will equal the value of the number on the key depressed by a spring-actuated detent 17, engaging the ratchet-rim 15, thus carrying the adding-wheel with it when moving downwardly, but not when returning. This detent is mounted in a hollow post 18, fixed to the segment 16, as clearly shown in Fig. 6. The segment is advanced a distance proportionate to the value of the number on the key depressed by means of a plate 19, fixed to a sleeve 20, that is loosely mounted on the axle 12 and held by yielding pressure downwardly through the instrumentality of the spring 21. 22 indicates an arm fixed to the sleeve 20 and extending in the direction of the post 18, to which it is fixed. Hence when the plate 19 is elevated the segment is rotated a distance determined by the elevation of the plate.

The numeral 23 indicates the key-levers, pivoted on a rod 24, that in turn is supported upon the standards 25. Slotted upright plates 26 are fixed to the base 10 and receive the end portions of the key-levers, holding them in vertical alinement and as the slots are of the same length giving an equality of movement to the levers. On the inner end of each lever is a cam-shaped upturned end 27, normally in engagement with the plate 19. The distance to which the cam-shaped end of the lever is removed from the axle 12 determines the movement of the segment upon the depression of a key, inasmuch as the stroke or movement of each lever is the same. Therefore I have arranged them at such distances from the axle 12 that a depression of the key numbered 1 will move the segment and adding-wheel a distance equal to the space from the center of one cog-tooth to the center of the adjoining one and that a depression of key No. 3 will cause the adding-wheel to travel through an arc corresponding to three cogs, and thus throughout the entire number of keys. Key No. 1 is removed a considerable distance from the axle 12, while key No. 9 is quite close thereto. This is all shown clearly in Fig. 8. In this figure also it is shown that only nine key-le-

vers are provided with cam-shaped ends that engage said plate. The tenth, on which the digit cipher is marked, is intended only for printing purposes, and therefore does not engage nor actuate the plate 19. The type O is normally in the path of the printing-hammer. It is therefore not necessary to move the segment when it is desired to print this digit.

To hold the adding-wheel in position and to prevent it from moving farther than in proportion to the value of the key depressed, I have provided a gravity-pawl 28, mounted in a support 29, in position to be brought into engagement with the cogs on the adding-wheel. 30 indicates two levers mounted on suitable supports 31 at the sides of the machine, and 32 and 33 indicate cross-pieces connecting the ends of the levers. The cross-piece 32 is directly beneath the outer ends of the type-levers, so that upon a depression of any key said cross-piece will be pressed downwardly and the part 33 elevated. Fixed to this cross-piece 33 is an arm 34, having its lower end bent at right angles at 35. This arm is so proportioned that as the key-lever approaches the limit of its movement the part 35 will engage the pawl 28 and force it into contact with the adding-wheel. By reason of the connection of the adding-wheel and type-bearing segments the latter are also held stationary and the proper type held in position in the path of the printing-hammer and perfect alinement secured.

36 indicates a roller yieldingly held in contact with the periphery of the adding-wheel by means of the leaf-spring 37. It serves to apply a slight friction to the wheel and also to compel the wheel to stop in a position where the roller is located centrally between two of the teeth, the purpose of which will be hereinafter explained.

The totalizing-wheels, the paper-holding mechanism, and certain other devices are contained on a sliding carriage having a movement transversely of the machine. This carriage is mounted upon a track 38, round in transverse section and fixedly mounted the standards 39, located near the rear end of the base, and a rod 40, supported in a like manner on the posts 41 near the forward end of the base. The carriage-frame comprises two side pieces 42, irregular in shape and connected by means of an approximately U-shaped cross-piece 43, passed beneath the track 38 and having concave-surfaced rollers 44 mounted therein and resting upon the track to thereby support the weight of the carriage. At its forward end the carriage is provided with two arms 45, having openings in their outer ends to admit the rod 40 and provide a support for the forward end of the carriage. Upon this carriage a frame is mounted, which contains a number of totalizing-wheels designed to be successively brought into gear with the adding-wheel to record the aggregate of the movements made by said

adding-wheel. The description of this mechanism will be made clearer by referring to Fig. 9 and its accompanying details.

The frame for supporting the totalizing-wheels and accompanying parts comprises two parallel side pieces 46 and two cross-braces 47 and 48. The side pieces are pivoted at their rear ends to a rod 49, that is rigidly mounted in the side pieces of the carriage-frame, thus permitting the frame of the totalizing-wheels to swing in a vertical plane.

50 indicates a shaft rotatably mounted in the side pieces 46 near the central portion thereof. The totalizing-wheels 51 are loosely mounted on this shaft. In number they correspond to the number of columns into which it is desired to carry the addition capacity of the machine. In the present instance ten are shown. Each cog-wheel has ten peripheral cogs 52 of a size designed to mesh with the cogs of the adding-wheel, each cog having marked thereon one of the ten digits, and each wheel is also provided with an internal spring-actuated detent 53 to engage a notch 54, that extends longitudinally of the shaft through all of the totalizing-wheels. Each wheel is also provided with an integral cam 55, having a spiral edge so arranged that an object yieldingly held against said edge will be forced gradually outward from the center of the wheel until a revolution has been described, and on the opposite side of the totalizing-wheel is an integral ratchet-wheel 56, the teeth of which correspond in number with the cogs. It is understood that the totalizing-wheels are advanced by means of the adding-wheel, and it is obvious that they may all be returned simultaneously to a position where the cogs bearing like digits appear to the operator by a backward rotation of the shaft on which they are mounted by reason of the detents 53 engaging the notch 54.

It is necessary in an adding-machine that when one totalizing-wheel has been moved more than one complete revolution the next adjoining wheel to the left be moved one-tenth of a revolution. This I accomplish by the following mechanism: For each set of adjoining cams and ratchets between the totalizing-wheels I have provided a rod 57, having its ends slidingly mounted in the cross-braces 47 and 48 and yieldingly held at the limit of its movement in the direction of the totalizing-wheels by the extensible coil-spring 58, wound upon the rod 57 and engaging a collar 59, fixed thereto, and also the cross-brace 48. On the forward end of each rod is fixed a plate 60, projecting downwardly therefrom and terminating in a forwardly-projecting arm 61, designed to engage one of the cams 55. The plates are held in position by insertion in the slots 62, formed in guide-plate 63, that extends downwardly and forwardly from the cross-brace 48.

64 indicates a pawl pivoted to the side of the plate 60 and normally held in engagement with the ratchet 56, adjacent to the cam 55,

that is engaged by the arm 61. This pawl is normally pressed downwardly by the spring 65. It is obvious that as the totalizing-wheel is rotated the cam 55 will gradually force the arm 61 rearwardly until one complete revolution has been performed, when the spring 58 will force the rod 57 and pawl 64 forwardly sufficiently to advance the ratchet engaged by the pawl the distance of one notch or tooth. Hence a complete revolution of one totalizing-wheel will advance its adjoining wheel to the left one-tenth of a revolution.

66 indicates an arm fixed to the pawl 64 and projecting upwardly and forwardly therefrom. Its function is to provide means whereby the pawl may be thrown out of engagement with the ratchet-wheel. The mechanism whereby this movement may be accomplished with all of the pawls simultaneously, so that the totalizing-wheels may be returned to the starting-point, comprises a flat bar 67, pivoted eccentrically in the sides 46, directly above the totalizing-wheels. The bar normally lies in a horizontal plane; but when turned on edge it engages the arms 66, and thus elevates the pawls 64 from contact with the ratchets.

68 indicates an arm on the outer end of the bar 67, and 69 a flat connecting-plate pivoted to the clutch at one end and to a cam-shaped lever 70, fixed to a shaft 71, rotatably mounted in the lower ends of the side pieces 46. Thus when the cam-lever is raised the bar 67 will be turned on edge. However, the said lever is normally held to its downward limit by means of a spring 72 on the shaft 71, and this downward limit is determined by an extension 73 on the plate 69, that engages the shaft on which the totalizing-wheels are mounted. Assuming that upon each totalizing-wheel a different number is visible to the operator and that it is desirable to return them, so that the ciphers on each wheel will take the position of said number to thereby prepare the machine for commencing an addition, the said plate 69 is moved to its upward limit and is there held in place against the action of the spring 72 by means of a spring-actuated pawl 74, pivoted to the side of the plate 69 and having a notch 75 in its one end designed to admit a pin 76, that is fixed in one of the sides 46. To trip the plate 69, so that the pawls are again permitted to engage the ratchets of the totalizing-wheels when said wheels are in position for starting an addition, I have provided a lateral extension 77 on the pawl 74, designed to pass under the plate 69 and be engaged by a pin 78, fixed to the side of a disk 79, which in turn is fixed to the shaft of the totalizing-wheels. This pin is so placed on the disk that it will engage the pawl 74 and trip the plate 69. A further rotation of the shaft is prevented by means of a pin 80 on the plate 69 dropping into a notch 81 in the periphery of the disk 79 when the plate 69 is moved downwardly. A thumb-wheel 82 is mounted on the outer

end of the totalizing-wheel shaft to provide for its convenient manual rotation.

In order to turn the totalizing-wheels to a position for starting an addition, it is necessary to elevate them out of gear with the adding-wheel. This is accomplished simultaneously with the withdrawal of the pawls 64 from the ratchets 56 by means of two disks 83, fixed to the opposite ends of the shaft 71 and flattened on the sides that are undermost when the plate 69 is at the downward limit of its movement. These disks rest on the supports 84, which are fixed to the side pieces of the sliding-carriage frame. When the plate 69 is elevated, the forward end of the frame bearing the totalizing-wheels is also elevated, because the disks 83 engage the supports 84 at points farther from their centers.

To prevent the totalizing-wheels from rotating inadvertently or from moving farther than they are impelled by positive movements, I have provided a small frame composed of two parallel side pieces 85 and cross-pieces 86 at their ends. The frame thus formed is fitted between the side pieces 46, adjacent to the totalizing-wheels, and extended parallel with the shaft of said wheels. Within the frame are mounted slidingly a number of rods 87, each having a rounded head 88, designed to enter between the cog-teeth of one of the totalizing-wheels. Springs 89 normally force the rods in the direction of the totalizing-wheels, so that it is only by a positive force sufficient to overcome the pressure of said spring that the totalizing-wheel may be rotated in either direction. A plate 89^a is fixed to the top of this frame and is provided with a straight edge at its top. It serves to cover the totalizing-wheels, so that only one row of digits thereon will be visible to the operator.

It is now understood that the adding-wheel is stationary as to transverse movement and also that the totalizing-wheels are capable of a movement transversely of the machine. Each totalizing-wheel represents a column in the addition. I shall now proceed to describe the mechanism by which the digit on the key depressed is placed in the proper column.

On the front end of the sliding carriage is fixed a rack 90, having a number of teeth corresponding to the number of totalizing-wheels. Immediately above the rack I preferably place a plate 91, having marked thereon a scale by which the columns may be readily distinguished. 92 indicates a spring-actuated drum of common form mounted on an upright 93 at the left-hand side of the machine-frame. This drum has a cord or belt 94 wound thereupon and connected with the sliding-carriage frame at 95 to exert a yielding pressure upon the sliding carriage, tending to move it to the left. As hereinbefore stated, the levers 30 and cross-pieces 32 and 33 at their-ends are operated upon a depression of any key. Attached to this cross-piece

32 and to the axle of the said levers 30 is a bar 96, having pivoted thereto a rod 97, which in turn is attached to a dog 98 of the ordinary form that engages the said rack 90 and when a key is operated permits the rack to move the length of one notch. The parts are so arranged that the position of the dog 98 relative to the rack 90 is identical with the position of the totalizing-wheels relative to the adding-wheels, so that when the dog 98 is placed in the third notch from the right a depression of any key will print and add the digit on the key in the hundreds-column, and as the key is released the carriage will automatically move one notch to the left, so that the digit on the key next depressed will be printed and added on the same line in the tens-column.

The means for holding and advancing the paper comprise a hollow open-ended cylinder 99, slotted longitudinally at its forward top portion and supported fixedly at the rear lower end of the sliding carriage. Two arms 100 are fixed to and project upwardly from the ends of the cylinder to support a roller 101. A hinged elbow is formed in each drum at 102, and leaf-springs 103 serve to normally press the roller forwardly.

104 indicates a guide projecting upwardly from the top of the cylinder to a point near the roller 101.

105 indicates a rubber-faced roller mounted in the sliding-carriage frame in front of and parallel with the roller 101 to be engaged by said roller and clamps the paper between them.

The paper is advanced by the mechanism shown in detail in Figs. 17 and 18. 106 indicates a lever pivoted to move in a horizontal plane to the support 107, fixed to the right side of the sliding-carriage frame. Its handle extends straight forwardly to a point where it may be conveniently grasped by the operator and is held by the yielding pressure of the spring 108, close to the side of the carriage. Its other end is bent at right angles in a horizontal plane and is provided with a spring-actuated pawl 109. 110 indicates a disk fixed to the end of the roller 105 and having a ratchet-rim 111 on its inner face to be engaged by said spring-actuated pawl 109. In Fig. 17 this ratchet-rim is indicated in its proper position by broken lines. It is obvious that a movement of this lever away from the machine will rotate the roller 105, and thus advance the paper from one line to the next.

The inking-ribbon is advanced simultaneously with the rotation of said roller as follows: 112 and 113 are two flanged drums rotatably mounted in a horizontal plane on opposite sides of the sliding-carriage frame. The top flange of drum 112 is provided with ratchet-teeth 114, and 115 indicates a spring-actuated detent attached to the lever 106 and in engagement with the flange 112. As the lever 106 is moved inwardly, the drum is ro-

tated part of a revolution. The movement of the lever is limited by a rigid arm 116, fixed to the frame of the sliding carriage. The lever is first moved to its limit, and then a further pressure thereupon moves the entire carriage laterally. 117 indicates a ribbon wound upon said drums and passed between the paper and the types on the segment 16. It is supported at its central portion on opposite sides of the segment by ribbon-guides 118 of common form.

The following description of the mechanism for actuating the printing-hammer will be made clearer by a close study of Figs. 5 and 7. 119 indicates a rock-shaft supported in the uprights 120 near the rear end of the base. 121 indicates the printing-hammer, fixedly mounted upon said shaft. The hammer is approximately semicircular in shape, and its top end is designed to strike against the type-bearing segment when operated. Motion is imparted to the hammer upon the depression of a key as follows: 122 indicates an arm on the cross-piece 33, that extends rearwardly in an approximately-horizontal plane. 123 indicates a leaf-spring fixed to its top and curved back over the arm. The free end of the spring is held under pressure in a position close to the arm by the clip 124, which is attached to the arm and overlaps the spring. 125 indicates an arm fixed to the rock-shaft adjacent to the hammer and overlapping the free end of the spring. As the arm 122 is raised upon the depression of a key the spring engages said arm 125, and thus forces the hammer upwardly. Power is stored in this spring during the first part of the stroke of the hammer and then suddenly released, when the type-bearing segment is in position to thereby bring the hammer into forcible contact with the segment, as follows: 126 indicates an upright guide fixed to the base adjacent to the hammer and having its top bent to overlap the hammer. 127 indicates a flat bar pivoted to the outer end of the arm 122, with its upper end passed through a slot in the top of the upright 126, and fixed to this bar is a trip device 128 to project laterally in the direction of the hammer. 129 indicates a pin fixed to the hammer to engage said trip device. This trip device and pin are so arranged relative to each other that as the bar bearing the trip is elevated and the hammer moved in the segment of a circle by a depression of a key the path of the pin will intercept the path of the trip device and the hammer be stopped in its movement until the trip device has been elevated sufficiently to pass the pin. During this elevation of the trip device it is obvious that the spring 123 is being depressed, so that when the hammer is released it will be forced with all the pressure of said spring against the paper, thereby pressing the paper and inking-ribbon against the type-bearing segment and making an imprint upon the paper.

Although the construction and function of

each separate part of the machine have been described, it is thought that a clearer idea of its operation as a whole will be obtained by following the movements required to print and add a number of figures. We will assume that the numbers "65" and "126" are to be printed and added and that the machine has been supplied with a sheet of paper and is in operative condition. The operator will first grasp the lever 106 and thereby move the carriage to the right until the dog 98 reaches the notch on the scale 91 indicating the tens-column. The operator then depresses the key bearing the digit "6," and as a result the adding-wheel 13 is moved through an arc of six cogs in length and the second totalizing-wheel moved so that the tooth bearing the digit "6" appears above the plate 89^a. The type-bearing segment is, however, first moved so that the type marked "6" is brought into the path of the hammer and the hammer is operated as set forth to print the digit on the paper. When the pressure upon the key is removed, the parts are all returned to position by spring-pressure and the sliding carriage permitted to move one notch to the left by the dog 98, thus bringing the totalizing-wheel in the units-column into mesh with the adding-wheel and at the same time advancing the paper laterally relative to the type-segment and hammer. The key marked "5" is then struck and the same movements accomplished. The lever 106 is then moved laterally, thus advancing the paper longitudinally the distance of one line and simultaneously advancing the inking-ribbon. The dog 98 is placed in the notch corresponding to the hundreds-column and the keys bearing the numbers "1," "2," and "6" depressed in turn. The movements just described take place upon the depression of each key, except that as the key 6 in the units-column is depressed the first totalizing-wheel is moved far enough to bring the digit "1" thereon above the plate 89^a. Inasmuch as it has been moved thus far in the addition more than a complete revolution the arm 61 has been moved backwardly by the cam 55 until the end of the cam was reached and then forced by spring-pressure forwardly, thus causing the detent 64 to move the ratchet 56 of the next totalizing-wheel one notch, resulting in bringing the digit "9" thereon into position above the plate 89^a. Upon referring to the digits on the totalizing-wheels visible to the operator the number "191" will appear as the result of the addition of the numbers "65" and "126." Upon the paper these numbers will also be printed thus—

65
126

If it is desirable to print the result of the addition beneath the numbers, the operator places the carriage in position so that the dog 98 will enter the notch corresponding to the column of the last figure of the result as it

appears upon the totalizing-wheels, in the present instance in the hundreds-column. The keys corresponding to the result—that is, “1 9 1”—are then struck, and the sum

5 appears upon the paper thus—

65
126
—
191

10 To start a new addition, the cam-lever 70 is elevated, thus throwing the totalizing-wheels out of mesh with the adding-wheel and the detents 64 out of contact with the ratchet-

15 wheels 56. The thumb-wheel 110 is then operated until the cipher is visible to the operator upon each of the totalizing-wheels, when they are automatically stopped, as before described.

20 The subject-matter of invention herein shown and described is likewise present in my application filed March 25, 1898, Serial No. 675,063, in which the broader and more fundamental claims will be found.

25 What I claim as my invention is—

1. The combination in an adding-machine of a single peripherally-cogged adding-wheel, rotatably mounted, a ratchet-rim on one side of the adding-wheel, an arm rotatably mounted

30 on the shaft of the adding-wheel, a spring-actuated detent in the outer end of said arm to engage the ratchet-rim, a series of nine key-levers, and means whereby a depression of any key will advance the adding-wheel a distance corresponding to the value of the number

35 on the key depressed.

2. The combination, in an adding-machine, of an adding-wheel, rotatably mounted, a series of totalizing-wheels designed to be successively brought into engagement therewith,

40 a plate rotatably mounted on the adding-wheel shaft, an arm extending outwardly from said plate, a ratchet device on the arm arranged to engage and rotate said adding-

45 wheel when the plate is moved, and a series of key-levers, arranged to engage said plate at distances from the shaft proportionate to the value of the number marked thereon.

3. The combination, in an adding-machine,

50 of a suitable shaft rotatably mounted and having a longitudinal groove, a series of totalizing-wheels rotatably mounted on said shaft and each having a cam on one side and a ratchet on the other, an internal spring-actuated detent in each totalizing-wheel, a series of arms to engage said cams, yielding pressure devices applied to said arms, a pawl pivoted to each arm to engage the ratchet on the adjoining totalizing-wheel, an arm projecting upwardly and then forwardly from

60 each pawl, a flat bar eccentrically mounted above the totalizing-wheels to engage said arm and when turned on edge to hold the pawls out of engagement with the ratchets, an arm

65 fixed to the bar, a plate pivoted to said arm, a spring-actuated pawl pivoted to the plate, a pin fixed to a stationary support to be en-

gaged by said pawl when the plate is held in position with the bar on edge, a disk fixed to the shaft of the adding-wheels and a pin on said disk to release said pawl from its pin when the totalizing-wheels are returned to starting position and a spring for returning the flat bar to a horizontal position.

4. The combination, in an adding-machine,

75 of a suitable shaft rotatably mounted and having a longitudinal groove, a series of totalizing-wheels rotatably mounted on said shaft and each having a cam on one side and a ratchet on the other, an internal spring-actuated detent in each totalizing-wheel, and a series of arms to engage said cams, yielding pressure devices applied to said arms, a pawl pivoted to each arm to engage the ratchet on the adjoining totalizing-wheel, an arm projecting upwardly and then forwardly from

80 each pawl, a flat bar eccentrically mounted above the totalizing-wheels to engage said arm, and when turned on edge to hold the pawls out of engagement with the ratchets,

85 an arm fixed to the bar a plate pivoted to said arm a spring-actuated pawl pivoted to the plate, a pin fixed to a stationary support to be engaged by said pawl when the plate is held in position with the bar on edge, a disk

90 having a notch in its edge fixed to the shaft of the adding-wheels and a pin on said disk to release said pawl from its pin when the totalizing-wheels are returned to starting position a spring for returning the flat bar to a

95 horizontal position, and a pin on the said plate so positioned as to enter said notch in the disk and prevent its further rotation, when the flat bar is returned to a horizontal position.

5. The combination, in an adding-machine, of a frame pivotally supported at its rear end, a series of totalizing-wheels rotatably mounted therein, a single adding-wheel, means for bringing any one of the totalizing-wheels into

100 mesh with the adding-wheel, means for operating the adding-wheel, a shaft rotatably mounted in the front end of the said frame, one or more cams on said frame, a support for each cam, and a lever whereby the shaft

105 may be rocked to elevate the totalizing-wheels.

6. The combination, in an adding-machine, of a frame pivotally supported at its rear end, a rock-shaft mounted in the forward end of said frame, one or more cams on said shaft,

120 to rest upon a fixed support, means for rocking the shaft, a flat bar eccentrically pivoted on the frame, an arm on one end thereof, a plate for connecting the rock-shaft and said arm, a series of totalizing-wheels rotatably

125 mounted within said frame, and each having a cam on one side and a ratchet on the other, a series of spring-actuated arms to engage said cams, a pawl pivoted to each arm to engage the adjoining ratchet, and an arm fixed

130 to each pawl to overlap said flat bar, substantially as and for the purposes stated.

7. An adding-machine, comprising a suitable base, a series of nine key-levers of differ-

ent lengths pivoted therein, means for equalizing the movements of the levers, a single peripherally-cogged adding-wheel rotatably mounted, a plate pivotally mounted at the side of the adding-wheel to be engaged by the key-levers, an arm fixed to the plate, a ratchet device in said arm to engage and actuate the adding-wheel, a carriage slidingly mounted, a yielding pressure device to move the carriage a rack on said carriage, a dog to engage said rack, means for actuating the dog upon a depression of any key, means for engaging and stopping the rotation of the adding-wheel upon the completion of the movement of any key, a frame pivoted at its rear end to the sliding carriage, a series of totalizing-wheels mounted in the carriage, means for rotating the next wheel to the left when any totalizing-wheel is rotated a complete revolution, means whereby the said frame may be elevated to throw the totalizing-wheels and adding-wheels out of gear and to simultaneously throw said totalizing-wheel-advancing means out of contact with the wheels, means for returning all of the totalizing-wheels to the starting-point, substantially as and for the purposes stated.

8. The combination, in a typographical adding-machine, of a sliding carriage, paper-holding mechanism thereon, a roller mounted on the carriage having a ratchet-faced disk fixed thereto, a second roller, yielding pressure devices for holding the rollers in contact, two ribbon-spools mounted for rotation in a horizontal plane, a ratchet-edged flange on one spool, a lever fulcrumed to the carriage, a spring-actuated pawl in its one end to engage the ratchet-rim on the roller and a spring-actuated pawl to engage the ratchet-edged flange.

9. The combination, in a typographical adding-machine, of a sliding carriage, paper-holding mechanism thereon, a roller mounted on the carriage having a ratchet-faced disk fixed thereto, a second roller, yielding pressure devices for holding the rollers in contact, two ribbon-spools mounted for rotation in a horizontal plane, a ratchet-edged flange on one spool, a lever fulcrumed to the carriage, a spring-actuated pawl in its one end to engage the ratchet-rim on the roller, a spring-actuated pawl to engage the ratchet-edged flange, a guide for limiting the movement of the lever and a spring for returning the lever.

10. In a printing-machine, the combination of a pivoted segmental printing-hammer, an arm adjacent to the hammer, means for elevating the arm, a spring on the arm to engage the hammer when elevated, a vertically-slid-

ing upright on said arm, a trip device on the upright and a pin on the hammer, substantially as and for the purposes stated.

11. A typographical adding-machine, comprising a peripherally-cogged adding-wheel having a ratchet-rim at one side, and rotatably mounted, a type-bearing segment rotatably mounted on the shaft of the adding-wheel, a pawl thereon to engage said ratchet-rim, means for moving the type-bearing segment, a printing-hammer, means for operating the hammer, a sliding carriage, paper-holding mechanism mounted thereon, ribbon-holding mechanism on the carriage, means for advancing the paper and ribbon simultaneously, means for operating the carriage and the totalizing mechanism mounted on the carriage all arranged and combined substantially as and for the purposes stated.

12. The combination in a typographical adding-machine, of an adding-wheel, means for rotating the adding-wheel a distance corresponding to the value of the key depressed, a type-bearing segment pivoted to the same shaft, a ratchet device for moving the segment in unison with the adding-wheel in one direction, a spring for returning the segment and a printing-hammer substantially as and for the purposes stated.

13. The combination in a typographical adding-machine, of an adding-wheel rotatably mounted and having a ratchet-face on one side, a type-bearing segment rotatably mounted on the same shaft, a spring-actuated pawl in said type-bearing segment to engage said ratchet-face on the adding-wheel, means for rotating said segment the proper distance upon the depression of a key, and a suitable printing-hammer substantially as and for the purposes stated.

14. The combination, in an adding-machine, of an adding-wheel rotatably mounted, a series of totalizing-wheels designed to be successively brought into engagement therewith, a series of key-levers pivoted to a common fulcrum each having a number marked thereon and of a length from the pivotal point greater in proportion to the value of said number, means for limiting and equalizing the movement of the levers, a plate rotatably mounted on the axle of the adding-wheel, to be engaged by said key-levers, an arm connected with the plate, and a ratchet device on the arm to engage and actuate the adding-wheel.

ADOLPHUS S. DENNIS.

Witnesses:

J. RALPH ORWIG,
THOMAS G. ORWIG.